

groov EPIC PROCESSOR

Features

- > High-resolution LCD display with touch capability for edge configuration and *groov*® View HMI
- > Web-based commissioning, troubleshooting, and HMI, with built-in security and authentication
- > Pre-loaded software includes *groov* Manage, *groov* View, Node-RED, Ignition Edge®, and CODESYS® Runtime Engine
- > Dual independent Gigabit Ethernet network interfaces
- > Dual USB ports for serial communications, touchscreen monitors, keyboards, or a mouse
- > HDMI port for external monitors or touchscreen
- > OptoSupport Remote Support Service for remote diagnosis and troubleshooting
- > Program with flowcharts and scripting, or IEC 61131-3 compliant languages like ladder diagram, function block diagram, sequential function chart, and structured text
- > UL Hazardous Locations approved and ATEX compliant

DESCRIPTION

The **Edge Programmable Industrial Controller** is an embedded Linux®, real-time controller with gateway functions.

The modern design of the *groov* EPIC processor offers a compact, industrial computer that features a resistive-touch, high-resolution LCD display. The LCD display lifts to provide easy access to the power button, power supply connectors, network interfaces, ports, and status LEDs.

- Dual, independent Gigabit Ethernet network interfaces securely segment trusted networks (like your control network) from untrusted networks (like the Internet).
- Dual USB ports for serial interfaces, WiFi adapters, and keyboard, mouse, and touchscreen controls.
- HDMI port connects to an external monitor for displaying configuration and *groov* View HMI on an external large screen, which is also useful for OEM applications where the EPIC system is built into a machine.

The processor can operate through a wide range of operating temperatures (-20 to 70 °C) and with its industrial design, it can be used in a large variety of applications and operating environments. The CPU is an industrial, quad-core ARM® processor running open-source Linux with real-time extensions.



GRV-EPIC-PR1 processor

Software tools include:

- *groov* Manage for browser-based management of your *groov* EPIC system, from the integrated front touchscreen display or any browser-based device
- *groov* View for building and viewing custom operator interfaces for local, mobile, and browser-based devices
- PAC Project™ Basic Software Suite (installed and running on your Microsoft® Windows® computer) for developing control programs and a Windows-based HMI
- Access to the Linux operating system through a secure shell to run custom applications (requires the free SSH License, GROOV-LIC-SHELL)
- Node-RED for creating data flows to connect cloud services, databases, and APIs through pre-built nodes
- Ignition Edge from Inductive Automation® for connecting to Allen-Bradley®, Siemens®, and Modbus®/TCP devices via OPC UA, and for efficient IIoT communications using MQTT with Sparkplug payload (requires the purchase of GROOV-LIC-EDGE)

Part Numbers

Part	Description
GRV-EPIC-PR1	On-the-rack controller for the <i>groov</i> EPIC system.
GROOV-LIC-EDGE	Activation key for Ignition Edge software.
GROOV-LIC-CRE	Activation key for CODESYS Runtime Engine software.
GROOV-LIC-SHELL	Activation key for Secure Shell access to Linux operating system.

- CODESYS Runtime Engine for running IEC 61131-3 compliant programs created with the CODESYS Development Environment. All IEC 61131-3 languages are supported, including Function Block Diagram (FBD), Structured Text (ST), Sequential Function Charts (SFC), and Ladder Diagram (LD). (Requires the free CODESYS Runtime Engine License, GROOV-LIC-CRE.)

You can run complex control programs on the *groov* EPIC processor developed with:

- PAC Control, a flowchart-based programming language
- CODESYS Development System V3, an IEC 61131-3- compliant programming language
- Python, C/C++, JavaScript, and other popular software development tools (requires free SSH License, GROOV-LIC-SHELL)

The *groov* Manage app gives you central command-like access to your *groov* EPIC system, helping you configure, troubleshoot, and commission your system. The consistency in interface design between the *groov* Manage app running on the *groov* EPIC processor and the *groov* Manage app running on your computer, smartphone, or tablet ensures a seamless experience between devices. You don't have to remember to do something different for each device to achieve the same result.

groov View offers easy browser-based, mobile-ready development of a custom HMI with trending, events, and user notification. Communication is secured with user authentication and TLS encryption. And, because the HMI is web server-based, what you build can be viewed on any authorized device with a web browser.

OptoSupport Remote Support Service (RSS)

Support has never been closer! With OptoSupport RSS, you can create a secure, encrypted connection between your *groov* EPIC controller and Opto 22's support team so they can remotely help diagnose and troubleshoot any issues. The remote connection can only be started by you, and only after you and an Opto 22 support team member have determined that the best way to help you is through a remote connection.

The *groov* EPIC system

The GRV-EPIC-PR1 is part of the *groov* EPIC system, which provides a complete control and communications system at the network's edge, including:

- **I/O.** Connect to field devices and translate their electrical signals into the ones and zeros that computer systems understand.
- **Control.** Automate equipment and systems at the network's edge. Create flowchart-based strategies, IEC 61131-3 compliant programs, or custom developed applications with popular software development tools.

- **Connectivity and Data handling.** Acquire, move, and share data from industrial systems, legacy equipment, business and IT systems, and the cloud through a variety of connecting technologies like Node-RED, REST API, Ignition SCADA, OptoDataLink, and OptoOPCServer.
- **Visualization.** Securely monitor, control, and use data as you need it—locally, on premises, or from anywhere using *groov* View. Authorized users can view your operator interface on the *groov* EPIC processor, a mobile device, a computer, or anything with a web browser.

The *groov* EPIC system builds on decades of field-proven design and modern open standards to give you reliable industrial automation plus a full internet of things (IoT) suite of tools and technologies, built in.

The system includes processor, software, I/O modules, chassis, and power supply.

The chassis holds the power supply, processor, and selected, modular I/O modules you need for your application. For more information, see the [groov EPIC Chassis Data Sheet \(form 2247\)](#).

Power supplies are available for AC power, DC conversion, and pass-through connections from a DC power supply you already own. For more information, see the [groov EPIC Power Supplies Data Sheet \(form 2246\)](#).

The *groov* I/O modules connect a variety of field devices to your *groov* EPIC system. The table on the following page lists the available I/O modules and the form numbers to learn more about them.

groov I/O MODULES

Module description	Part numbers	Form number
groov 115 VAC Input Modules	GRV-IAC-24, GRV-IACS-24, GRV-IACI-12, GRV-IACIS-12	2226
groov 180–280 VAC Input Modules	GRV-IACHV-24, GRV-IACHVS-24, GRV-IACIHV-12, GRV-IACIHVS-12	2222
groov DC Input Modules	GRV-IDC-24, GRV-IDCS-24, GRV-IDCI-12, GRV-IDCIS-12, GRV-IDCIFQ-12	2236
groov 2–16 VAC VDC Input Modules	GRV-IACDCTL-24, GRV-IACDCTLS-24	2237
groov 12–250 VAC Output Modules	GRV-OAC-12, GRV-OACI-12, GRV-OACS-12, GRV-OACIS-12	2231
groov 5–60 VDC Output Modules	GRV-ODCI-12, GRV-ODCIS-12	2238
groov DC Output Sourcing Module	GRV-ODCSRC-24	2242
groov Mechanical Relay Output Module	GRV-OMRIS-8	2243
groov ICTD Temperature Input Module	GRV-IICTD-12	2300
groov Thermistor/Resistor Input Module	GRV-ITR-12	2301
groov Analog Current Input Module	GRV-IMA-24, GRV-IMAI-8	2239
groov Analog Thermocouple/Millivolt Input Module	GRV-ITMI-8	2240
groov Analog Voltage Input Module	GRV-IV-24	2241
groov Analog Voltage and Current Output Module	GRV-OVMALC-8, GRV-OVMAILP-8	2244
groov Serial Module	GRV-CSERI-4	2296

SPECIFICATIONS

Specification	GRV-EPIC-PR1
Power requirements	7.1 W typical, 9.1 W max.
Memory	2 GB RAM 2 MB battery-backed RAM 6 GB user space
Backup battery for real-time clock	BR2032
Screen size and resolution	5 inches diagonal; 480 x 800 pixels
Ethernet Communication (wired)	Two independent 10/100/1000 Mbps RJ-45 connectors, each with a separate IP address (separate subnets)
USB	USB 2.0 (two ports; can be used to connect serial devices via a USB-to-serial converter with an FTDI chipset)
HDMI	Connector Type: A HDMI Specification: Version 1.4a Max. Resolution: 1920 x 1080 pixels at 60 Hz
Torque, bottom hold-down screw	3.5 in-lb (0.4 N-m)
Torque, top hold-down screw	1.5 in-lb (0.17 N-m)
Operating temperature	-20 °C to +70 °C
Storage temperature	-40 °C to +85 °C
Relative Humidity (non-condensing)	5–95%
Agency approvals and certifications	UL/cUL (Class 1 Div. 2); CE, ATEX (Category 3, Zone 2), RoHS; DFARS
Warranty	30 months

Device Compatibility

The following USB devices have been tested to be compatible with the *groov* EPIC processor for the function listed.

Serial communication

The following USB-to-serial adapters have been tested and proven to be compatible with the *groov* EPIC system.

Device Manufacturer	Model
B&B Electronics	USOPTL4 (isolated RS-485) USPTL4 (non-isolated RS-485) USO9ML2 (isolated RS-232)
Gearmo	GM-482422 (non-isolated RS-485/RS-422) GM-FTD1-A12 (non-isolated RS-232) SERIAL-B (non-isolated RS-232)

Wireless communication

The following WiFi USB adapters have been tested and proven to be compatible with the *groov* EPIC system:

Device Manufacturer	Model
Netis®	WF2180 WF2190

INSTALLING AND REMOVING THE PROCESSOR

Installing the processor

1. Make sure you installed the power supply according to the directions in the [groov EPIC Power Supplies, Converters, and Adapters Data Sheet](#) (form 2246).
2. Review "Processor orientation" on page 6 to understand which side of the processor is the top, underside, back, and face.
3. Lift open the LCD display so you can see the notch on the processor.
4. Hold the processor by the left side, and make sure that the notch on the processor aligns with the guide tab on the power supply.
5. Guide the processor straight onto the chassis, flush against the side of the power supply, pushing until you feel the processor slide firmly into the chassis and the processor resists further pressure.

You can push on the processor to ensure that it is firmly inserted.

IMPORTANT: Do not push on the LCD display.

6. Tighten the retention screws that attach the processor to the power supply and the chassis to the recommended torque listed in "Specifications" on page 4.
7. Close the LCD display.

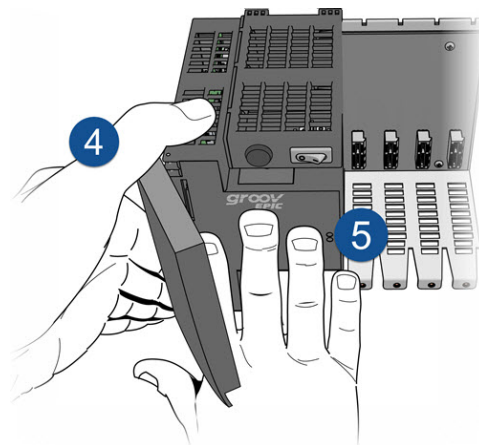
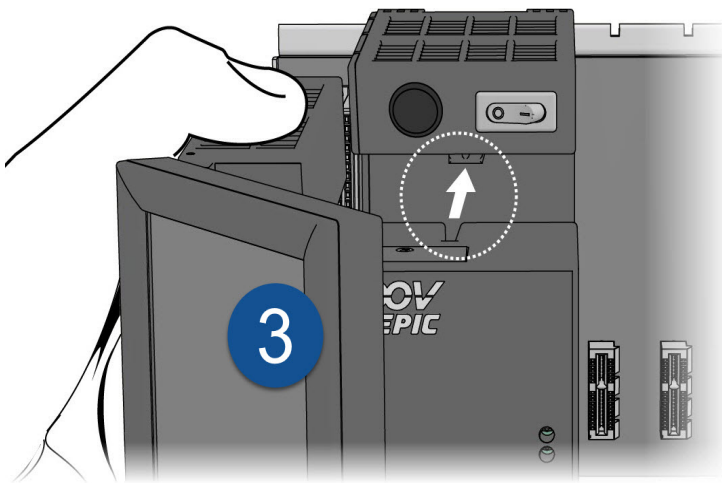

Removing the processor

1. Lift the LCD display so that you can access the retention screws and power switch.
2. Turn off the unit.

IMPORTANT: Do not attempt to remove the processor and power supply as a single unit.

3. Remove the retention screws that attach the processor to the power supply and the chassis.
4. Hold the processor with both hands, one hand on the left side and the other hand at the top.

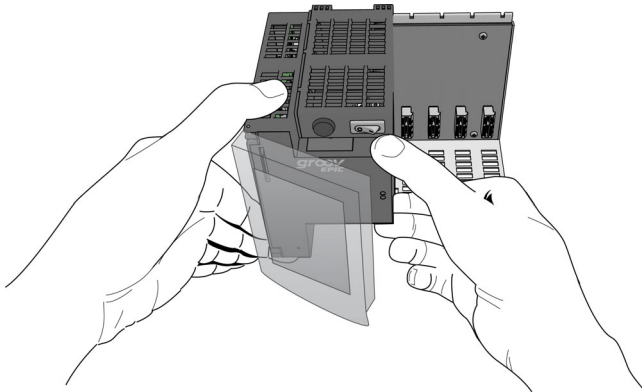

IMPORTANT: Do not attempt to remove the processor by grasping the screen.

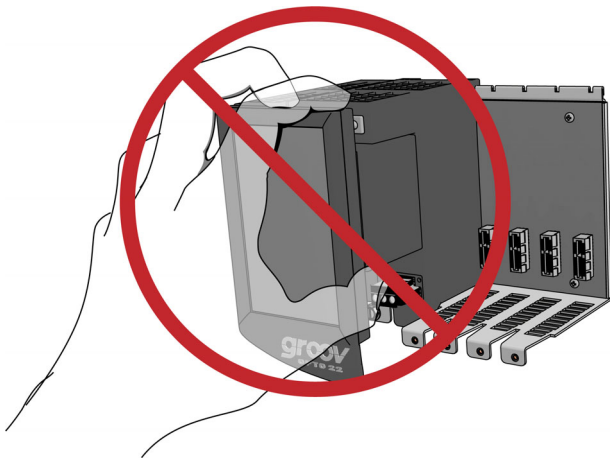

5. Pull the processor straight out. Do not wiggle the processor.

IMPORTANT: Handle and carry the processor only by the plastic case. Do not touch any of the exposed circuitry.

6. Close the LCD display.

PROCESSOR ORIENTATION

The following diagram identifies which side of the processor is the bottom or underside, the face, the top and the back. This helps orient you when you are reading the installation and removal instructions.

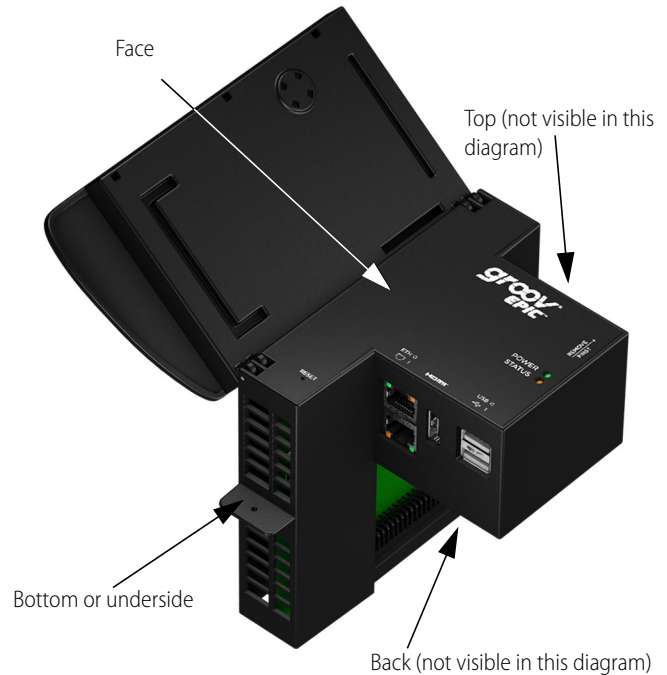

LCD DISPLAY

The LCD display features resistive-touch capability, which means you can manipulate the display with gloved fingers or a stylus (not included).

The LCD display is your window to both your control system and HMI. With *groov* Manage, you can:

- Configure and troubleshoot the *groov* I/O modules mounted on the chassis.
- Configure the Ethernet network interfaces and the firewall, and create rules to control access to the ports.

- View the current state of input channels and set the state of output channels.
- Access a library of information about all of the *groov* I/O modules available through Opto 22, including specifications and wiring diagrams.
- Review logs for troubleshooting.

The LCD displays your *groov* View HMI, which you can build and configure within your web browser on your PC.

groov Manage

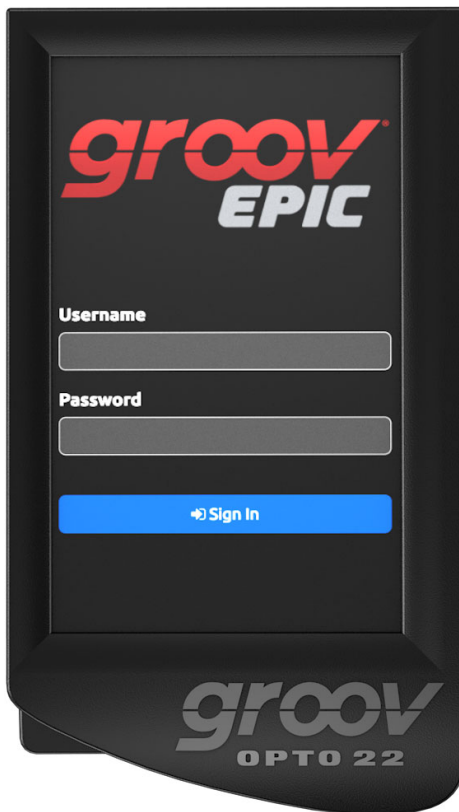

groov View HMI

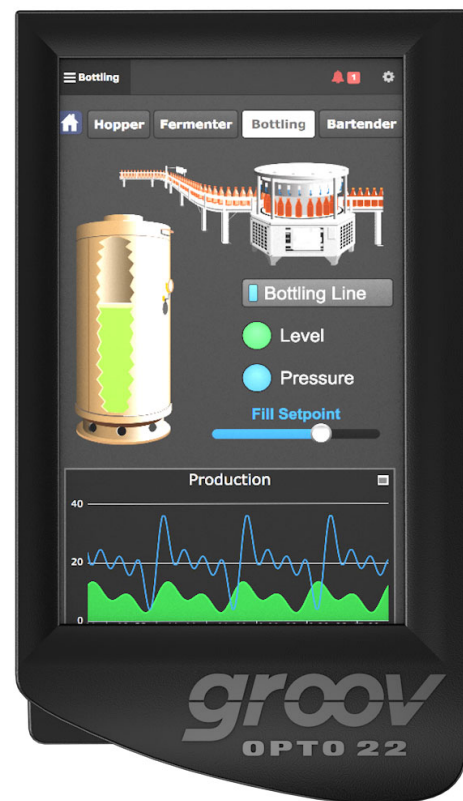

LEDs, NETWORK INTERFACES, AND PORTS

The diagram below describes the LEDs, network interfaces, and ports on the *groov* EPIC processor. All of these interfaces and indicators are easily accessed by lifting the hinged LCD display. When the LCD display is closed, it does not interfere with cables connecting the processor to external devices such as an external monitor. For more information about LEDs, network interfaces, and ports, see [groov EPIC User's Guide](#) (form 2267).

LEDs

LED	Indicates
SPEED LED	Indicates link speed (Off = 10 Mbps, Green = 100 Mbps, Orange = 1000 Mbps)
LINK ACT LED	Indicates link status or activity (on/solid = link present, blinking = link present and local activity)
POWER	Indicates status of power (Green = on; Red = on, resetting)
STATUS	Indicates whether the unit is running with full functionality. (Green = all normal; blink green and red = starting a restore to defaults)

Ports

The HDMI port offers a connection to an external monitor, such as an HDMI-ready touch-screen monitor, so that you can display *groov* Manage or your *groov* View HMI on a separate screen.

The two USB ports offer several ways to extend the capabilities of the processor. You can connect:

- Serial devices via a USB-to-serial converter
- A mouse, keyboard, or both to make it easier to type in data and navigate through the screens
- WiFi adapters to add wireless connectivity

For device compatibility information, see “[Device Compatibility](#)” on page 4.

Independent Ethernet network interfaces

The Ethernet network interfaces are independent, which means they are not connected internally. Each requires its own IP address, and the two interfaces must be on different subnets.

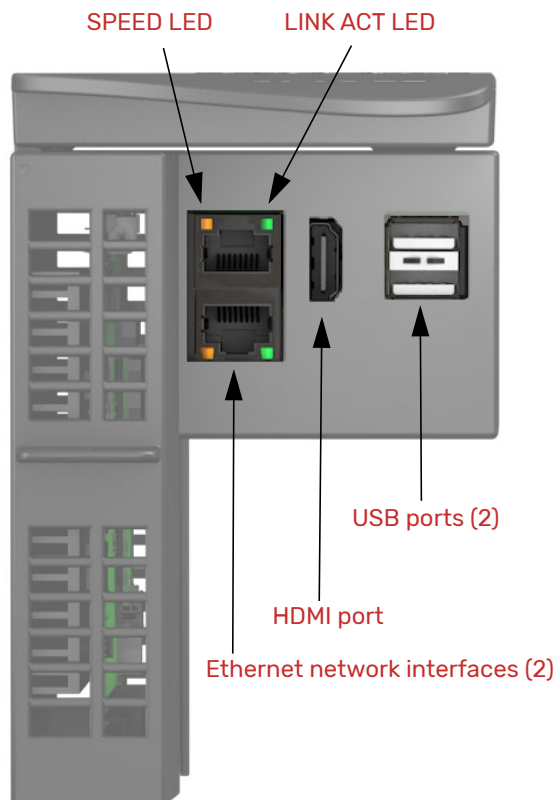

The labels on the face of the processor identify the locations of the interfaces and ports, which are on the underside of the processor, as shown on the image to the left.

DIMENSIONS: GRV-EPIC-PR1

The processor features an LCD display that swings open and closed. The diagram to the right shows the LCD display open to its fullest extent. The diagram below shows the LCD display closed.

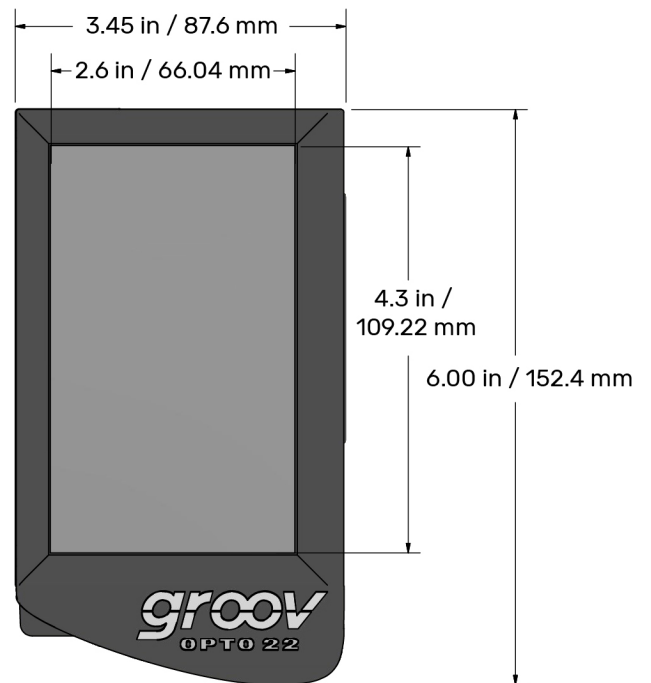
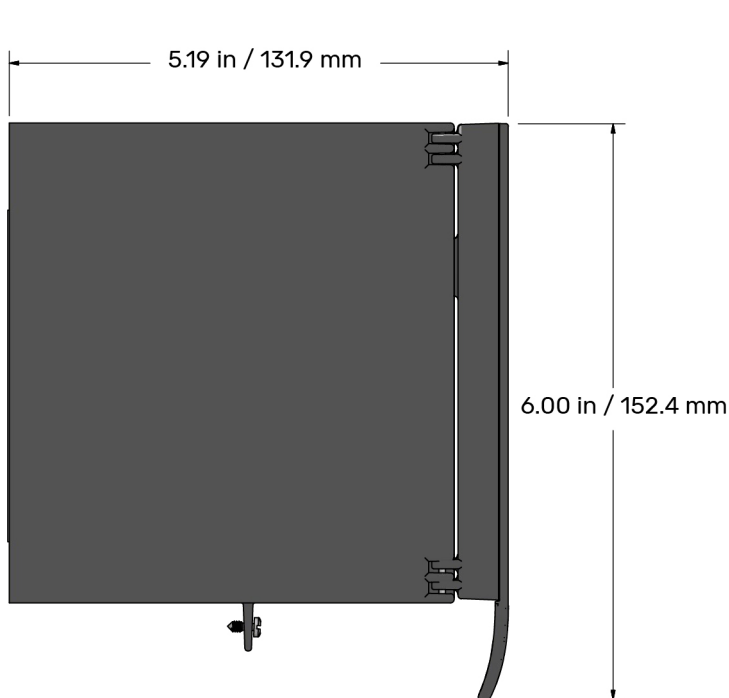
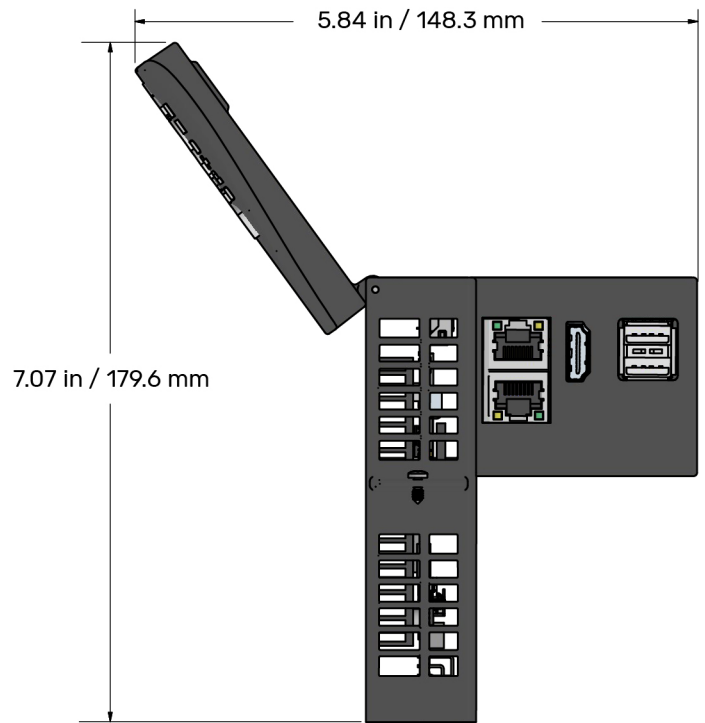
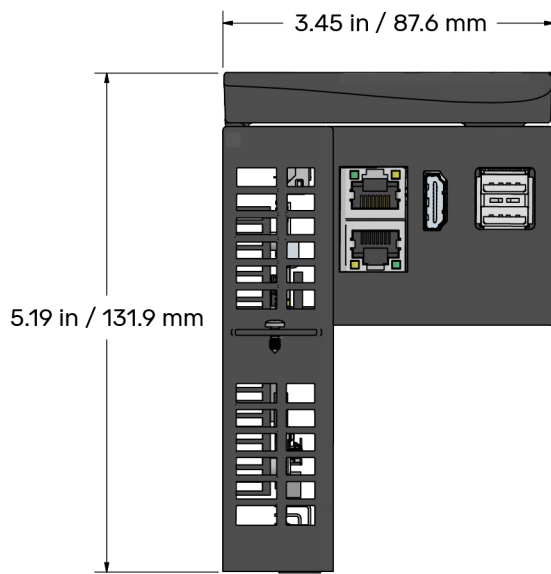

HARDWARE ARCHITECTURE

groov EPIC Power Supply

Available in three models:

- AC power supply
- DC power converter
- Pass-through power adapter

groov I/O Modules

- Removable cage-clamp field wiring connector with single, captive hold-down screw
- Pivoting, two-position cover
- Touch-sensitive pad
- Hot swappable
- LEDs indicate module health and channel status
- UL Hazardous Locations approved and ATEX compliant

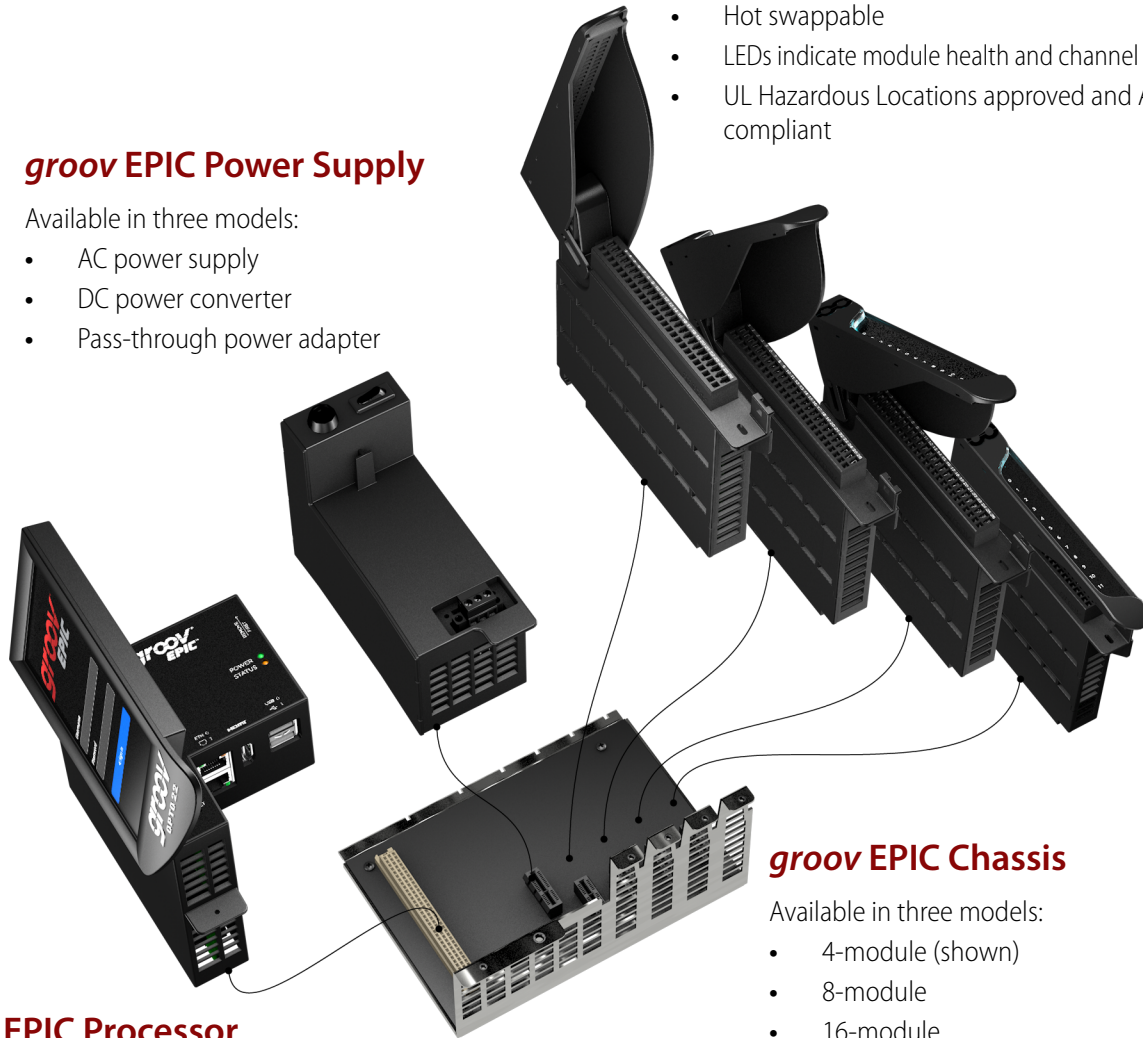

groov EPIC Processor

- Web-based commissioning, troubleshooting, and *groov* View HMI
- Compatible with PAC Project Basic (installs on Windows computer)
- Pre-installed software: *groov* Manage, *groov* View, Node-RED, Ignition Edge, and CODESYS Runtime Engine
- LCD touch display
- Dual USB ports for serial communications or touchscreen monitors
- HDMI port for external monitors, touchscreens, and WiFi adapters
- Dual independent Gigabit Ethernet network interfaces
- Supports up to 16 *groov* I/O modules

groov EPIC Chassis

Available in three models:

- 4-module (shown)
- 8-module
- 16-module

PRODUCTS

Opto 22 develops and manufactures reliable, easy-to-use, open standards-based hardware and software products.

Industrial automation, process control, building automation, industrial refrigeration, remote monitoring, data acquisition, and industrial internet of things (IIoT) applications worldwide all rely on Opto 22.

groov EPIC® System

Opto 22's *groov* Edge Programmable Industrial Controller (EPIC) system is the culmination of over 40 years of experience in designing products for the automation industry.

groov EPIC gives you an industrially hardened system with guaranteed-for-life I/O, a flexible Linux®-based controller with gateway functions, and software for your IIoT application or any application.

groov EPIC I/O

I/O provides the local connection to sensors and equipment. *groov* I/O offers up to 24 channels on each I/O module, with a spring-clamp terminal strip, integrated wireway, and swing-away cover.

Opto 22 I/O is so reliable, we can afford to guarantee it for life. *groov* I/O is hot swappable, UL Hazardous Locations approved, and ATEX compliant.

groov EPIC Processor

The heart of the system is the *groov* EPIC processor. It handles a wide range of digital, analog, and serial functions for data collection, remote monitoring, process control, and discrete and hybrid manufacturing.

In addition, the EPIC provides secure data communications among physical assets, control systems, software applications, online services, and more, both on premises and in the cloud.

Configuring and troubleshooting I/O and networking is easier with the EPIC's integrated high-resolution touchscreen. Authorized users can see your *groov* View HMI locally on the touchscreen or on a monitor connected via the HDMI or USB ports.

groov EPIC Software

Software included in the *groov* EPIC controller:

- PAC Control engine to run PAC Control strategies and PAC Display projects
- CODESYS Runtime engine to run IEC61131-3 compliant programs built with CODESYS Development System

- Access to the Linux operating system through a secure shell (SSH) to download and run custom applications
- *groov* View for building and viewing your own device-independent HMI
- Node-RED for creating simple logic flows from pre-built nodes
- Ignition Edge® from Inductive Automation®, with OPC-UA drivers to Allen-Bradley®, Siemens®, and other control systems, and MQTT/Sparkplug communications for efficient IIoT data transfer

Older products

From solid state relays (our first products) to world-famous G4 and SNAP I/O, to SNAP PAC controllers, Opto 22 products last a long time. You can count on us to give you the reliability and service you expect.

QUALITY

Founded in 1974, Opto 22 has established a worldwide reputation for high-quality products. All are made in the U.S.A. at our manufacturing facility in Temecula, California.

Because we test each product twice before it leaves our factory rather than testing a sample of each batch, we can guarantee most solid-state relays and optically isolated I/O modules for life.



FREE PRODUCT SUPPORT

Opto 22's California-based Product Support Group offers free, comprehensive technical support for Opto 22 products from engineers with decades of training and experience. Support is available in English and Spanish by phone or email, Monday–Friday, 7 a.m. to 5 p.m. PST.

Support is always available on our website, including online training, how-to videos, user's guides, the Opto 22 KnowledgeBase, troubleshooting tips, and OptoForums. In addition, free hands-on training is available at our Temecula, California headquarters, and you can [register online](#).

PURCHASING OPTO 22 PRODUCTS

Opto 22 products are sold directly and through a worldwide network of distributors, partners, and system integrators. For more information, contact Opto 22 headquarters at **800-321-6786** (toll-free in the U.S. and Canada) or **+1-951-695-3000**, or visit our website at www.opto22.com.