

LANTRONIX®



xPico™
Development Kit
Quick Start

Vertrieb durch
Distribution by

HY-LINE®
COMPUTER COMPONENTS

Inselkammerstr. 10
D-82008 Unterhaching
Tel.: +49 89 614 503 40
www.hy-line.de

Part Number 900-623
Revision C March 2013

Copyright and Trademark

© 2013 Lantronix, Inc. All rights reserved. No part of the contents of this book may be transmitted or reproduced in any form or by any means without the written permission of Lantronix.

Lantronix® and DeviceLinx® are registered trademarks of Lantronix, Inc. xPico™ and DeviceInstaller™ are trademarks of Lantronix, Inc.

UNIX® is a registered trademark of The Open Group. Windows® is a trademark of Microsoft Corporation. All other trademarks and trade names are the property of their respective holders.

Warranty

For details on the Lantronix warranty replacement policy, please go to our Web site at www.lantronix.com/support/warranty.

Contacts

Lantronix, Inc.

167 Technology Drive
Irvine, CA 92618, USA

Toll Free: 800-526-8766

Phone: 949-453-3990

Fax: 949-450-7249

Technical Support

Online: www.lantronix.com/support

Sales Offices

For a current list of our domestic and international sales offices, go to the Lantronix web site at www.lantronix.com/about/contact.

Revision History

Date	Rev.	Comments
April 2012	A	Initial release.
August 2012	B	Updated for the new revision of the evaluation board.
March 2013	C	Updated for the new xPico Modbus module.

Table of Contents

Table of Contents	3
Introduction	4
Development Kit Contents	4
What You Need to Know	4
Hardware Address	4
IP Address	4
Connecting an xPico Module — Network Method	5
Connecting an xPico Module — Serial Method	6
Install DeviceInstaller	6
Assign an IP Address	7
Configure Your xPico Device	9
xPico Module	9
xPico-IAP Module	9

Introduction

Thank you for purchasing the xPico Development Kit from Lantronix.

This Quick Start guide describes the procedures for initial connection to the xPico module through either a network connection or serial port.

Once a connection is established you can use the WebManager or Setup Mode for configuration and control.

Development Kit Contents

Note: *The xPico Evaluation Board is designed to work with the family of xPico serial to Ethernet modules. Please ensure that you have the correct module for your needs. The Evaluation Kit comes with the standard xPico serial to Ethernet device. If you wish to use the xPico-IAP then please ensure that you have the XPC10010MS-01 or later module.*

- ◆ xPico Module
- ◆ xPico Evaluation Board
- ◆ Two xPico Mounting Quick Clips (one installed)
- ◆ Sample 40-pin Mating Connector
- ◆ 5V Wall-mount Power Supply AC/DC, 1A
- ◆ RS-232, DB9F/F, 10 ft, Null Modem Cable
- ◆ Ethernet Cable 10 ft

For the latest revision of this product document, please check our online documentation at www.lantronix.com/support/documentation.

What You Need to Know

Hardware Address

You need to know the unit hardware address (also known as MAC address) to identify the unit in the Device Installer search list. It is on the product label in the format: 00-80-A3-XX-XX-XX, where the XXs are unique numbers assigned to the product.

Hardware Address: 00-80-A3-_____-_____-_____

IP Address

Your xPico will need a unique IP address on your network. By default, the xPico module is assigned an IP address by your DHCP server. If no DHCP server is available, the xPico will generate an AutoIP address (169.254.xxx.xxx).

If you are planning to use a static IP address, make note of it. The system administrator generally provides the IP address, subnet mask, and gateway. The IP address must be within a valid range, unique to your network, and in the same subnet as your PC.

IP Address: _____

Subnet Mask: _____

Gateway: _____

Connecting an xPico Module — Network Method

A network connection, if the equipment is available, is the preferred method for the initial configuration of the xPico.

Note: Before wiring and powering on the xPico Evaluation Board please make sure that the correct xPico module for your needs is fitted. Removing and inserting the xPico module is quite simple and requires removing the fitted mounting clip and exchanging the module in the 40-pin socket.

1. Connect the PC to the Evaluation Board with a cross-over cable or a hub/switch and two RJ45 cables. Make sure there is no router between the PC and the Evaluation Board.

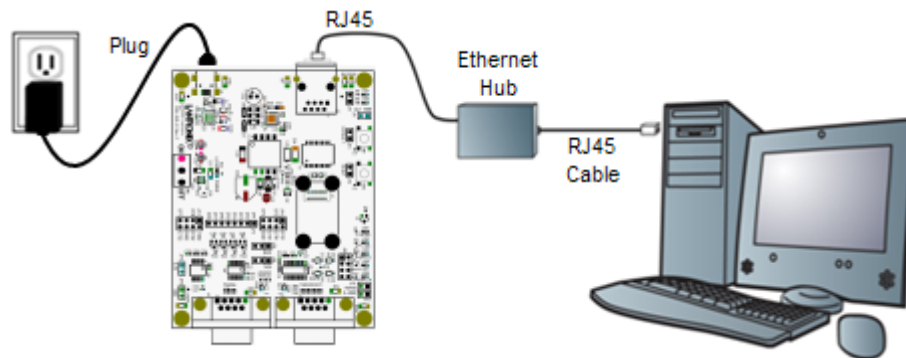

2. Select the appropriate power plug adaptor for your geographical location. Insert it into the slot on the Universal Power Supply; then plug the power supply into an outlet.
3. Connect the output plug of the power supply to the Evaluation Board.
4. Move the power switch on the Evaluation Board to **ON**.
This is the last step in 'connection.' The xPico is ready for configuration.
5. Continue with [Install DeviceInstaller on page 6](#).

Connecting an xPico Module — Serial Method

In the event that the equipment required for a network connection is not available for the initial configuration of the xPico, the serial method can be used.

1. Connect one end of the supplied DB9F/F serial cable to the serial port on the laptop or desktop.
2. Connect the other end of the supplied DB9F/F serial cable to Port 1 on the xPico Evaluation Board.
3. Select the appropriate power plug adaptor for your geographical location. Insert it into the slot on the Universal Power Supply; then plug the power supply into an outlet.
4. Connect the output plug of the power supply to the xPico Evaluation Board. The final serial connection setup should look like this:

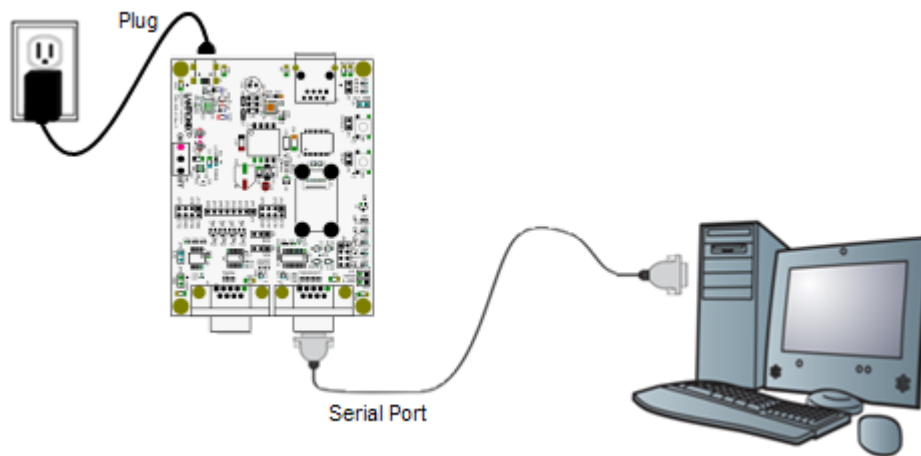

5. Move the power switch on the Evaluation Board to **ON**.
This is the last step in 'connection.' The xPico is ready for configuration.
6. Continue with the Install DeviceInstaller section below.

Install DeviceInstaller

Use DeviceInstaller to configure the IP address and other network parameters.

Note: You will need a Windows PC running Lantronix DeviceInstaller 4.3.0.5 or higher.

1. Download the latest version of DeviceInstaller from www.lantronix.com/downloads.
2. Run the executable to start the installation process.
3. Respond to the installation wizard prompts. (If prompted to select an installation type, select **Typical**.)

Note: For more information about DeviceInstaller, see the [DeviceInstaller Online Help](#).

Assign an IP Address

The unit IP address is set for DHCP by default at the factory. The hardware address is on the product label. Assign a static IP address if you do not want the network to assign an IP address to the xPico or do not have a DHCP server on the network.

1. Click **Start**→**Programs** → **Lantronix**→**DeviceInstaller**→**DeviceInstaller**. If your PC has more than one network adapter, a message appears. Select an adapter and click **OK**.
2. Click the **Search** icon and select the unit from the list of Lantronix device servers on the local network. (In case no DHCP server is available, it can take 30 seconds before an AutoIP address is generated and the unit is detectable).
3. Click the **Assign IP** icon .
4. Select Assign a specific IP address and click **Next**.

Assignment Method

Would you like to specify the IP address or should the unit get its settings from a server out on the network?

Obtain an IP address automatically

Assign a specific IP address

5. Enter the IP address.
The Subnet mask appears automatically based on the IP address.
You may change it. On a local network, you can leave the Default gateway blank (all zeros).

IP Settings

Please fill in the IP address, subnet, and gateway to assign the device. The subnet will be filled in automatically as you type, but please verify it for accuracy. Incorrect values in any of the below fields can make it impossible for your device to communicate, and can cause network disruption.

IP address:	<input type="text" value="0.0.0.0"/>
Subnet mask:	<input type="text" value="0.0.0.0"/>
Default gateway	<input type="text" value="0.0.0.0"/>

6. Click **Next**.
7. Click **Assign** and wait several seconds until a confirmation message appears.
8. Click **Finish**.
9. Select the xPico from the main window list and click **Tools→Ping**. The results appear in the Status area.

The screenshot shows a window titled "IP Address:" with a text input field containing "172.19.238.20". To the right of the input field are two buttons: "Ping" and "Clear Status". Below the input field is a "Status:" label followed by a scrollable text area containing four lines of ping results: "Reply from 172.19.238.20:0: bytes=60 time=0ms TTL=64". At the bottom right of the window is a "Close" button.

10. Click **Clear Status** to clear the window to ping the device again.

Note: If you do not receive “Reply” messages, ensure the IP address assigned is valid for the particular network segment you are working with.

11. Click **Close**.

Configure Your xPico Device

Using DeviceInstaller it is easy to configure the unit over the network.

xPico Module

From DeviceInstaller it is easy to start the Lantronix browser-based tool, “Web Manager” to configure the xPico. For detailed information on Web Manager configuration and on other methods, see the *xPico User Guide*.

1. In DeviceInstaller, select the unit and then the **Web Configuration** tab. Click the **Go** icon. The Lantronix Web Manager login window appears.
2. For the xPico, there is no default user name or password, so just click **OK**.
3. Use the menu on the left to navigate to sub-pages where you can configure the xPico module.
4. Commit any changes as follows:
 - Every sub-page has an **OK** button that tells the xPico what changes to use, but it does not immediately change the configuration on the device.
 - When you are finished making all changes to the settings on various pages, then click **Apply Settings**, which makes the changes permanent and reboots the xPico.

xPico-IAP Module

From DeviceInstaller it is easy to start a Telnet connection to configure the unit over the network. For detailed information on configuration, see the Modbus Protocol User Guide.

1. In DeviceInstaller, select the unit and then the **Telnet Configuration** tab.
2. Click the **Connect** icon. The following information displays:

```
Lantronix Inc. - Modbus Bridge
MAC address 0080A366000D
Software version V3.3.0.0 (130306) XPICO
```

```
Press Enter for Setup Mode
```

3. To enter Setup Mode, press **Enter** within 5 seconds. The configuration settings display, followed by the change prompt:

```
Select Command or parameter set (1..7) to change:
```
4. Select an option on the menu by entering the number of the option and pressing **Enter**.
5. To enter a value for a parameter, type the value and press **Enter**, or to confirm a current value, just press **Enter**.
6. When you are finished making all changes to the various settings, use the **(S)**ave option to save the new configuration by entering S. The unit automatically reboots.