

# Measuring converter **AD4ETH**

4 inputs for standardized signal measuring  
0 - 10 V, 0 - 20 mA, 4 - 20 mA, ...

Communication via Ethernet



# AD4ETH

## Datasheet

Created: 9/1/2007

Last update: 4/23/2010 1:52 PM

Number of pages: 45

© 2010 Papouch s.r.o.



Inselkammerstraße 10  
82008 Unterhaching

Tel: 089 / 614 503 81  
Fax: 089 / 614 503 85

E-Mail: [systems@hy-line.de](mailto:systems@hy-line.de)

Internet: [www.hy-line.de](http://www.hy-line.de)

**CONTENT**

First start.....	5
Basic information .....	5
Description.....	5
Application .....	6
Features .....	6
AD4ETH .....	7
Block diagram and operation .....	9
Connectors .....	9
Measuring terminals.....	9
Power supply .....	10
Ethernet.....	10
Examples of connection structure .....	11
Voltage measurement.....	11
Sensors with output of 0 to 20 mA and own power supply .....	11
Sensors with output of 0 to 20 mA, supplied through current loop.....	12
WEB interface.....	13
WAP .....	14
Communication via TCP/UDP (Spinel).....	15
TCP server .....	15
TCP client.....	16
UDP .....	16
Current values in XML format.....	17
Sending the values by HTTP protocol (GET and Post) .....	18
HTTP GET .....	19
HTTP POST (SOAP) .....	20
Informative E-mails sending.....	21
SNMP protocol.....	22
Analogue input name .....	22
Analogue input status .....	22
Measured value .....	22
Units .....	22
Values monitoring .....	23
Upper limit .....	23
Lower limit .....	23
Limits hysteresis .....	23
Device name.....	23
Trap text .....	23
MODBUS protocol .....	24
Current value reading .....	25

---

Konfigurace.....	26
Configuration via WEB interface .....	26
Network .....	26
E-mail .....	28
Security.....	30
SNMP .....	31
MODBUS .....	32
Sending .....	33
Other.....	34
Channel .....	35
Basic Setup via Telnet .....	38
Connection .....	38
IP address is not known .....	38
IP address is known.....	39
Main Menu .....	39
Server.....	39
Factory Defaults .....	40
Exit without save .....	40
Save and exit.....	40
IP address change .....	41
Universal Software.....	41
Technical parameters.....	43
Available Designs .....	44
Indications.....	45

## FIRST START

1. Connect all connectors according to chapter [Connectors](#) on the page [9](#). (It is sufficient to connect power and Ethernet for the first time.)
2. If the default IP address 192.168.1.254 is not acceptable for your computer network, change it by means described in chapter [IP address change](#) on the page [41](#).
3. Enter the IP address of your AD4ETH to the WEB browser<sup>1</sup>. Default IP address is <http://192.168.1.254/>.
4. AD4ETH WEB page in Administrator mode will open. There is an icon of a tool in the upper right corner. You can use this icon to access device settings. You can view help by pointing the cursor at the given text field.

## BASIC INFORMATION

### Description

AD4ETH measuring converter is a 4-input A/D converter which enables the user to measure to four current inputs ranging from 0(4) to 20 mA or voltage between 0 and 10 V. The measured values are then transferred to a superior system in digital form. AD4ETH has been produced in three versions differing in their communication interface – the data can be transferred via RS232/RS485 lines, over USB interface or the Ethernet. The AD4ETH version communicates via Ethernet.

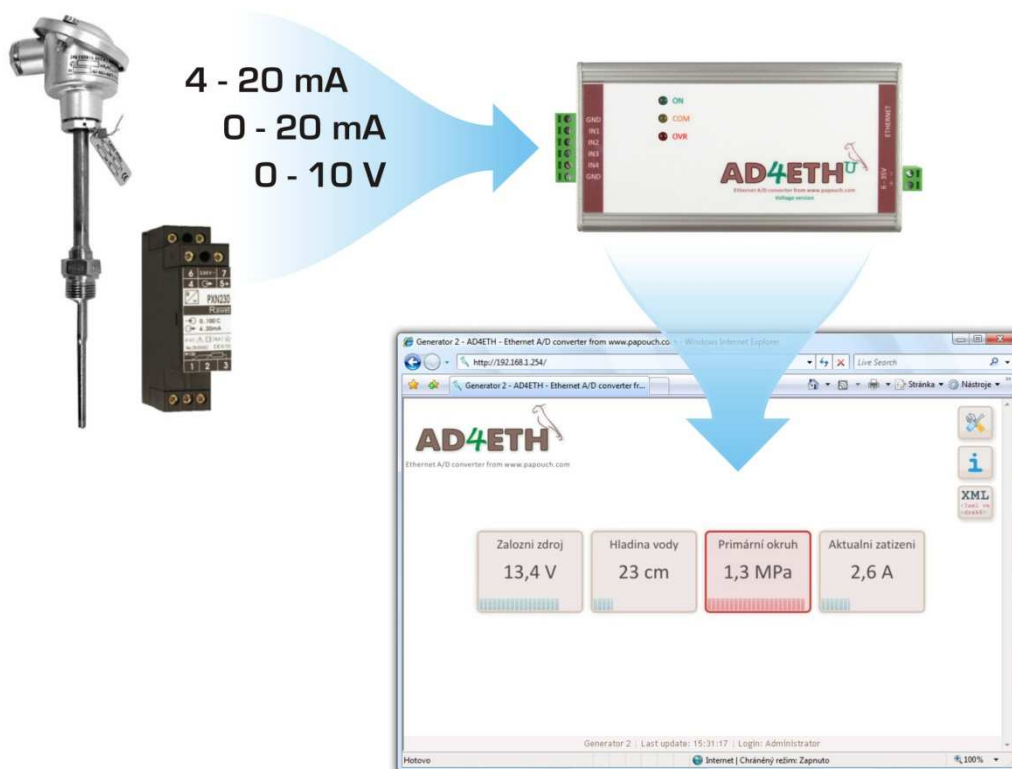

<sup>1</sup> WEB interface is optimized for viewing on PC in at least 1024 by 768 pixels. Also it is optimized for Internet Explorer 6.0 or 7.0 and Firefox 2.0 browsers. JavaScript has to be allowed.

## Application

---

- Measurement of values from sensors with voltage or current output.
- Reading of sensors whose output is a standardised current signal
- Digitalisation of measured values from level, pressure, temperature, distance and other sensors
- Remote supervision over applications indicated above.

## Features

---

- Four analogue inputs for current or voltage
- Measuring scale divided into 10 000 divisions
- Full isolation of the measuring part from power supply and communication lines
- Measurements carried out by a multiplex 16 bit sigma-delta A/D converter
- The maximum measuring speed of each input equals 406 ms
- Communication via 10/100 Ethernet (Internet)
- Communication protocols TCP/IP (Spinel), UDP/IP (Spinel), SNMP<sup>2</sup>, MODBUS TCP<sup>2</sup>, HTTP (WEB, WAP, XML, SOAP)
- Two different measuring modes are available for TCP or UDP connection:
  - Single measurement – sends one measured value from each input upon a request.
  - Continuous measuring – measures all inputs in the set interval and regularly sends the measured values via the communication line.
- Internal WEB site allowing to view current values and settings.
- WAP pages showing measured values for cell phone or PDA.
- Measured out values and configuration available in XML format.
- Advanced conversion to user defined ranges and units. (For example if the pressure sensor is connected to the AD4ETH, it can be transmitted directly as a value in kPa.)
- Measured values can be transmitted as a POST request (SOAP-XML) or HTTP GET on the WEB server.
- Measuring Wix software for temperatures displaying and storing for Windows
- Wide range of power supply voltage (6 to 35 V)

---

<sup>2</sup> There are two versions of AD4ETH – SNMP type and MODBUS type. Each can contain only one communication protocol. Version is necessary to define when ordering the converter.

## AD4ETH

### 1) WEB page

It is possible to easily monitor the measured values and also to configure AD4ETH over the Intranet interface. The pages are secured by means of user name and password. It is possible to setup a separate password for the configuration and another one for the display of current values. The pages in AD4ETH can be displayed in Czech or English according to the setup. (See [page 13](#) for more information.)

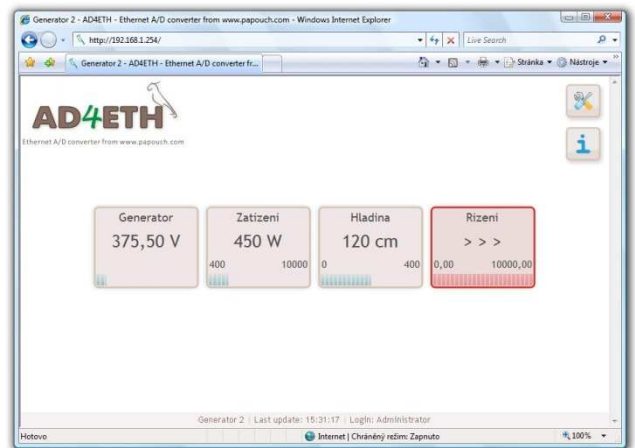

### 2) XML file

It is also possible to import all the values from AD4ETH in the XML file format. This format is easy to process by the application or to read by the web service. (See [page 17](#) for more information.)

```
<input id="2" unit="V" val="375.5" min="370" max="400" name="Generator" ...
```

### 3) WAP page for PDA of mobile phone

AD4ETH contains a simple WAP page with measured data. It is possible to open this page in a mobile phone, PDA or another mobile device. Thus the current status of the device can be viewed whenever needed. (See [page 14](#) for more information.)

### 4) Inserting the current values into the WEB sites (HTTP GET)

AD4ETH enables you to periodically call a script (for example PHP or ASP) on a selected WEB server and to hand the measured values and other parameters over to the server in the form of HTTP GET parameter. Thus you can easily include the currently measured values directly into your WEB site. (See [page 18](#) for more information.)

```
www.myserver.net/ad4eth.php?ch=1&unit=V&val=375.50&min=370& ...
```

### 5) Current values handing-over to the WEB service (HTTP POST, SOAP)

AD4ETH is also able to periodically send the measured data as HTTP POST in the format of XML SOAP (Simple Object Access Protocol). This way is ideal for further processing of the measured values by the WEB service waiting in a server on the Internet or Intranet. This data in the XML format can be easily processed, e.g. in the .NET or PHP environment – there is no need to program any communication protocol, etc. The only thing that needs to be done is to process the delivered XML file. (See [page 19](#) for more information.)

### 6) SNMP protocol

The SNMP protocol is used in large companies for the centralized administration and monitoring of all hardware and technologies. AD4ETH is able to communicate via this protocol and, according to the setup, It sends SNMP traps when the pre-set critical limits

are exceeded. It is also able to periodically send traps with current values. (See page [22](#) for more information.)

#### **7) E-mail**

According to the setup, AD4ETH is able to inform the user via email that the critical limits, pre-defined for individual channels, have been exceeded. (Thanks to services provided by operators it is possible to forward the e-mail easily to a mobile phone as an SMS message.) (See page [21](#) for more information.)

#### **8) TCP or UDP protocol**

AD4ETH is also able to operate as the TCP client or TCP server or to communicate via UDP. The Spinel protocol is used by AD4ETH in these ways of communication. This way of communication is similar to the serial link communication. (See page [15](#) for more information.)

#### **9) MODBUS TCP protocol**

AD4ETH is also able to communicate via the standard industry protocol of MODBUS TCP. (See page [24](#) for more information.)

## BLOCK DIAGRAM AND OPERATION

The measuring part is fully isolated from the communication line and power supply.

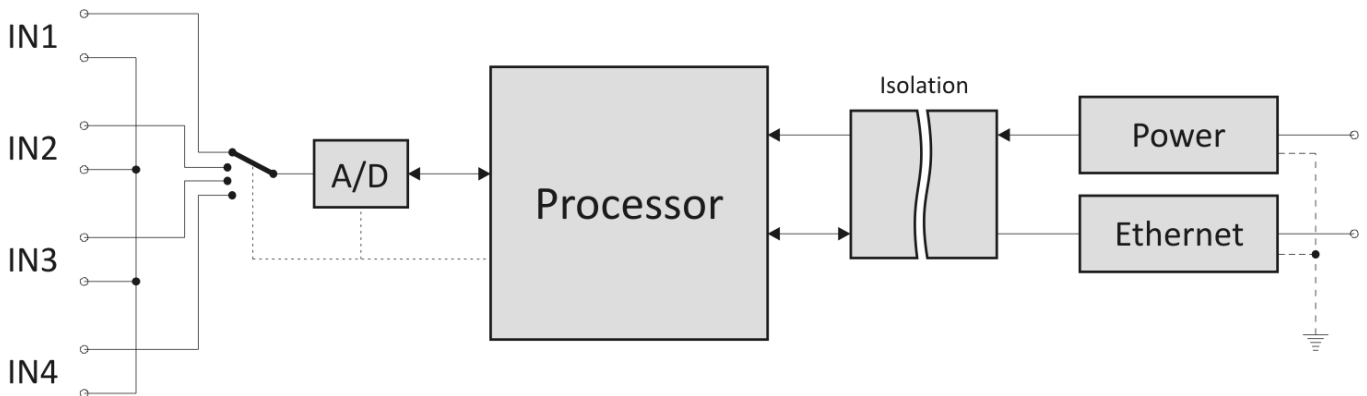

Fig. 1 – Block diagram of AD4ETH

The AD4ETH measuring device uses one switched sigma-delta A/D converter. After switching on the power supply voltage, the processor initiates the A/D converter and set the device parameters according to the data saved in memory. Then the device start to regularly measure the values of voltage found on the analogue inputs and saves the results into the integrated memory.

In the continuous measuring mode AD4ETH sends the measured values in the set interval.

## CONNECTORS

### Measuring terminals

**Note:** The input types (voltage or current) are unchangeable and must be specified by the user when ordering the device. Subsequently they can be changed only by the manufacturer.

The measuring terminal unit is a six-slot terminal unit shown in Fig. 2. It contains four inputs and two grounding terminals.

All four measuring terminals have a joint grounding on the two sides of the terminal unit. This grounding is isolated from other grounding terminals found in the device.

The measuring terminals have been designed for the measurement of voltage of current. Wires can be connected individually and fixed by means of a screw (use flat bladed screwdriver 2.5 mm).

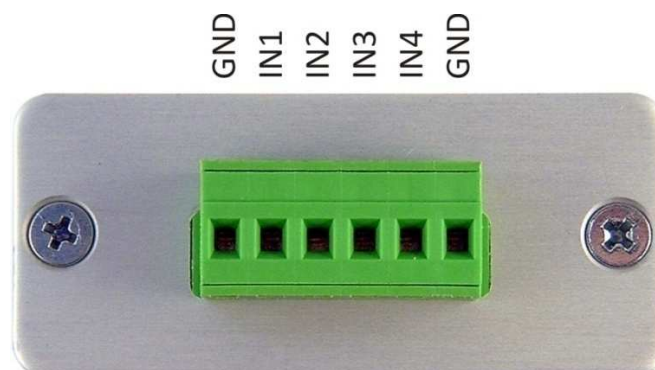

Fig. 2 – measuring terminals

## Power supply

---

DC supply 6 to 35 V shall be connected to the double terminal shown in Fig. 3. The input has an integrated polarity reversal protection.

Wires can be connected individually and fixed by means of a screw (use flat bladed screwdriver 2.5 mm).

## Ethernet

---

Ethernet (computer network interface) is to be connected to a connector in Fig. 3. It is a standardized RJ-45 connector for 100/10 Ethernet.

Connect this connector to the PC via a cross-wired cable or to the switch or hub via a direct cable.

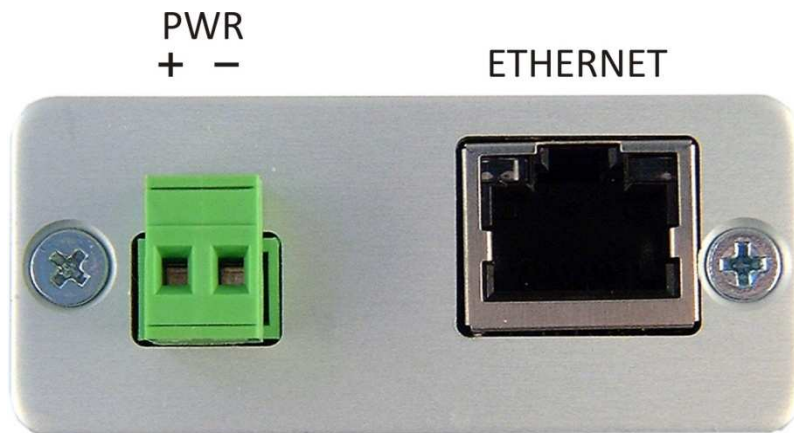

*Fig. 3 – Terminals for power supply connection and RJ45 for Ethernet connection*

## EXAMPLES OF CONNECTION STRUCTURE

The following figures show examples of AD4ETH connection structure.

### Voltage measurement

An example of voltage supply connection to AD4ETH terminals. The inputs are fully isolated from the power supply.

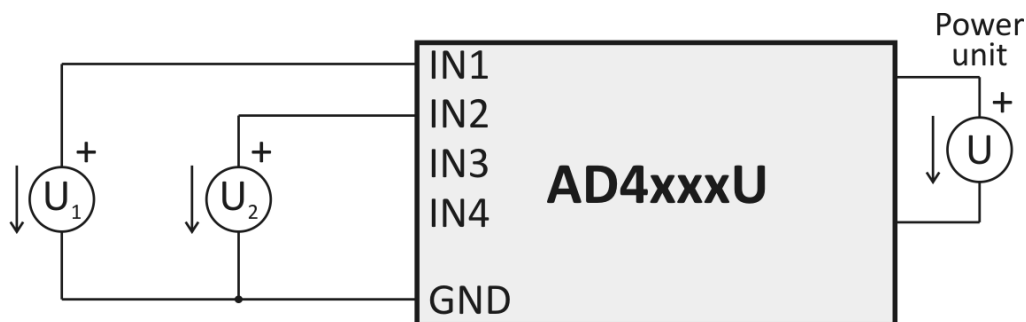

Fig. 4 – Voltage measurement

### Sensors with output of 0 to 20 mA and own power supply

Sensors with currents outputs can be connected directly to the inputs with current range and supplied either from their own power supply (in this case, the sensor is isolated from AD4ETH power supply) or from the same supply as AD4ETH (see the dashed lines in Fig. 5; in this case, sensors are not isolated).

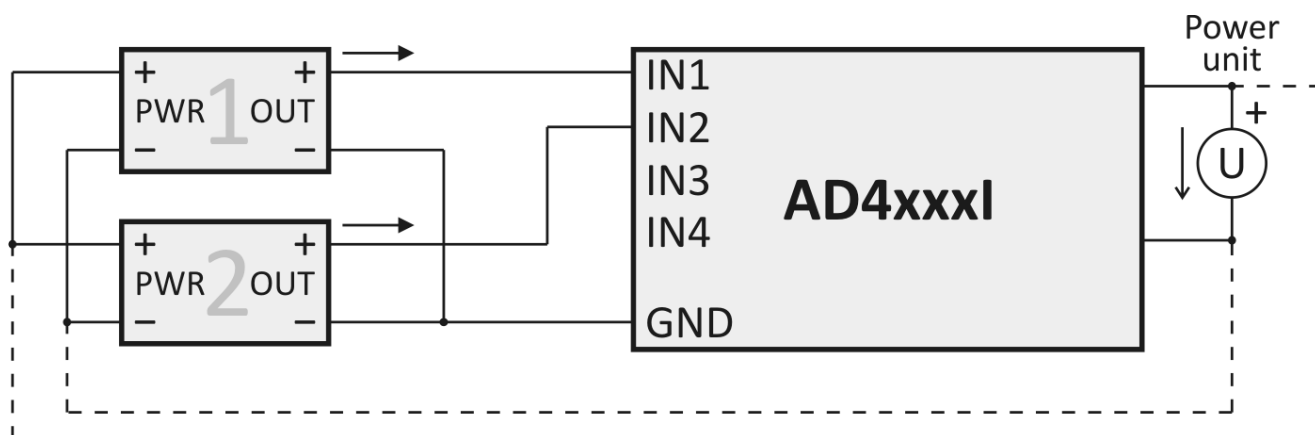

Fig. 5 – Current sensors with their own power supply

**Sensors with output of 0 to 20 mA, supplied through current loop****With a separate source for sensors**

In this case, the sensors are isolated from AD4ETH power supply.

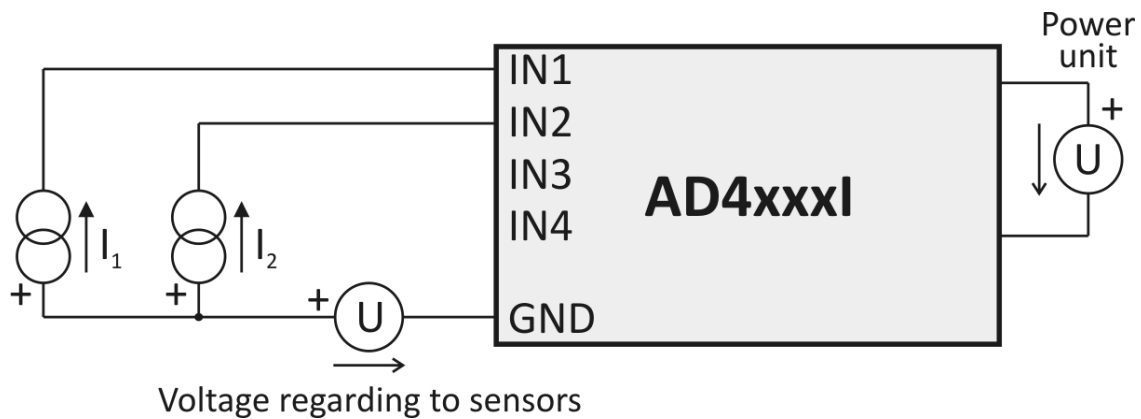

Fig. 6 – Current sensors with separate supply through current loop

**With a joint source for sensors and AD4ETH**

In this case, the sensors are isolated with AD4ETH power supply.

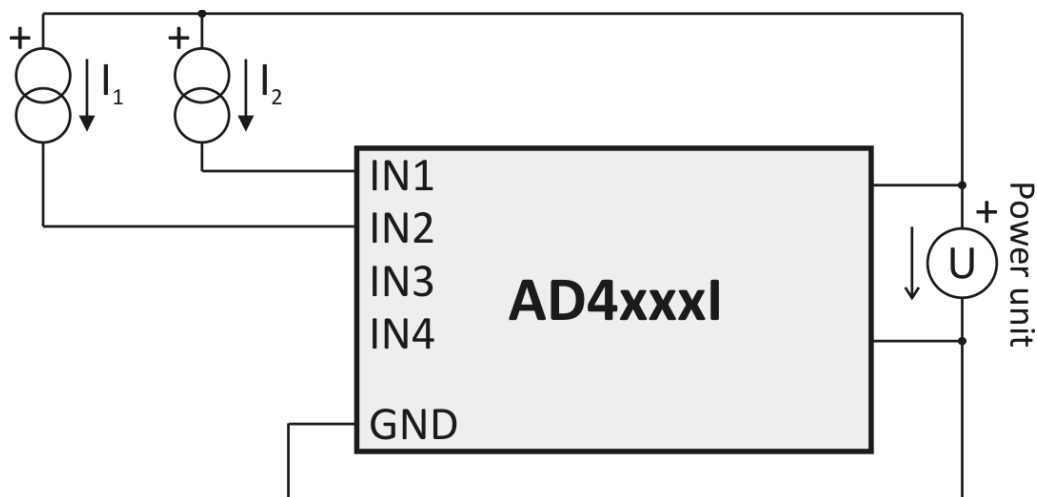

Fig. 7 – Current sensors supplied through current loop from joint source with AD4ETH

## WEB INTERFACE

It is possible to monitor the status of all inputs and to configure all parameters of the device via the WEB interface. WEB interface is available on the IP address of AD4ETH.<sup>3</sup> The initial IP address is 192.168.1.254.

The WEB page enables optical highlighting of the value exceeding the set limits or measuring errors (according to the setup, AD4ETH simultaneously sends an e-mail, SNMP trap etc.)

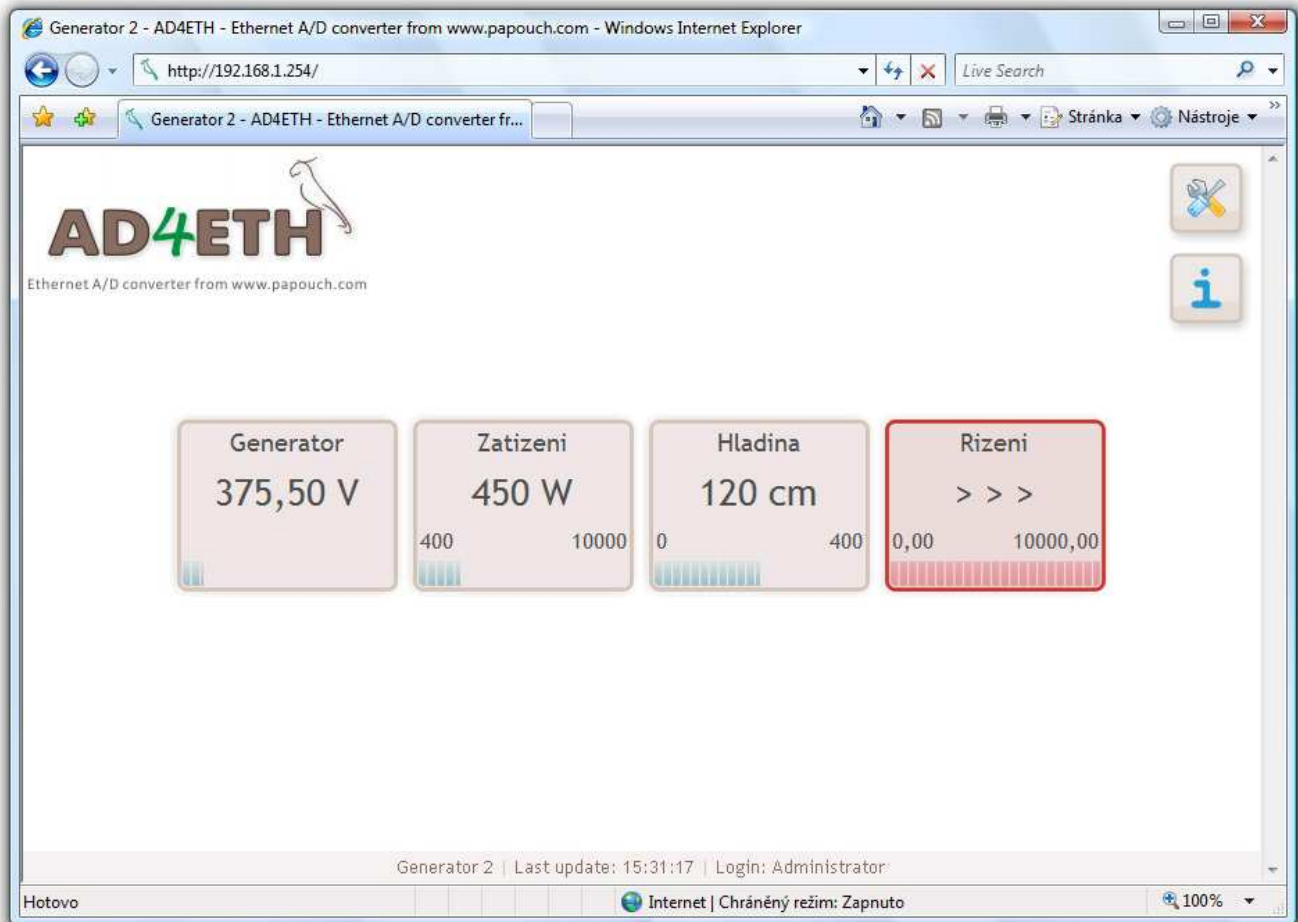

Fig. 8 – Example of WEB interface (three channels are all right, one shows range exceeding)

WEB interface is available in the Czech and English language.

The interface security is divided into two levels (each with an individual password). The “user” level only enables users to view the status of inputs. The “administrator” level also enables the configuration of the device.

Quick help for the individual setup items is displayed when you scroll the pointer of mouse over the appropriate input field.

AD4ETH enables the user to enter data (text or HTML) available from the main page. This option is suitable for entering instructions for the operating staff, providing a link to the company WEB, to other devices etc.

Configuration via the WEB interface is available by clicking on the symbol of the tool and is described in chapter [Configuration via WEB interface](#) beginning on page [26](#).

<sup>3</sup> The interface is optimized for the minimum resolution of 1024x768 pixels and for the browsers of Internet Explorer 6.0 and 7.0 and Firefox 2.0. It is necessary to enable JavaScript in the browser for the correct function of the interface.

## WAP

WAP interface allows monitoring of the current values from AD4ETH by means of a mobile phone, PDA or another mobile device. WAP is designed with minimum functionality with respect to the lowest possible data transmission.

WAP is available on the IP address of AD4ETH in the /wap folder. The initial setup of AD4ETH contains the following address of wap <http://192.168.1.254/wap> .

It is possible to update WAP automatically after a pre-defined interval. This interval can be set in the WEB setup in the Other settings tab. The default period is 30 sec.<sup>4</sup>

WAP is not secured, there is no user name or password required to access it. It is possible to restrict the display of the values on WAP in the WEB setup in the Security tab.



Fig. 9 – Example of WAP interface opened in a mobile device

<sup>4</sup> Periodical update is performed by the refresh meta tag. This method of update is not supported by all mobile devices.

## COMMUNICATION VIA TCP/UDP (SPINEL)

With AD4ETH it is possible to communicate via the TCP or UDP data channel using the Spinel protocol.

Communication protocol Spinel (binary and ASCII format) is described in a separate document including the examples, which is available for downloading from the AD4ETH WEB page on <http://www.papouch.com/>.

Spinel protocol communication is easy to test and tune with the program Spinel terminal which is available for the download on the address <http://spinel.papouch.com/>.

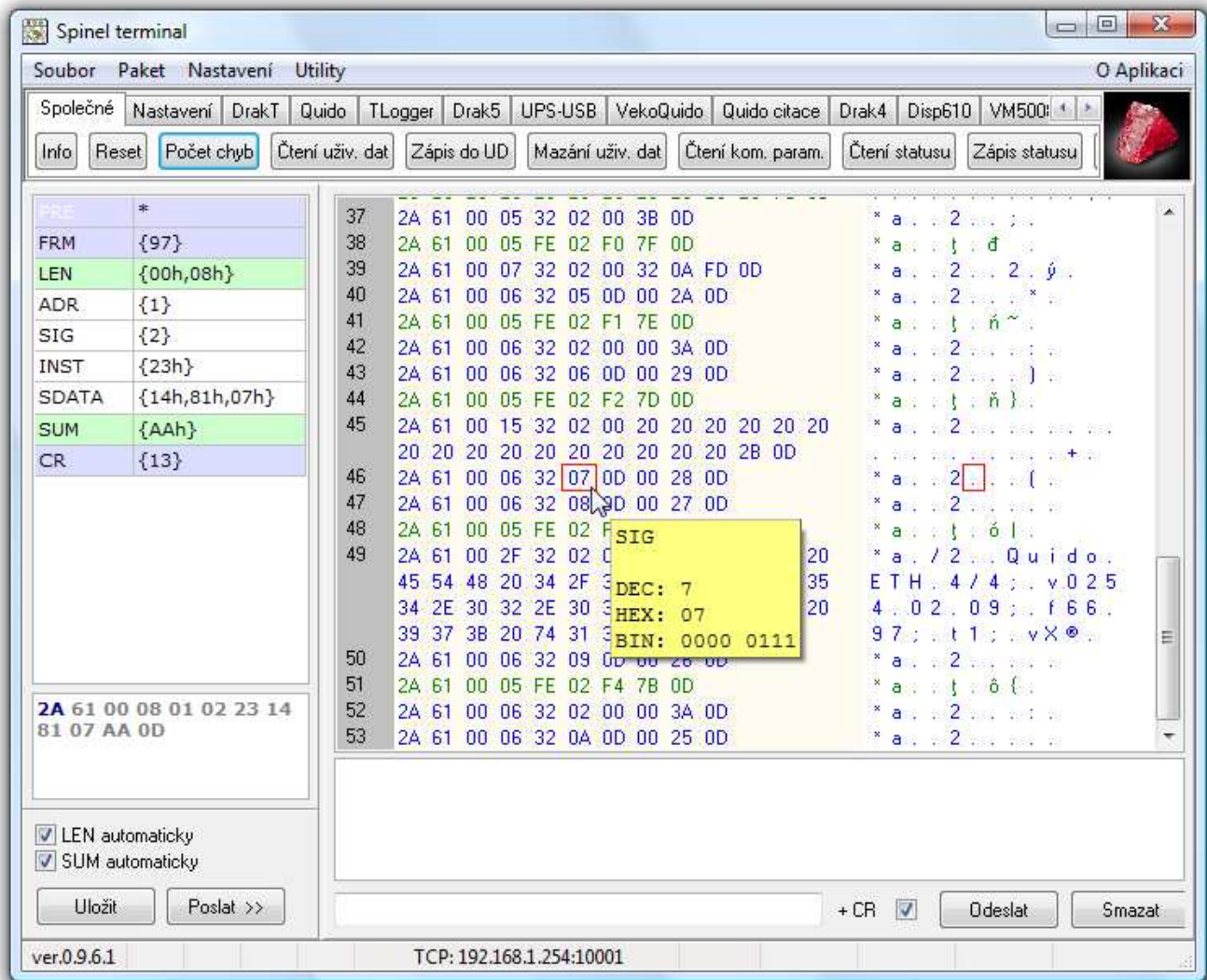

Fig. 10 – Example of the Spinel terminal program, tuning the communication with AD4ETH

AD4ETH allows the following types of data connection:

### TCP server

In the **TCP server** mode, AD4ETH expects the connection on the data port (set via the WEB interface in the [Local port](#) item). AD4ETH uses this TCP connection to communicate with a remote device by means of the Spinel protocol.<sup>5</sup>

<sup>5</sup> It is not possible to view the currently set values via the WEB in this mode and it is possible to perform only some settings via the WEB.

**TCP client**

---

In the **TCP client** mode, AD4ETH connects automatically to a remote IP address (set in the [Remote IP address](#)) a the port (set in the [Remote port](#)). AD4ETH uses this TCP connection to communicate with a remote device by means of the Spinel protocol.<sup>5</sup>

**UDP**

---

In the **UDP** mode, the data from AD4ETH is routed to a device with the IP address set in the [Remote IP address](#) item or, without routing, to a required address if the broadcast address of your network is set as the Remote IP address (a so called “UDP broadcast“). In this case, AD4ETH communicates with any device which asks.<sup>5</sup>

## CURRENT VALUES IN XML FORMAT

After the initialization of AD4ETH, it is possible to get current values in the XML format. The file with the values is available on the IP address of the device in the /data.xml file (the <http://192.168.1.254/data.xml> file for a device in the default configuration). This file is secured by means of a user name and password according to the setup via WEB.<sup>6</sup>

An example of the file with data in the xml format:

```
<?xml version="1.0" encoding="iso-8859-2"?>
<root xmlns="http://www.papouch.com/xml/ad4eth/actualvalues">
  <input id="1" unit="V" val="375,5" min="" max="" dot="2" bar="1000" stat="0" name="Generator" />
  <input id="2" unit="W" val="450" min="400" max="10000" dot="0" bar="2000" stat="0" name="Test" />
  <input id="3" unit="cm" val="120" min="0" max="400" dot="0" bar="5000" stat="0" name="Hladina" />
  <input id="4" unit="cm" val="73" min="0" max="10000" dot="2" bar="7000" stat="2" name="Rizeni" />
</root>
```

The meaning of individual parameters:

id..... channel number (1 to 4)

unit..... unit (user defined string with the unit)<sup>7</sup>

val..... measured value (decimal number recalculated according to the user defined range)<sup>8</sup>

min..... lower limit (decimal number or blank value if not pre-defined)<sup>9</sup>

max..... upper limit (decimal number or blank value if not pre-defined)<sup>10</sup>

dot..... number of decimal places the displayed values are to be rounded to (whole number ranging from 0 to 3 according to user setup)<sup>11</sup>

bar..... measured value as a number from the range of 0 to 10 000

name..... channel name (user defined string)<sup>12</sup>

stat..... measured value status. The status can be as follows:

<i>status</i>	<i>meaning</i>
0	Value is OK.
1	Value still not available.
2	Input range upper limit has been exceeded.
3	Input range lower limit has been exceeded. (applicable only for the input of 4 to 20 mA)
4	Measurement error. Invalid value.

<sup>6</sup> Basic HTTP authentication (HTTP 401).

<sup>7</sup> See the settings item named [Unit](#) on page [36](#).

<sup>8</sup> See the settings items named [Upper range limit](#) and [Lower range limit](#) on page [36](#).

<sup>9</sup> See the settings item named [Lower range limit](#) on page [36](#).

<sup>10</sup> See the settings item named [Upper range limit](#) on page [36](#).

<sup>11</sup> See the settings item named [Number of decimal places for math rounding](#) on page [36](#).

<sup>12</sup> See the settings item named [Channel name](#) on page [36](#).

## SENDING THE VALUES BY HTTP PROTOCOL (GET AND POST)

AD4ETH is able to send the measured values to a WEB server on the Internet or company intranet. The values are then easy to process using the common scripting language (PHP, ASP, .NET, ...), to display, store, analyze, etc.

Sending of the values works in the following way – the path to the server script is entered in the setup and AD4ETH sends the measured values to it in a pre-defined interval. It is possible to send values to the server from AD4ETH as a request of the HTTP GET or HTTP POST type (in the SOAP XML format).

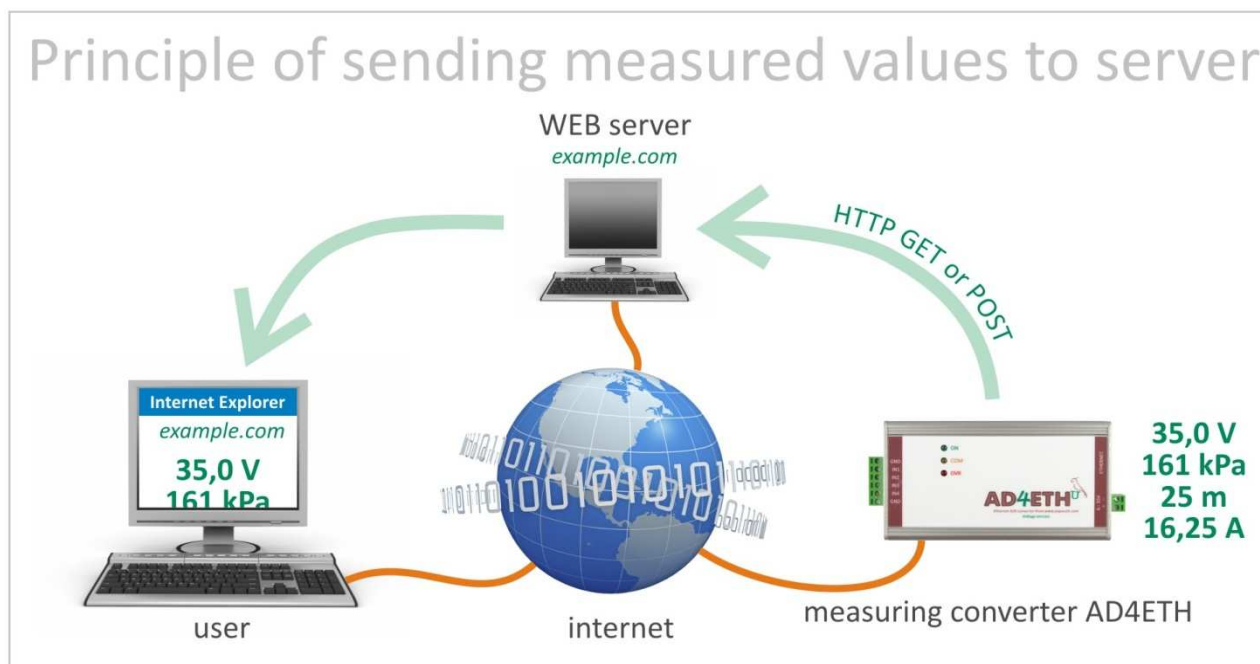

Fig. 11 – Principle of sending the measured values from AD4ETH to a WEB server on the Internet and then to User's Web browser

The setup of the sending process is performed in the [Sending](#) tab in the configuration via WEB. (AD4ETH is able to send either POST or GET, not both of them simultaneously.)

## HTTP GET

---

The HTTP GET request is sent separately for each channel. The the form of the request is illustrated in the following example:

```
../ad4.asp?ch=1&unit=V&val=375.50&min=&max=&stat=0&name=Generator&id=
```

As evident from the example, the request is in a form well-known to web programmers from the standard method of form data sending. It eliminates the necessity to learn new methods of programming and the processing can be handled by the mechanism known from web forms processing (<form name="myform" action=...).

The request is sent in an interval set in the [Sending period](#) item on page [34](#). Four requests are sent in the intervals, each with the values from one channel.

The parameters in GET are as follows:

ch..... channel number (1 to 4)

unit..... unit (user defined string with the unit)<sup>13</sup>

val..... measured value (decimal number recalculated according to the user defined range)<sup>14</sup>

min..... lower limit (decimal number or blank value if not pre-defined)<sup>15</sup>

max..... upper limit (decimal number or blank value if not pre-defined)<sup>16</sup>

stat..... measured value status. The status can be as follows:

<i>status</i>	<i>meaning</i>
0	Value is OK.
1	Value still not available.
2	Input range upper limit has been exceeded.
3	Input range lower limit has been exceeded. (applicable only for the input of 4 to 20 mA)
4	Measurement error. Invalid value.

name..... channel name (user defined string)<sup>17</sup>

id..... device identifier (user defined device identifier)<sup>18</sup>

<sup>13</sup> See the settings item named [Unit](#) on page [36](#).

<sup>14</sup> See the settings items named [Upper range limit](#) and [Lower range limit](#) on page [36](#).

<sup>15</sup> See the settings item named [Lower range limit](#) on page [36](#).

<sup>16</sup> See the settings item named [Upper range limit](#) on page [36](#).

<sup>17</sup> See the settings item named [Channel name](#) on page [36](#).

<sup>18</sup> See the settings item named [Device ID](#) on page [34](#).

## HTTP POST (SOAP)

The HTTP POST request is sent in an interval set in the [Sending period](#) item on the 34 in the form illustrated by the following example:

Header:

```
POST /ad4.asp HTTP/1.1
Host: www.example.com
Content-type: application/soap+xml; charset=iso-8859-2
Content-length: [the real length of the request body]
```

Request body:

```
<?xml version="1.0" encoding="iso-8859-2"?>
<soap12:Envelope xmlns:xsi="http://www.w3.org/2001/XMLSchema-instance"
xmlns:xsd="http://www.w3.org/2001/XMLSchema" xmlns:soap12="http://www.w3.org/2003/05/soap-
envelope">
  <soap12:Body>
    <root xmlns="http://www.papouch.com/xml/ad4eth/act">
      <input ch="1" stat="0" unit="" val="0" min="0.000" max="0.000" mode="0" name "---" />
      <input ch="2" stat="0" unit="" val="0" min="0.000" max="0.000" mode="2" name "---" />
      <input ch="3" stat="0" unit="" val="0" min="0.000" max="0.000" mode="1" name "---" />
      <input ch="4" stat="0" unit="" val="0" min="0.000" max="0.000" mode="1" name "---" />
    </root>
  </soap12:Body>
</soap12:Envelope>
```

Meaning of individual parameters:

ch ..... channel number (1 to 4)

stat .... measured value status. The status can be as follows:

<i>status</i>	<i>meaning</i>
0	Value is OK.
1	Value still not available.
2	Input range upper limit has been exceeded.
3	Input range lower limit has been exceeded. (applicable only for the input of 4 to 20 mA)
4	Measurement error. Invalid value.

unit .... unit (user defined string with the unit)<sup>19</sup>

val ..... measured value (decimal number recalculated according to the user defined range)<sup>20</sup>

min ..... lower limit (decimal number or blank value if not pre-defined)<sup>21</sup>

max ..... upper limit (decimal number or blank value if not pre-defined)<sup>22</sup>

<sup>19</sup> See the settings item named [Unit](#) on page [36](#).

<sup>20</sup> See the settings items named [Upper range limit](#) and [Lower range limit](#) on page [36](#).

<sup>21</sup> See the settings item named [Lower range limit](#) on page [36](#).

mode..... indicates whether the measured values monitoring is („1“) or is not („0“) switched on  
name..... channel name (user defined string)<sup>23</sup>

## INFORMATIVE E-MAILS SENDING

Based on the settings, AD4ETH is able to send e-mails informing the user that limits defined for individual channels have been exceeded. (Thanks to services provided by operators it is possible to forward the e-mail easily to a mobile phone as an SMS message.)

The e-mail can be sent to one address. The body of the e-mail contains information defining the channel in problem, showing the value that has been exceeded and the current value.

The emails can be set in the [E-mail](#) tab (see page [28](#)) in the WEB configuration. Here you can find the setup of the e-mail account as well as the SMTP server authorization (if required). The function of value monitoring can be set in the cards of individual channels the user wishes to monitor.

---

<sup>22</sup> See the settings item named [Upper range limit](#) on page [36](#).

<sup>23</sup> See the settings item named [Channel name](#) on page [36](#).

## SNMP PROTOCOL

(The version of AD4ETH with the SNMP protocol does not contain the MODBUS TCP protocol.)

(The version of AD4ETH with the MODBUS TCP protocol does not contain the SNMP protocol.)

The SNMP protocol is used in large companies for the centralized administration and monitoring of all hardware and technologies. AD4ETH is able to communicate via this protocol and, according to the setup, It sends SNMP traps when the pre-set critical limits are exceeded. It is also able to periodically send traps with current values.

A list of tables and their objects for the access over the SNMP protocol follows. SNMP parameters, including the address of SNMP client, can be [set](#) via the WEB interface in the Administrator mode.

### Analogue input name

---

**ID:** 1.3.6.1.4.1.18248.17.3.2.1.1.1.1 - 4

**Type:** String

**Action:** Read only

The object contains the current name of the pre-selected analog input.

### Analogue input status

---

**ID:** 1.3.6.1.4.1.18248.17.3.2.1.1.2.1 - 4

**Type:** Integer

**Action:** Read only

The object contains the channel status, representing the current status of the measured value in the following object. Options:

- 0 ... Value is up-to-date and valid
- 1 ... Value is not up-to-date or is not available
- 2 ... Upper limit exceeding
- 3 ... Lower limit exceeding (only for the range of 4 to 20 mA)
- 4 ... Measurement error

### Measured value

---

**ID:** 1.3.6.1.4.1.18248.17.3.2.1.1.3.1 - 4

**Type:** String

**Action:** Read only

The object contains the currently measured value form the pre-selected analogue input as a string.

### Units

---

**ID:** 1.3.6.1.4.1.18248.17.3.2.1.1.4.1 - 4

**Type:** String

**Action:** Read only

The object contains a string with the definition of units.

---

## Values monitoring

---

**ID:** 1.3.6.1.4.1.18248.17.3.3.1.1.1.1 - 4

**Type:** Integer

**Action:** Read only

The object contains the current status of the value monitoring function for a given channel.

Options:

0 ... Monitoring switched on

1 ... Monitoring switched off

---

## Upper limit

---

**ID:** 1.3.6.1.4.1.18248.17.3.3.1.1.2.1 - 4

**Type:** String

**Action:** Read only

Upper limit of the measured value. A trap is sent when the value is exceeded. (If the value monitoring function is switched on.)

---

## Lower limit

---

**ID:** 1.3.6.1.4.1.18248.17.3.3.1.1.3.1 - 4

**Type:** String

**Action:** Read only

Lower limit of the measured value. A trap is sent when a measuring result drops below this value. (If the value monitoring function is switched on.)

---

## Limits hysteresis

---

**ID:** 1.3.6.1.4.1.18248.17.3.3.1.1.4.1 - 4

**Type:** String

**Action:** Read only

A hysteresis value which shall apply below the upper and above the lower limit.

---

## Device name

---

**ID:** 1.3.6.1.4.1.18248.17.3.1.1.0

**Type:** String

**Action:** Read only

The object contains the device name.

---

## Trap text

---

**ID:** 1.3.6.1.4.1.18248.17.3.1.2.0

**Type:** String

**Action:** Read only

The object contains the text of the current trap.

## MODBUS PROTOCOL

(The version of AD4ETH with the SNMP protocol does not contain the MODBUS TCP protocol.)

(The version of AD4ETH with the MODBUS TCP protocol does not contain the SNMP protocol.)

MODBUS TCP is a standard industry protocol. AD4ETH is able communicate via this protocol. For complete information and documentation of the MODBUS TCP protocol see [www.modbus.org](http://www.modbus.org).

AD4ETH is able to use the 0x04 code, reading the input registers. The MODBUS enables the user to read the current status of all the four input channels including the just measured values.

The standard MODBUS port is 502. It can be changed via the WEB interface on the [MODBUS](#) tab.

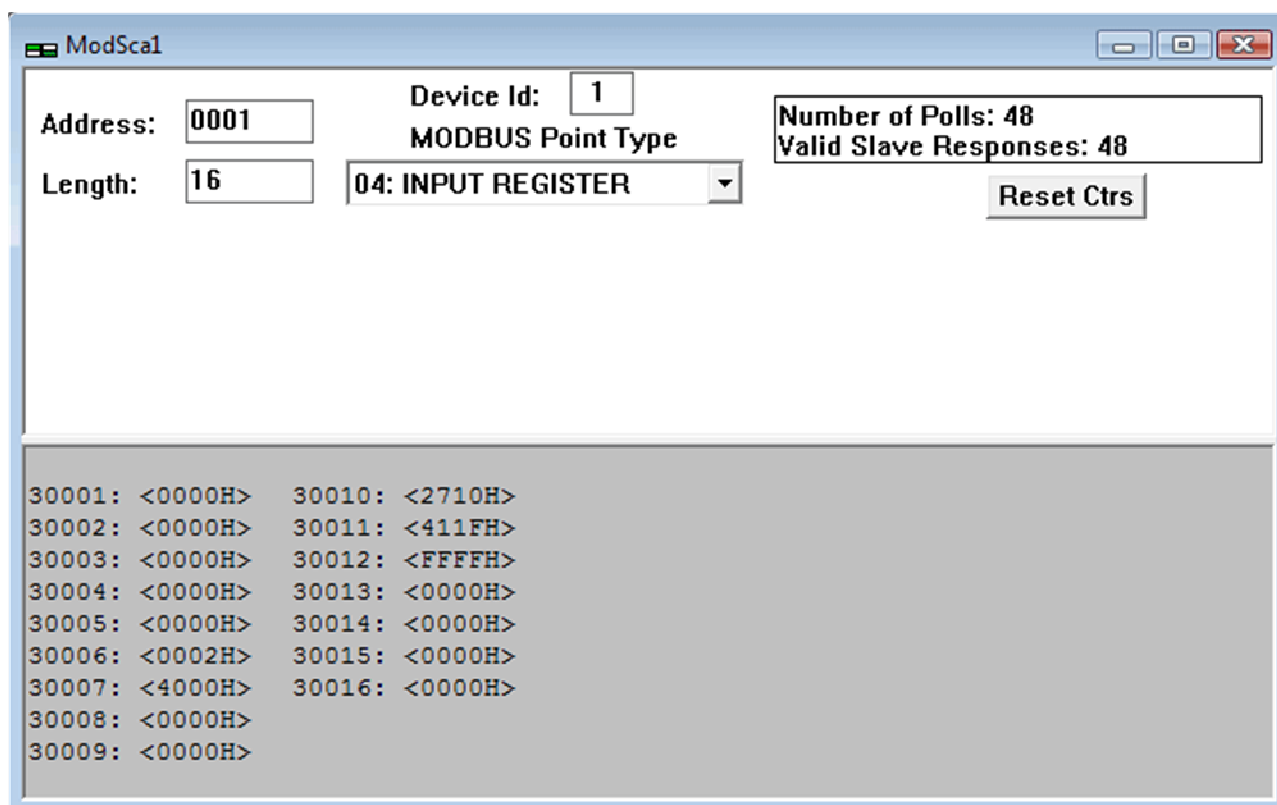

Fig. 12 – Example of the values of all registers read from AD4ETH by the MODBUS TCP protocol

## Current value reading

This is the way the system reads the last measured value from all or just some of the channels. It returns values in the form of whole numbers as well as decimal numbers (32bit float pursuant to IEEE 754).

The values are sent simultaneously in the two formats. The first one is the 16bit value within the range of 0 to 10 000 (integer in the order of MSB:LSB). The second one is a value recalculated for the current range based on the current setup as a decimal number in the 32 bit float format pursuant to IEEE 754<sup>24</sup>.

(The setup for value recalculation can be carried out via the WEB interface in the tab of the required channel. See [Upper range limit](#) and [Lower range limit](#) on page [36](#).)

### Enquiry:

Function code	1 Byte	0x04
Initial address	2 Bytes	channel 1: 0x0000 channel 2: 0x0004 channel 3: 0x0008 channel 4: 0x000C
No. of registers	2 Bytes	4

### Reply:

Function code	1 Byte	0x04
No. of bytes	1 Byte	8
Status	2 Byte	<i>0x0000</i> – valid value within the range <i>0x0001</i> – value not available yet <i>0x0002</i> – upper limit exceeding <i>0x0003</i> – lower limit exceeding (applicable only to the range of 4 to 20 mA) <i>Other values</i> – other errors
INT value	2 Byte	Measured value. Whole number ranging from 0 to 10 000
Float value	4 Byte	Measured value. 32 bit float pursuant to IEEE 754

### Error:

Function code	1 Byte	0x84 <sup>25</sup>
Error code	1 Byte	01 or 02 or 03 or 04

<sup>24</sup> For the description of the IEEE 754 standard see e.g.: [http://en.wikipedia.org/wiki/IEEE\\_754](http://en.wikipedia.org/wiki/IEEE_754)

<sup>25</sup> The complete description of error codes can be found in the original documentation of the MODBUS protocol on [www.modbus.org](http://www.modbus.org).

## KONFIGURACE

AD4ETH can be configured in the following ways:

- **WEB interface:** This interface is accessible from the IP address of the device. The default IP address is 192.168.1.254.
- **Telnet:** Telnet is accessible from the IP address of the device. The default setup is 192.168.1.254, port 9999. The description of Telnet can be found on page [37](#).

## CONFIGURATION VIA WEB INTERFACE

The WEB interface is accessible from the IP address of the device. The default IP address is 192.168.1.254. To enter the configuration click on the tool icon on the main page of the device (see the right picture).



(The interface is optimized for the resolution of at least 1024x768 pixels and for the Explorer 6.0 and 7.0 a Firefox 2.0 browsers)

This interface enables the user to monitor the status of all the inputs and to configure all the parameters of the device.

The interface security is divided into two levels (each with an individual password). The “user” level only enables users to view the status of inputs. The “administrator” level also enables the configuration of the device.

Quick help for the individual setup items is displayed when you scroll the pointer of mouse over the appropriate input field.

## Network

In this part it is possible to set network parameters, such as the IP address etc. including the communication mode. Any changes made in this part require the device to be restarted.

Network	E-mail	Security	SNMP	Sending	Other	Channel 1	Channel 2	Channel 3	Channel 4
<b>Network settings</b>									
IP address	<input type="text" value="192.168.1.254"/>								
Local port	<input type="text" value="10001"/>								
Netmask	<input type="text" value="255.255.255.0"/>								
Gateway IP	<input type="text" value="192.168.1.201"/>								
Remote IP address	<input type="text" value="19.16.13.221"/>								
Remote port	<input type="text" value="9999"/>								
WEB port	<input type="text" value="80"/>								
Communication mode	<input type="text" value="WEB (HTTP)"/>								
<input type="button" value="Save"/> <input type="button" value="Close"/>									

Fig. 13 – Network settings and communication mode configuration

**IP address**

*Default: 192.168.1.254*

The network address of AD4ETH. Enter the address in numbers separated by dots. The default address is [192.168.1.254](#).

**Local port**

*Default: 10001*

The data port on which AD4ETH expects the incoming TCP connection in the “TCP server” communication mode.

**Netmask**

*Default: 255.255.255.0*

Sets the netmask (the range of IP addresses used within the network segment) containing the AD4ETH. The netmask can also be expressed by means of letters. (A means 255.0.0.0; B means 255.255.0.0; C means 255.255.255.0)

**Gateway IP**

*Default: 0.0.0.0*

The IP address of the computer or router connecting the convertor with other (superior) networks and/or with the Internet. In case the convertor is located within an independent network or does not have an access to external networks, enter 0.0.0.0 as the address.

**Remote IP address**

*Default: 0.0.0.0*

The IP address of the device the convertor will connect to in the “TCP client” communication mode.

**Remote port**

*Default: 0*

The port of the remote device the convertor will connect to in the “TCP client” communication mode.

**WEB port**

*Default: 80*

Here, it is possible to change the default value of the port enabling the access to the WEB site. This option is suitable in case AD4ETH is located behind a firewall or a router with blocked port 80 (standard WEB port). If this is the case, find an unoccupied port to be set as the WEB port. The WEB site will be then accessible from the browser after entering the address in the form of [http://\[IP-adresa\]:\[port\]](http://[IP-adresa]:[port]) For example: <http://192.168.1.254:8080> port 8080.

**Communication mode**

*Default: WEB (HTTP)*

Tato volba nastavuje typ komunikace AD4ETH. Jsou k dispozici tyto módy: TCP server, TCP client, UDP a WEB (HTTP).

In the **TCP server** mode, AD4ETH expects the connection on the data port (set via the WEB interface in the [Local port](#) item). AD4ETH uses this TCP connection to communicate with a remote device by means of the Spinel protocol. It is not possible to view the currently set values via the WEB in this mode and it is possible to perform only some settings via the WEB.

**Warning:** This mode does not enable the user to use options configurable in the [E-mail](#), [SNMP](#), [MODBUS](#), [Sending](#) and [Channel](#) tabs.

In the **TCP client** mode, AD4ETH connects automatically to a remote IP address (set in the [Remote IP address](#)) a the port (set in the [Remote port](#)). AD4ETH uses this TCP connection to communicate with a remote device by means of the Spinel protocol. It is not possible to view the

currently set values via the WEB in this mode and it is possible to perform only some settings via the WEB.

**Warning:** This mode does not enable the user to use options configurable in the [E-mail](#), [SNMP](#), [MODBUS](#), [Sending](#) and [Channel](#) tabs.

In the **UDP** mode, the data from AD4ETH is routed to a device with the IP address set in the [Remote IP address](#) item or, without routing, to a required address if the broadcast address of your network is set as the Remote IP address (a so called “UDP broadcast”). In this case, AD4ETH communicates with any device which asks. It is not possible to view the currently set values via the WEB in this mode and it is possible to perform only some settings via the WEB.

**Warning:** This mode does not enable the user to use options configurable in the [E-mail](#), [SNMP](#), [MODBUS](#), [Sending](#) and [Channel](#) tabs.

Device isn't in WEB mode. On-line view of measurement values is available only in WEB mode. This mode could be set in folder Network.

Fig. 14 – Current values display is not available in the TCP server, TCP client and UDP modes as well as the options configurable in the [E-mail](#), [SNMP](#), [MODBUS](#), [Sending](#) and [Channel](#) tabs

The **WEB (HTTP)** mode enables the user to monitor the currently measured values via the WEB interface, to send the measured values in the HTTP GET or POST formats (SOAP XML) and to communicate via the SNMP protocol. This mode also enables AD4ETH to inform the user via email about any occurrence of critical limits exceeding.

## E-mail

This part configures the email account used by AD4ETH as well as the email address to which emails about critical limits exceeding shall be sent.

Network	E-mail	Security	SNMP	Sending	Other	Channel 1	Channel 2	Channel 3	Channel 4
<b>E-mail settings</b>									
Activate e-mail sending									<input checked="" type="checkbox"/>
SMTP server IP address						<input type="text" value="123.123.123.123"/>			
E-mail address of this device						<input type="text" value="ad4@example.net"/>			
Recipient E-mail address						<input type="text" value="mailbox@example.com"/>			
<b>SMTP authorization</b>									
SMTP server require authorization									<input checked="" type="checkbox"/>
Name						<input type="text" value="mailbox"/>			
Password						<input type="password" value="*****"/>			
Retype password						<input type="password" value="*****"/>			
<b>Test of settings</b>									
After saving configuration, device will send information e-mail									<input type="checkbox"/>
						<input type="button" value="Save"/>		<input type="button" value="Close"/>	

Fig. 15 – Emails configuration

**Activate e-mail sending**

*Default: Disabled*

By ticking this field you will activate the function of channel critical level monitoring. The emails will be sent if the monitoring function is switched on and set for individual channels in the relevant tabs.

**SMTP server IP address**

*Default: 0.0.0.0*

The IP address of the SMTP server for outgoing mail.

**E-mail address of this device**

*Default: (Nothing)*

The email address of AD4ETH. Any email address can be entered here (even a nonexistent one). This address will be shown in the sent email as sender's address.

**Recipient E-mail address**

*Default: (Nothing)*

Recipient's email address. Here enter the email address which you wish the information about limits exceeding to be sent to.

**SMTP server require authorization**

*Default: Disabled*

Tick this field and fill in the three fields below if the SMTP entered in the [SMTP server IP address](#) requires the authorization of user identification (used as a protection against SPAM sending).

**Name**

*Default: (Nothing)*

Name for the authorization on the SMTP server.

**Password****Retype password**

*Default: (Nothing)*

Password for the authorization on the SMTP server.

**After saving configuration, device will send information e-mail**

*Default: Disabled (cannot be changed)*

If this field is ticked during the configuration saving, the device will send a testing e-mail to the entered address in order to verify that the configuration has been done as required.

## Security

The WEB interface security is set here. The security consists of two levels. Both levels have a common user name but different passwords. The lower “User” level only enables the user to view the measured values. The “administrator” level also enables the configuration of the device. Any changes made in this part require the device to be restarted.

Fig. 16 – Security Settings

### Name for administrator and user

*Default: (Nothing)*

The administrator and user have a common field for entering the name. The name together with the relevant password is required to be entered into the system during opening the relevant WEB page.

### Allow WAP pages

*Default: Enabled*

This tick enables the values to be viewed via the WAP interface (accessible at [http://\[ip-address\]/wap](http://[ip-address]/wap) ).

The option for WAP enabling or disabling is here because the WAP interface is always unsecured and no password is required to access it.

### New user password

### Retype new user password

*Default: (Nothing)*

User's password.

### New administrator password

### Retype new administrator password

*Default: (Nothing)*

Administrator's password.

## Check rights authorization

*Default: (Nothing)*

Whenever there is made any change to the security settings, the system requires the user to enter the relevant administrator password.

## SNMP

This part sets the parameters for the communication via SNMP.

(This tab is not available in the version with MODBUS protocol)

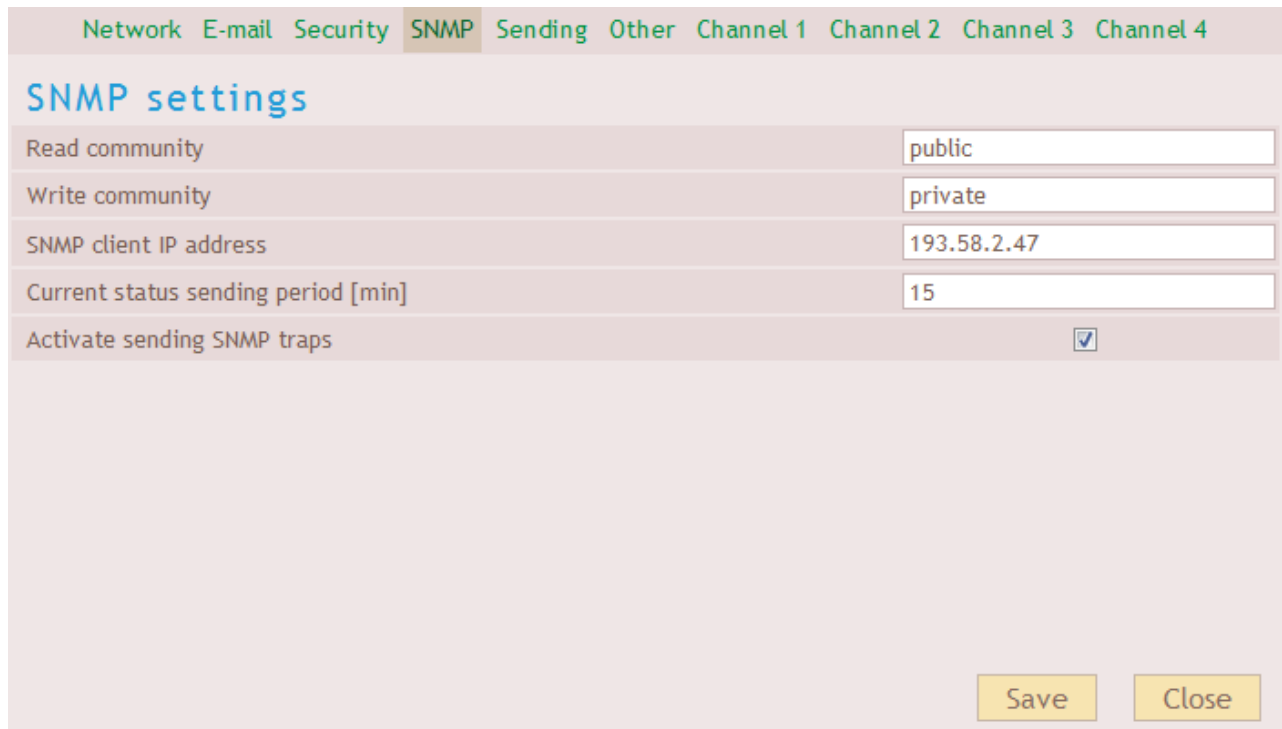

Read community	public
Write community	private
SNMP client IP address	193.58.2.47
Current status sending period [min]	15
Activate sending SNMP traps	<input checked="" type="checkbox"/>

Fig. 17 – SNMP Settings

### Read community

*Default: public*

The name of the SNMP community for reading.

### Write community

*Default: private*

The name of the SNMP community for writing.

### SNMP client IP address

*Default: 0.0.0.0*

The IP address of the SNMP manager which the traps (automatic messages) are sent to.

### Current status sending period

*Default: 0*

If a number higher than 0 is entered, a trap with the currently measured values is sent in the set interval. The interval can be set in whole minutes ranging up to 3600 minutes.

### Activate sending SNMP traps

*Default: Disabled*

Global activation of the automatic messages (traps) sending via the SNMP protocol.

## MODBUS

This part sets the parameters for the communication via MODBUS TCP. Any changes made in this part require the device to be restarted.

(This tab is not available in the version with SNMP protocol.)

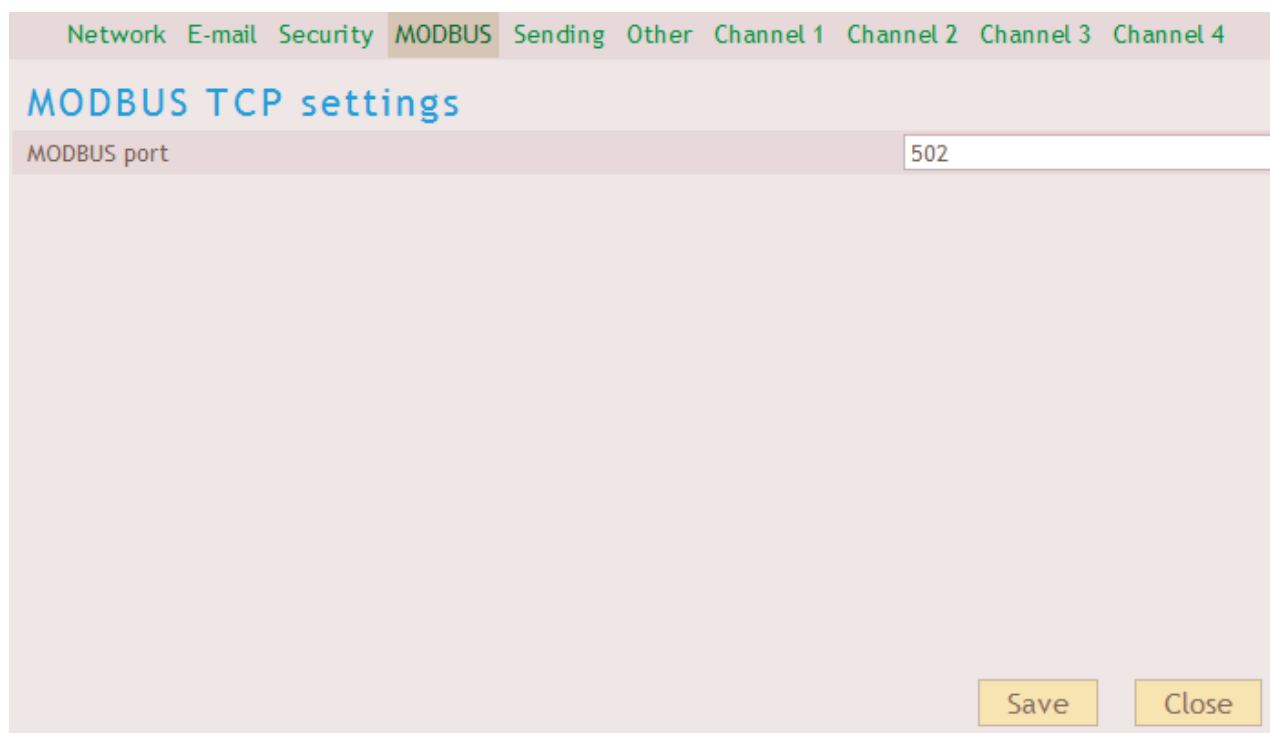

Network E-mail Security MODBUS Sending Other Channel 1 Channel 2 Channel 3 Channel 4

### MODBUS TCP settings

MODBUS port

Save Close

Fig. 18 – MODBUS Settings

### MODBUS port

Default: 502

The number of the port on which the device communicates with the surroundings via the MODBUS TCP protocol.

## Sending

Here it is possible to set the automatic sending of the measured values to the WEB server as a request of the HTTP GET or HTTP POST type in the SOAP XML format.

Fig. 19 – Settings for values sending to the WEB server

### Method of sending

Default: HTTP GET

AD4ETH is able to send the measured values as a request HTTP GET or HTTP POST request (SOAP XML). Detailed information about these methods can be found in chapter [Sending the values by HTTP protocol \(GET and Post\)](#).

### URL address of server

Default: (Nothing)

Here enter the URL address of the WEB server to which the measured values are to be sent. The address shall be set in the format: *www.example.com*.

### Local address of script

Default: (Nothing)

Here enter the local address of the script on the server. For example, if your server contains the “scripts” directory with the ad4.asp file intended for the processing of the measured values, enter the */scripts/ad4.asp* text into the field.

### IP address of server

Default: 0.0.0.0

Here enter the IP address of the WEB server (the IP address of the server entered in the [URL address of server](#) field).

### Server port

Default: 80

Port number on the WEB server.

## Sending period

Default: 0

The interval in which the measured values are to be sent. It is possible to set an interval ranging from 10 seconds to 1 hour. If the interval is set to 0, the sending function is switched off.

## Device ID

Default: (Nothing)

Device ID is a string on any characters which is included into GET as an *id* parameter. It can be used for identification etc.

## Other

Here it is possible to set some other parameters of the device.

Network E-mail Security MODBUS Sending Other Channel 1 Channel 2 Channel 3 Channel 4

### Other settings

Language English

Device name My AD4

WAP page refreshing period 30

Minimize main page

Field for user informations Used: 11 %

User defined informations (text or HTML)

Save Close

Fig. 20 – Other Settings

## Language

Default: English

This option contains a list of WEB interface language version. Currently, the WEB interface is available in Czech and English languages. Only some of the texts change after selecting the other language and saving the settings. For complete change of all the texts it is necessary to reopen the page.

## Device name

Default: AD4ETH

Here it is possible to allocate a name to the device. The name can enable the user to easily identify e.g. the measuring point etc.

## WAP page refreshing period

Default: 30

Here it is possible to define the interval of the WAP page refreshing. If the value is set to 0, the page does not refresh automatically and the displayed content needs to be refreshed manually by reopening the page. (Automatic refreshing is performed by the meta-refresh tag. This method is not supported by all mobile phones.)

## Minimize main page

*Default: Disabled*

If this field is ticked, the page size in the browser is automatically reduced to the smallest possible displaying size. This change of the size becomes effective only after the page is reopened in the browser.

## Field for user informations

*Default: (Empty)*

This field is available for entering a text or HTML code which is displayed after clicking on the **i** symbol on the main page. This can be used for entering links to the company website or to the intranet, measuring instructions etc.

## Channel

Here you can set measuring parameters separately for each channel. The standard output from AD4ETH is a value ranging from 0 to 10 000. AD4ETH is able to recalculate this range into another one according to user setup. For example, if a pressure sensor is connected, it is possible to enter its output range and AD4ETH will directly display the measured value recalculated for example in Pascals. (See the example bellows the figure.)

The input range given by the AD4ETH hardware is displayed next to the channel number.

Network E-mail Security MODBUS Sending Other Channel 1 Channel 2 Channel 3 Channel 4

**Channel 1** (Input range: 0 - 10V)

Channel name	Pressure sensor
Unit	kPa
Upper range limit	100
Lower range limit	0
Number of decimal places for math rounding	1
<b>Monitoring of measurement value</b>	
Monitoring of measurement value	<input checked="" type="checkbox"/>
Upper limit	80
Lower limit	60
Hysteresis	3

Save Close

Fig. 21 – Setup of the measuring input parameters

**Example:** The pressure sensor with the output of 0 to 10 V is connected to AD4ETH. The sensor measures the pressure in the range of 0 to 100 kPa with the accuracy of 0,1 kPa. Enter 100 into the [Upper range limit](#) field (because 10 V from the sensor stands for 100 kPa). Enter 0 to the [Lower range limit](#) field (because the sensor measures from 0 kPa). Enter 1 into the [Number of decimal places for math rounding](#) field (because the sensor measures with the accuracy of 0,1 kPa). Enter kPa into the [Unit](#) field (because the output shall be in kilo Pascals). AD4ETH will then display values within the range 0,0 to 100,0 kPa.

**Channel name***Default: ---*

Text description of the input.

**4-20mA sensor connected to input***Default: Disabled*

(This setting is visible only for the channel with the current range of 0 to 20 mA.) Tick the box only in the case that a sensor with the range of 4 to 20 mA is connected to this current input. AD4ETH will choose another mechanism of the recalculation which will allow using the whole resolution of the converter and also detecting the disconnection of the sensor (or value dropping below the range).

The screenshot shows a configuration window for Channel 3. At the top, there are tabs for Network, E-mail, Security, MODBUS, Sending, Other, Channel 1, Channel 2, Channel 3 (selected), and Channel 4. Below the tabs, the title is 'Channel 3 (Input range: 0 - 20mA)'. There are three input fields: 'Channel name' with the value 'Water level', '4-20mA sensor connected to input' with a checked checkbox, and 'Unit' with the value 'm'.

Fig. 22 – Channel with the current input range contains an additional field for the selection of the sensor output range

**Warning:** When the channel is switched to “4 to 20 mA”, AD4ETH indicates not only exceeding the upper but also value dropping below the lower limit if the current is lower than 4 mA. It means that the drop is indicated also when the sensor is not connected. (Because the current is null.)

**Unit***Default: (Nothing)*

Enter here the text description of the unit which is the output of the recalculation specified in the following fields.

**Upper range limit***Default: 10000*

Enter the positive real number as the upper range limit, corresponding to the maximum input range.

**Lower range limit***Default: 0*

Enter the positive real number as the lower range limit, corresponding to the minimum input range.

**Number of decimal places for math rounding***Default: 0*

Enter the number of decimal places for math rounding of the measured value.

**Monitoring of measurement value***Default: Disabled*

It is possible to switch on the monitoring of measured values from this channel. If the measured value either exceeds the Upper range limit or drops-off below the Lower range limit, the information about it is sent via e-mail, SNMP, ... (according to the setup).

**Upper limit***Default: 0*

Enter the maximum acceptable value. This value exceeding will cause the sending of the information via e-mail, SNMP, etc. according to the setup.

**Lower limit***Default: 0*

Enter the minimum acceptable value. This value dropping-off will cause the sending of the information via e-mail, SNMP, etc. according to the setup.

**Hysteresis***Default: 0*

Enter the hysteresis value which will apply below the Upper range limit and above the Lower range limit. (The term hysteresis is explained in the attachment of the document "Communication protocol Spinel", downloadable from [www.papouch.com](http://www.papouch.com) in the section dedicated to AD4ETH.)

## BASIC SETUP VIA TELNET

### Connection

#### IP address is not known

- 1) Open the window of the cmd. command (In OS Windows choose Start/Run, enter `cmd` into the provided line and press Enter.)
- 2) Make the following entry into the ARP chart:
  - a. Enter `arp -d` and confirm by Enter. This will delete the current ARP table.
  - b. Use the following command to allocate an IP address to the module MAC address:  
`arp -s [new_ip_address] [MAC_address_AD4ETH]`  
example: `arp -s 192.168.1.254 00-20-4a-80-65-6e`
- 3) Now open Telnet. (By typing in `telnet` and pressing Enter.<sup>26</sup>)
- 4) Type `open [new_ip_address] 1` and confirm.
- 5) The terminal will display an error message informing the user that no connection has been established. Still it is necessary to carry out the aforesaid in order to enable the module to enter the required IP address into the ARP table.
- 6) Connect to the module IP address. (Enter `open [IP address in the dotted format] 9999` and press Enter.)
- 7) So far you only managed to enter the module configuration. The IP address has not been set yet. It must be set using the relevant item in the Server Configuration > IP Address menu. If the configuration is closed without saving the setup and IP address configuration, it is necessary to repeat the whole process!
- 8) If the IP address is valid, the device will display introductory information ending with the following text:  
**Press Enter for Setup Mode**  
Now it is necessary to press Enter within three seconds, otherwise the configuration will be closed.
- 9) The device will display its complete setup.
- 10) At the end of the list there is a section called "Change setup:" providing a list of parameter groups which can be set. Changes to network parameters can be made through the "Server" section.

---

<sup>26</sup> In OS Windows Vista, the client for Telnet is not a standard part of the system. Install it using the following procedure:

- a) Open the "Control Panels/Programs and Features" menu.
- b) On the left, click "Enable or disable features of Windows system " (this option requires the administrator to log in).
- c) The "Features of Windows system" window displays. Here tick the "Telnet service Client" field and click Ok. The client for Telnet will be installed.

## IP address is known

- 1) In OS Windows choose Start/Run, enter `telnet` in the provided line and press Enter.<sup>26</sup>
- 2) Connect to the module IP address. (Enter `open [IP address in the dotted format] 9999` and press Enter.)
- 3) If the IP address is valid, the device will display introductory information ending with the following text:
 

```
Press Enter for Setup Mode
```

Now it is necessary to press Enter within three seconds, otherwise the configuration will be closed.
- 4) The device will display its complete setup.
- 5) At the end of the list there is a section called "Change setup:" providing a list of parameter groups which can be set. Changes to network parameters can be made through the "Server" section.

## Main Menu

Individual menu items can be chosen using the numbers written in front of them. Choose the required number and press Enter.

The menu structure is as follows:

```
Change Setup:
  0 Server
  ...
  7 Defaults
  8 Exit without save
  9 Save and exit          Your choice ?
```

## Server

Basic Ethernet setups.

The following items can be found in this part:

```
IP Address : (192) .(168) .(001) .(122)
Set Gateway IP Address (N) ?
Netmask: Number of Bits for Host Part (0=default) (16)
Change telnet config password (N) ?
```

### IP Address

IP address of the module. The numbers of the IP address shall be entered individually and separated by Enter.

Default value: 192.168.1.254

### Set Gateway IP Address

#### Gateway IP address

In the "Set Gateway IP Address" item enter "Y" to change the Gateway IP address. The system then invites you to change the Gateway IP address. The numbers of the IP address shall be entered individually and separated by Enter.

**Netmask**

Here you can set the number of bits of the IP address constituting the network part.

The Netmask is set as a number of bits determining the range of possible local network IP addresses. For example, if the value 2 is entered, the Netmask has the following structure 255.255.255.252. The entered value specifies the number of bits from the right. The maximum is 32.

Default value: 8

Example:

The mask 255.255.255.0 (binary 11111111 11111111 11111111 00000000) corresponds to number 8.

The mask 255.255.255.252 (binary 11111111 11111111 11111111 11111100) corresponds to number 2.

**Change telnet config password****Enter new Password**

This item can be used to set a new password which is required before any configuration is made via telnet or WEB interface.

In item "Change telnet config password" enter "Y" to change the password. The system then invites you to change the password.

**Factory Defaults**

By pressing number 7 the device restores the default setting.

Default setting means that the IP address is set to 192.168.1.254, all passwords are cancelled, names and parameters are deleted.

**Exit without save**

Closing the setting mode without saving the changed parameters.

**Save and exit**

This option saves the changes. If any parameter has been changed, the device is then restarted. The restart takes several tens of seconds.

## IP ADDRESS CHANGE

The IP address can be changed by one of the following methods:

- over the WEB interface
- using a universal software<sup>27</sup>
- via the ARP protocol and Telnet

The **WEB interface** can be unavailable during the first connection if the initial IP address is not compatible with the network the AD4ETH device is connected to. In this case, the IP address can be set using the Universal Software or via the ARP protocol and Telnet.

The setup **via the ARP protocol and Telnet** is described in the chapter [Basic Setup via Telnet](#) on page [38](#).

### Universal Software

This software can be used for the setup of basic network parameters. After running the software click on the “Set IP” button.

This command enables you allocate a new IP address to the device. After clicking the button, the window shown in Figure 3 displays. Enter the MAC address of the Battery monitor and click “Next”.

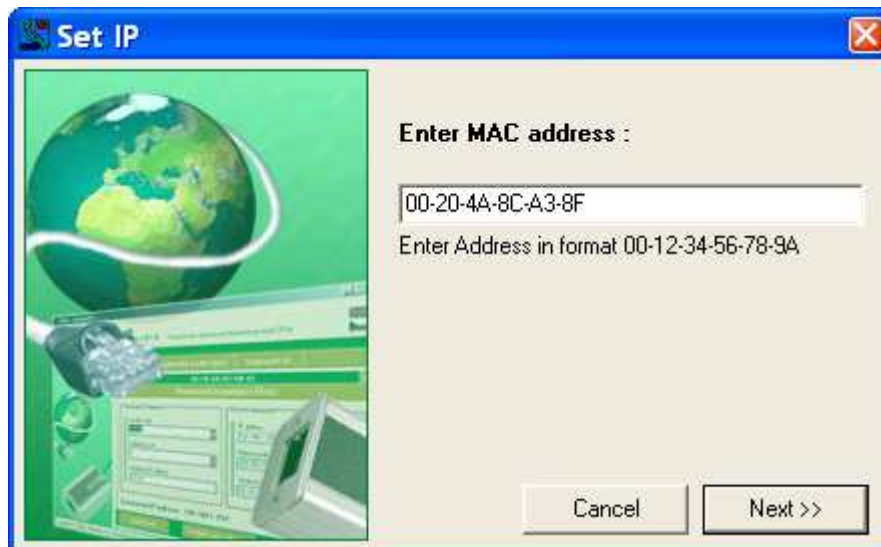

Fig. 23 – the first window of the guide for a new IP setup

Now the relevant MAC address is searched. If it is found, the window shown in Figure 5 displays. If it is not found, the warning shown in Figure 4 displays.

<sup>27</sup> This software can be downloaded from [www.papouch.com](http://www.papouch.com).

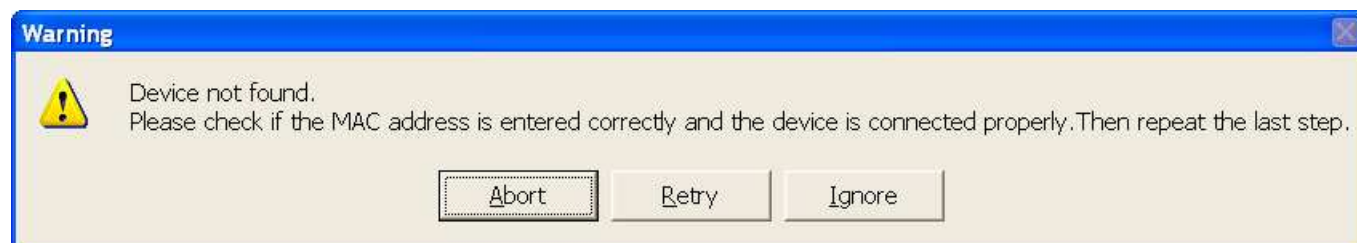

fig. 24 – the entered address has not been found

Choose “**Abort**” here, which will enable you to continue with the guide even though the MAC address has not been found.

Enter all parameters complying with your network into the window shown in Figure 5. If you are not sure which values need to be filled in, contact your network administrator, who will allocate you the required values. The parameters will be changed by clicking the “Set up” button.

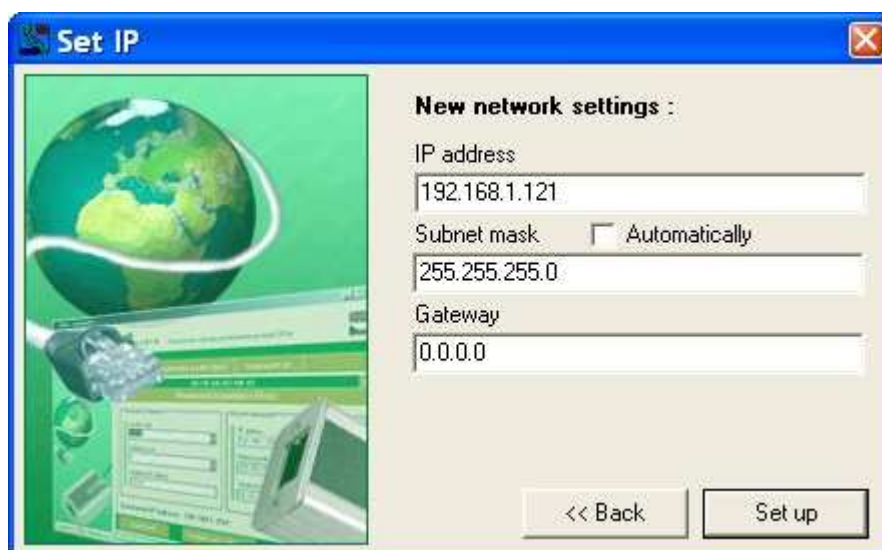

Fig. 25 –IP setup guide > setting of IP, mask and gateway

If the MAC address has not been found in the network, the dialogue shown in Figure 6 displays.

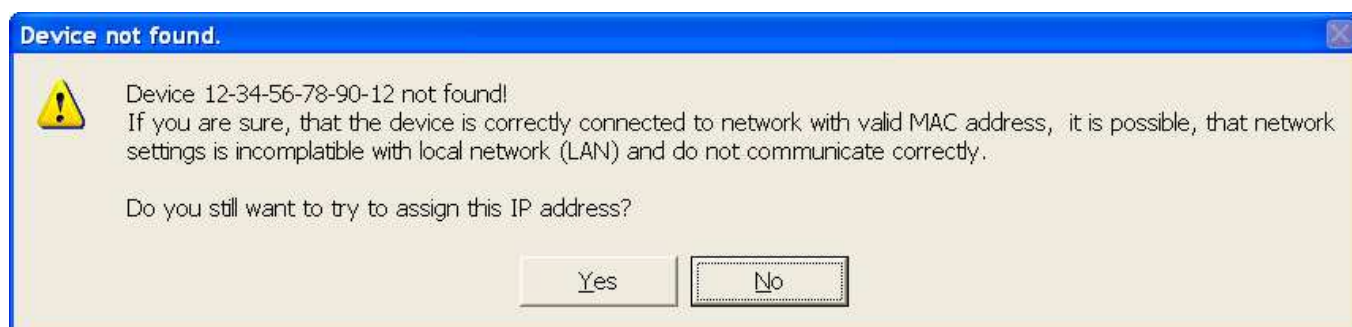

fig. 26 – MAC address has not been found

If you are sure the device is property connected to the network and the MAC address has been entered correctly, click “Yes”. The program will try to send a command for network parameters reconfiguration to the entered MAC address. A window informing the user whether the setting has been made successfully or not will appear in a little while.

If yes, the network parameters are now set as required and it is possible to make a connection via the WEB browser.

## TECHNICAL PARAMETERS

### Analogous inputs:

Number of inputs .....	4
Input type.....	unipolar
Voltage input range .....	0 – 10 V; 10 000 divisions
Current input ranges.....	0 – 20 mA; 4 – 20mA; 10 000 divisions
Calibration .....	10 000 divisions/range
A/D converter resolution .....	16 bits
Maximum non-linearity.....	10 divisions
Maximum zero error .....	10 divisions
Maximum rang error .....	10 divisions
Maximum measuring speed.....	406 ms (all channels)
Calibration method .....	software <sup>28</sup>

### Control interface:

Type.....	10/100 Ethernet
Connector .....	RJ45
Communication speed.....	115 200 Bd
Communication protocol.....	Spinel, TCP/IP, UDP/IP, HTTP

### Power supply:

Supply voltage .....	DC 6 to 35 V (with polarity reversal protection)
Power consumption .....	usually 170 mA at 12 V

### Other parameters:

Operation temperature.....	-20 °C to +70 °C
Dimensions.....	104 mm x 55 mm x 24 mm
Dimensions incl. connectors.....	121 mm x 55 mm x 24 mm
Dimensions incl. DIN rail holder.....	104 mm x 55 mm x 33 mm
Weight .....	140 g

<sup>28</sup> Calibration is described in greater detail in the communication protocol description which is available to be downloaded from the device web page.

## Available Designs

---

### Assembly:

- Without a holder (*standard design*)
- With a DIN rail holder



Fig. 27 - AD4ETH with DIN rail holder

- With a wall holder



Fig. 28 – AD4 with wall holder

### Input ranges:

- 0 to 10 V
- 0 to 20 mA
- 4 to 20 mA
- It is possible to deliver another current or voltage range upon request; it is also possible to combine more ranges in one device

Do not hesitate to contact us in case of any other special requirements concerning the AD4ETH module design and functions.

## INDICATIONS

The device contains three light indicators showing the operational status:

### ON

Green light. Lights when the supply voltage is connected.

### COM

Yellow indicator. Blinks once after initialization sequence. Then it is flashing during the communication over Ethernet and in WEB communication mode.

### OVR

Red light. Flashes repeatedly when the input range of any channel has been exceeded.

Warning: When the channel is switched to “4 to 20 mA” range, AD4 indicates not only exceeding the upper limit, but also value dropping below the lower limit if the current is lower than 4 mA. It means that the drop is indicated also when no sensor is connected (because the current is zero).

