

# ***TFT-Display Datenblatt***

Modell LB043WQ4-TD01

## **Kurzdaten**

Hersteller	LG Display
Diagonale	4,3" / 10,9 cm
Format	16:9
Auflösung	480 x 272
Backlight	LED / 400 cd/m <sup>2</sup>
Interface	TTL
Touchscreen	nein
Temperatur	-30...+85°C (Betrieb)

**Product Specifications**

# SPECIFICATION FOR APPROVAL



Inselkammerstr. 10  
82008 Unterhaching  
Tel: +49 89 614 503 40  
www.hy-line.de/computer

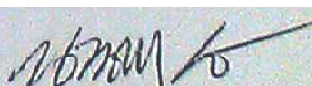


- ( ) Preliminary Specification
- (●) Final Specification

<b>Title</b>	<b>4.3"WqVGA (480 X RGB X 272) TFT - LCD</b>
--------------	--

BUYER	
MODEL	

SUPPLIER	LG Display Co., Ltd.
MODEL	LB043WQ4
SUFFIX	TD01

SIGNATURE	DATE
/	_____
/	_____
/	_____

APPROVED BY	DATE
 J.D. KIM /G.Manager	Nov. 18. 2010
<b>REVIEWED BY</b>  D.H. JANG /S.Manager	Nov. 18. 2010
<b>PREPARED BY</b>  I.S. HWANG /Engineer	Nov. 18. 2010

**Product Engineering Dept.**  
**LG Display Co., Ltd**

**Product Specifications****CONTENTS**

<b>NO.</b>	<b>ITEM</b>	<b>PAGE</b>
0	Record of Revisions	3
1	Summary	4
2	Features	4
3	General Specifications	4
4	Absolute Maximum Ratings	5
5	Electrical Specifications	6
6	Electro-optical Characteristics	22
7	Mechanical Characteristics	25
8	Reliability Test	28
9	International Standards	29
10	Packing	30
11	Precautions	32

## Product Specifications

### RECORD OF REVISIONS

Revision No.	Revision Date	Page	Summary		
0.0	Oct. 1. 2009	-	First Draft (Preliminary)		
1.0	May. 14. 2010	4	Update the Block Diagram to facilitate the understanding.		
		4, 24	Change the LCM Weight Specification - 85g(Typ.) → 85g(Max.)		
		5	Correct the Absolute Maximum Rating Specification. - VGH Maximum Voltage. (40V → 39V)		
		9	Change the Electrical Characteristics Min. & Max. value.		
		10	Update the Driver IC supply current notes 3 & 4. - Add measurement Pattern & Signal condition.		
		11	Change the LED Electrical Characteristics. - Delete Ambient Temp. vs Current graph. - Correct LED Pin map. (THER+/-)		
		12	Change the Interface timing Min. & Max. value.		
		15	Change the Digital RGB timing Min. & Max. value.		
		18	Add the power on sequence.		
		19	Add the power off sequence.		
		20	Change the power supply sequence. - Update Power sequence Graph & Table.		
		26	Change the Rear view drawing. - Add detail dimension about Panel FPC & Backlight FPC.		
		1.1	Nov. 18. 2010	5	Update "4. Absolute Maximum Rating" - Delete temperature Condition row (Ta=25°C).
				8,11,26	Change the LED Symbol. - VLED → Anode, FB→ Cathode.
11	Update "5. LED Electrical characteristics" - Delete temperature Condition (Ta=25°C). - Add LED Voltage per temperature(25°C, -30°C, 85°C).				
12	Add LED Current derating curve.				
27	Change the Rear view drawing. - A shape of LED FPC Tape.				
32	Update "11-2.(2) OPERATING PRECAUTIONS" - Delete the phrase of corresponding to CCFL backlight.				
-	-	Final Specification.			

## Product Specifications

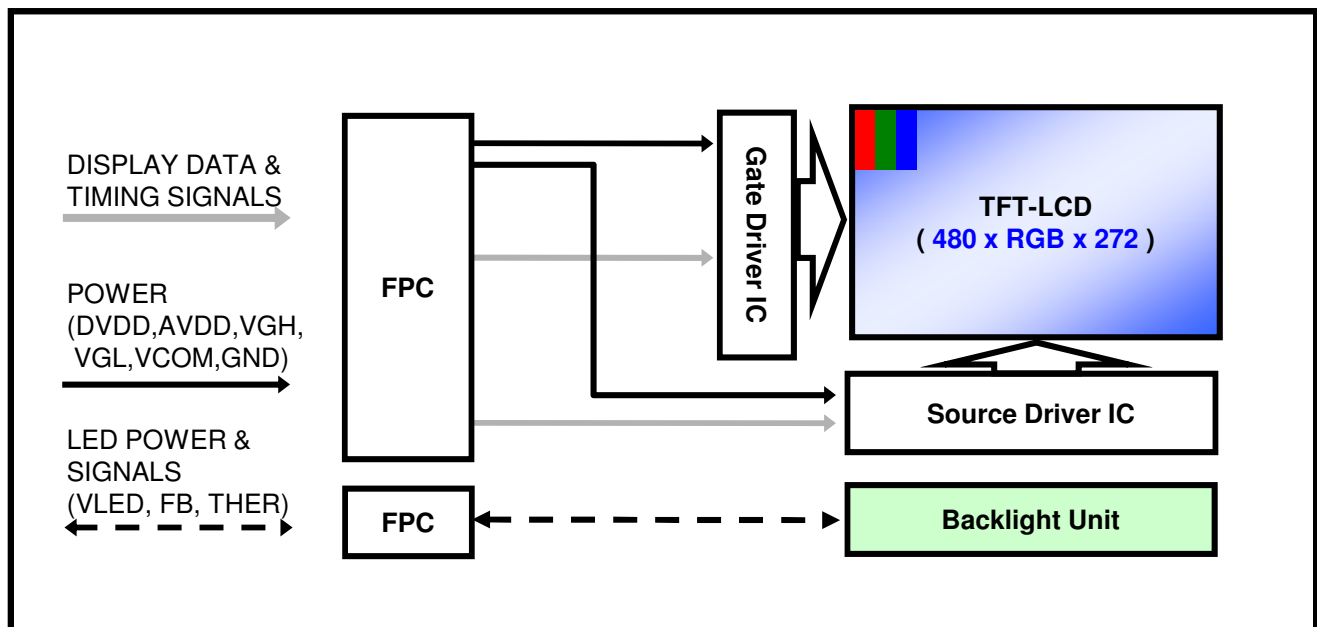
### 1. Summary

This module utilizes amorphous silicon thin film transistors and a aspect ratio of 16:9. The 4.3" active matrix liquid crystal display allows 262,144 colors to be displayed by Digital RGB signal(18bit TTL level) input interface is available.

The applications are display for car audio display and other AV systems for vehicle.

### 2. Features

- Applying a panel with aspect ratio of 16:9, which makes the module suitable for use in wide-screen systems.
- The 4.3" screen produces a high resolution image that is composed of 130,560 RGB pixel elements in a stripe arrangement.
- Technology of wide viewing angle is employed.
- By adopting an active matrix drive, high contrast picture or image is realized.
- By using of COG mounting technology, the module became thin, light and compact.



### 3. General Features

@T<sub>a</sub>=25°C, Aging time: Over 10 minutes

Active Screen Size	4.3 Inches Diagonal
Outline Dimension	105mm (H) X 67mm (V) X 7.4mm (T) (Typ.)
Pixel Pitch	0.198mm × 0.198mm
Pixel Format	480(H) X 3(R,G,B) X 272(V), RGB Vertical Stripes
Color Depth	6-bit, 262,144 Colors
Luminance, White	400 cd/m <sup>2</sup> (Min.)
Weight	85g(Max.)
Display Operating Mode	TN mode, Normally White
Surface Treatment	Anti-Glare

## Product Specifications

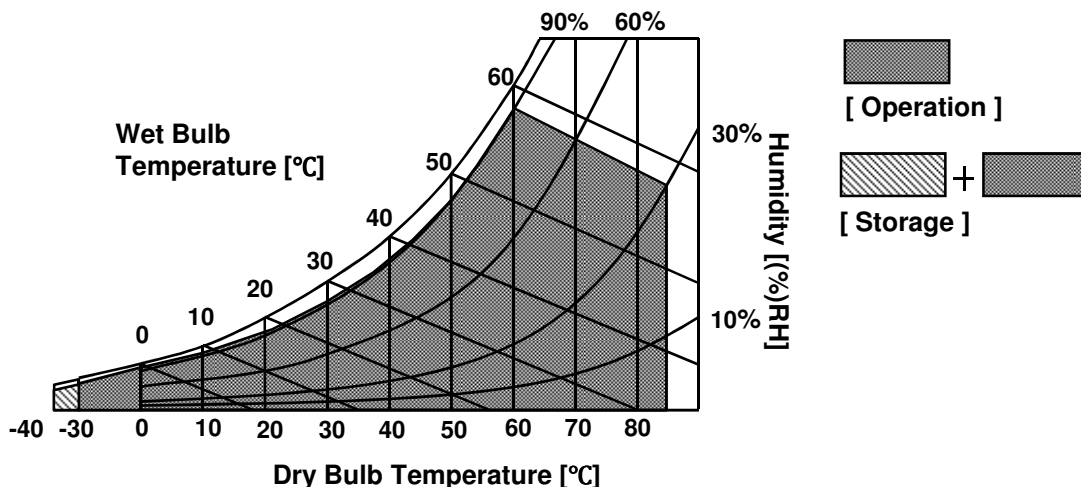
### 4. Absolute Maximum Rating

The followings are maximum values which, if exceeded, may cause malfunction or damage to the Module.

Parameter	Symbol	Min.	Max.	Unit	Notes
Logic Voltage	DVDD	-0.3	3.6	V	
Source Driver Voltage	AVDD	-0.3	13.5	V	
Digital Input Signals	$V_{I1}$	-0.3	DVDD+0.3	V	1
Analog Input Signals	$V_{I2}$	-0.3	AVDD+0.3	V	2
Gate Driver Voltage	VGH	-0.3	39	V	
	VGL	-12	0.3	V	
	VGH-VGL	-0.3	39	V	
Storage Temperature	$T_{ST}$	-40	85	°C	3
Operating Temperature	$T_{OP}$	-30	85	°C	3,4,5

Notes :

- GSPU, GSPD, GSC, GOE, SSPL, SSPR, SSC, SOE, R0-5/G0-5/B0-5, POL, REV
- VCOM, VREF1/2/3/4/5/6/7/8/9/10
- Maximum wet-bulb temperature is 58°C. Condensation of dew must be avoided, because it may cause electrical current leakage, and deterioration of performance and quality.
- The operating temperature means that LCD Module guarantees operation of the circuit.  
All the contents of Electro-optical specifications are guaranteed under the room temperature condition.
- This temperature is ambient temperature with regard to the heat which is generated under operation of circuit and backlight on. (reference value)



## Product Specifications

### 5. Electrical Specifications

#### 5-1. FPC pin assignment

This LCD employs two interface connections, one FPC is used for the module electronics interface and the other FPC is used for the integral backlight system.

##### 5-1-1. Panel FPC Pin Configuration

The matching Connector model name is GF05A-60S-AF manufactured by LS Cable or equivalent.

Pin	Symbol	I/O	Description	Notes
1	VCOM	I	Voltage applied to Color Filter Substrate	
2	VCOM	I	Voltage applied to Color Filter Substrate	
3	GND	I	Ground	
4	VGL	I	Gate Driver Negative Voltage	
5	VGL	I	Gate Driver Negative Voltage	
6	GSPU	I	Gate Scanning Start Signal (Up → Down)	
7	N.C.	-	No Connection	
8	GSC	I	Gate Driver Scanning Clock Signal	
9	GOE	I	Gate Driver Output Enable Signal	
10	GSPD	O	Gate Scanning Start Signal (Down → Up)	No Connection
11	GND	I	Ground	
12	GND	I	Ground	
13	VGH	I	Gate Driver Positive Voltage	
14	GND	I	Ground	
15	SSPR	O	Source Scanning Start Signal (Right → Left)	No Connection
16	DVDD	I	Power Supply for Drivers Logic	
17	DVDD	I	Power Supply for Drivers Logic	
18	DVDD	I	Power Supply for Drivers Logic	
19	GND	I	Ground	
20	SSC	I	Source Driver Clock Signal	
21	GND	I	Ground	
22	GND	I	Ground	
23	GND	I	Ground	
24	AVDD	I	Power Supply for Source Driver	
25	AVDD	I	Power Supply for Source Driver	
26	POL	I	Polarity Control Signal	
27	SOE	I	Source Driver Output Enable Signal	
28	N.C.	-	No Connection	
29	REV	I	Pixel Data Inversion Signal	1
30	R5	I	Red Data 5 [MSB]	

**Product Specifications**

Pin	Symbol	I/O	Description	Notes
31	R4	I	Red Data 4	
32	R3	I	Red Data 3	
33	R2	I	Red Data 2	
34	R1	I	Red Data 1	
35	R0	I	Red Data 0 [LSB]	
36	G5	I	Green Data 5 [MSB]	
37	G4	I	Green Data 4	
38	G3	I	Green Data 3	
39	G2	I	Green Data 2	
40	G1	I	Green Data 1	
41	G0	I	Green Data 0 [LSB]	
42	B5	I	Blue Data 5 [MSB]	
43	B4	I	Blue Data 4	
44	B3	I	Blue Data 3	
45	B2	I	Blue Data 2	
46	B1	I	Blue Data 1	
47	B0	I	Blue Data 0 [LSB]	
48	VREF10	I	Gamma Correction Voltage10	
49	VREF9	I	Gamma Correction Voltage9	
50	VREF8	I	Gamma Correction Voltage8	
51	VREF7	I	Gamma Correction Voltage7	
52	VREF6	I	Gamma Correction Voltage6	
53	VREF5	I	Gamma Correction Voltage5	
54	VREF4	I	Gamma Correction Voltage4	
55	VREF3	I	Gamma Correction Voltage3	
56	VREF2	I	Gamma Correction Voltage2	
57	VREF1	I	Gamma Correction Voltage1	
58	GND	I	Ground	
59	SSPL	I	Source Scanning Start Signal (Left → Right)	
60	GND	I	Ground	

1. REV is a option pin for EMI noise reduction.

If Timing Controller IC is not supported REV function, REV input pin should be connected to GND.

**Product Specifications****5-1-2. Backlight FPC Pin Configuration**

The matching Connector model name is TF12-9S-0.5SH manufactured by HIROSE or equivalent.

<b>Pin</b>	<b>Symbol</b>	<b>Description</b>	<b>Notes</b>
1	N.C.	No Connection	
2	Anode	Power Supply for Backlight	
3	N.C.	No Connection	
4	Cathode1	Feedback current of channel1	
5	Cathode2	Feedback current of channel2	
6	N.C.	No Connection	
7	THER+	Thermal sensor output(+)	
8	THER-	Thermal sensor output(-)	
9	N.C.	No Connection	

**Product Specifications**
**5-2. Electrical Characteristics**

 @T<sub>a</sub>=25°C, Aging time: Over 10 minutes

Parameter		Symbol	Min.	Typ.	Max.	Unit	Notes	
Source Driver	Logic Supply Voltage	DVDD	3.0	3.3	3.6	V		
	Analog Supply Voltage	AVDD	8.0	10.0	12.0	V		
	Gamma Correction Voltage	VREF	GND+0.5	-	AVDD-0.5	V	2	
	Logic High Level	V <sub>IH</sub>	2.7	-	DVDD	V		
	Logic Low Level	V <sub>IL</sub>	0	-	0.3	V		
Gate Driver	TFT	High	VGH	15	18.5	22	V	
		Low	VGL	-8.0	-6.8	-5.0	V	
		Voltage Difference	VGH-VGL	20.0	-	30.0	V	
	Logic Supply Voltage	DVDD	3.0	3.3	3.6	V		
	Logic High Level	V <sub>IH</sub>	2.7	-	DVDD	V		
	Logic Low Level	V <sub>IL</sub>	0	-	0.3	V		
Color Filter Substrate Voltage		VCOM	3.0	3.9	5.0	V		
		I <sub>VCOM</sub>	-	-	5	mA		
Source Driver	Analog Voltage Supply Current	I <sub>AVDD</sub>	-	-	35	mA	3	
	Logic Voltage Supply Current	I <sub>DVDD</sub>	-	-	10	mA	3	
Gate Driver	High Voltage Supply Current	I <sub>VGH</sub>	-	-	1	mA	4	
	Low Voltage Supply Current	I <sub>VGL</sub>	-	-	1	mA	4	
	Logic Voltage Supply Current	I <sub>DVDD</sub>	-	-	3	mA	4	

**Notes :**

- The recommended operating conditions show the ranges in which the device can operate normally. Operation beyond the limit of the recommended operation conditions is not assured, even though operating conditions are within the limit of the maximum ratings.

**Product Specifications**

2. Recommended Gamma Correction Voltage [VREF1 to VREF10]  
 Recommended Gamma Correction Voltage is adapted to Gamma 2.2 curve.

Symbol	Typ.	Unit	Notes
VREF1	9.20	V	5
VREF2	8.70	V	
VREF3	7.18	V	
VREF4	6.23	V	
VREF5	5.94	V	
VREF6	4.43	V	6
VREF7	4.04	V	
VREF8	3.01	V	
VREF9	1.14	V	
VREF10	0.57	V	

3.  $V_{IH} = DVDD$ ,  $V_{IL} = GND$ , SOE Pulse Width = 2.32us, fssc = 10.16MHz, AVDD = 10V,  
 Recommended Gamma Correction Voltage, Black pattern.
4.  $V_{IH} = DVDD$ ,  $V_{IL} = GND$ , GOE Pulse Width = 2.68us, fGSC = 17.16kHz, fGSP = 60Hz,  
 Black pattern.
5. VREF1 to VREF5 relationships of  
 $AVDD - 0.5V > VREF1 > VREF2 > VREF3 > VREF4 > VREF5 > 0.45 \cdot AVDD$
6. VREF6 to VREF10 relationships of  
 $0.55 \cdot AVDD > VREF6 > VREF7 > VREF8 > VREF9 > VREF10 > GND + 0.5V$

**Product Specifications**

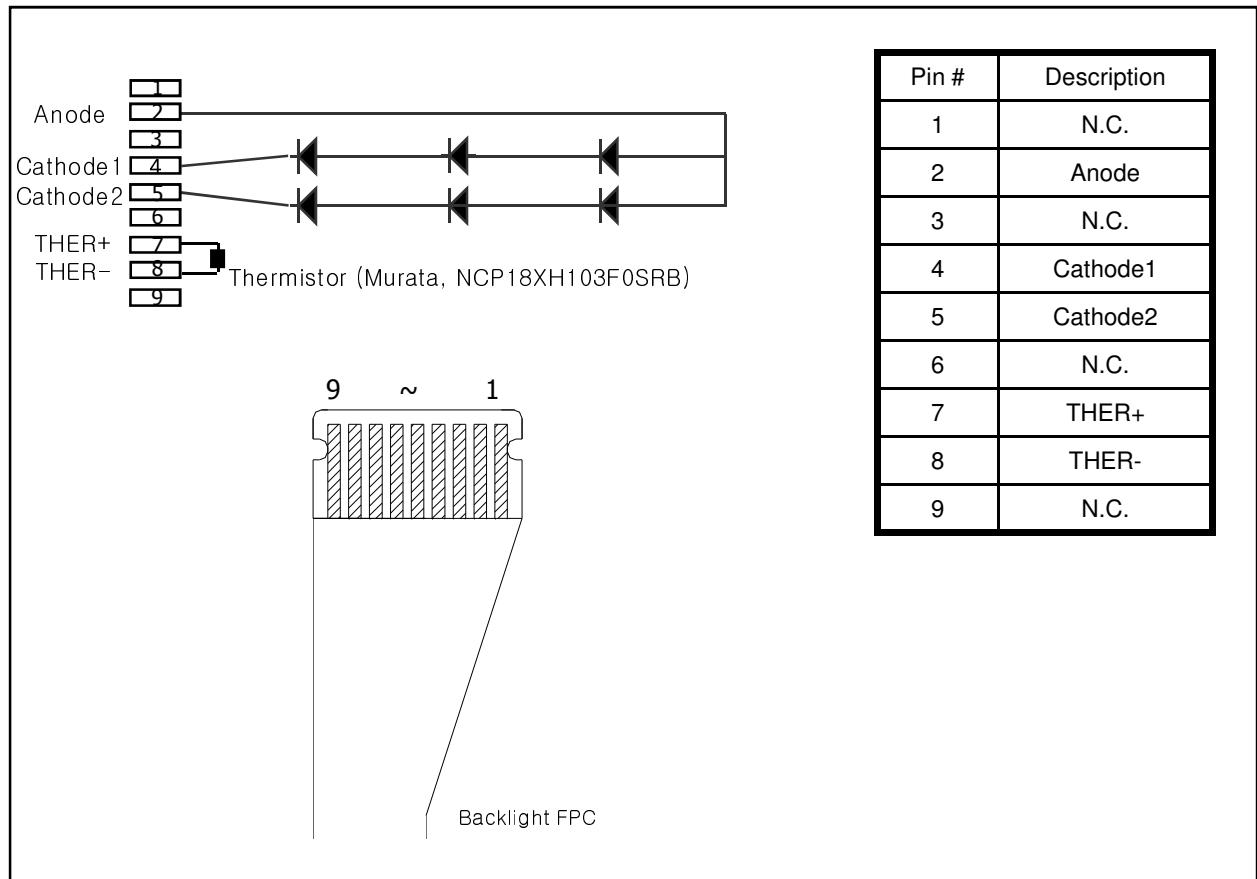
**5-3. LED Electrical Characteristics**

@ Aging time: Over 10 minutes

Parameter	Symbol	Values			Unit	Notes
		Min	Typ	Max		
LED current per chain	$I_{LED}$	-	75	80	mA	1,3
LED voltage	VLED		8.7	9.9	V	25°C
			9.6	10.8		-30°C
		-	8.2	9.36	V	85°C
LED power	PLED	-	1.3	1.92	W	
LED chain	-	-	2	-	-	2

Notes 1. The permissible forward current of LED vary with environmental temperature.

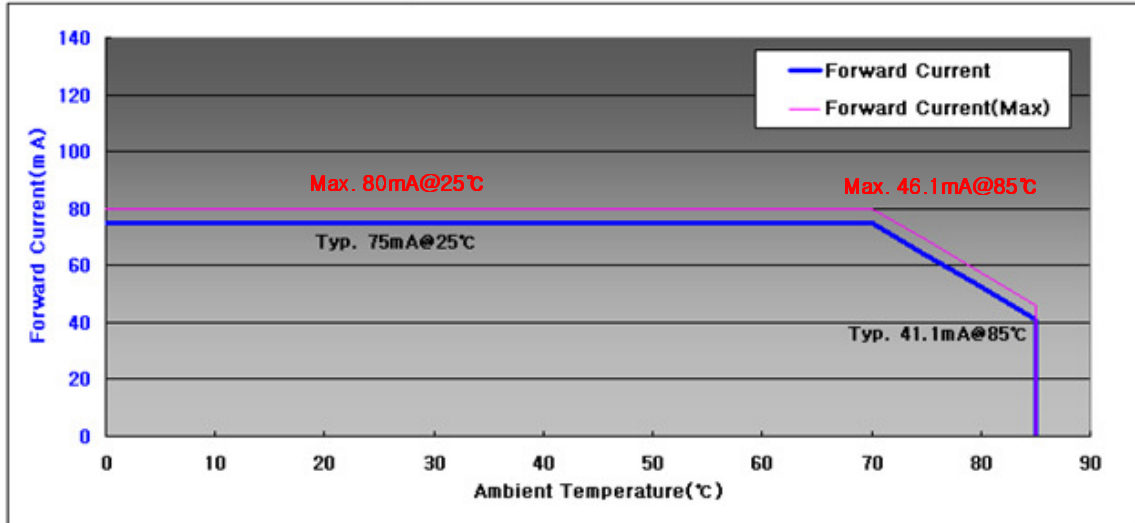
Notes 2. LED chain diagram.



**Product Specifications**

Notes 3. LED Current derating curve.

Ambient Temperature vs. Allowable Forward Current



## Product Specifications

### 5-4. Interface Timing Specification

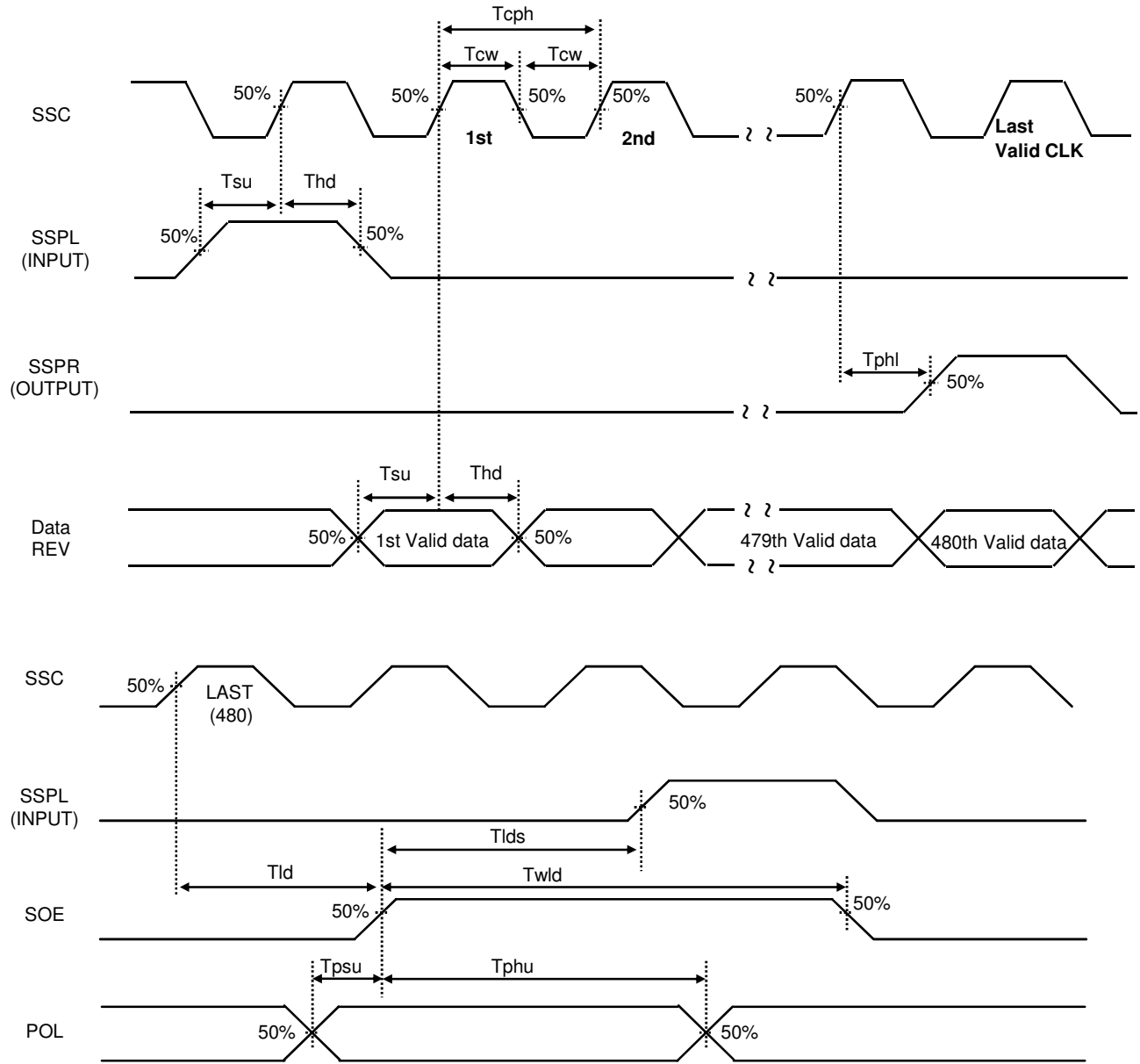
#### 5-4-1. Timing Characteristics of Driver IC input signals

	Parameter	Symbol	Min.	Typ.	Max.	Unit	Notes
<b>S O U R C E</b>	SSC Frequency	Fclk	8.5	10.16	11.57	MHz	Fig. 1
	SSC Pulse Width	Tcw	8	-	-	ns	
	DATA/REV/SSPL Setup Time	Tsu	4	-	-	ns	
	DATA/REV/SSPL Hold Time	Thd	2	-	-	ns	
	SSPR Delay Time	Tphl	-	-	18	ns	
	Time that the last data to SOE	Tld	1			Tcph	
	SOE Pulse Width	Twld	2	-	-	Tcph	
	Time that SOE to SSPL	Tlds	5	-	-	Tcph	
	POL Set up Time	Tpsu	6	-	-	ns	
	POL Hold Time	Tphd	6	-	-	ns	
<b>G A T E</b>	GSC Clock Frequency	fGSC	16.86	17.16	17.64	KHz	Fig. 2
	GSC Clock Pulse Width	tCWH	2	-	-	us	
		tCWL	2	-	-	us	
	Input Signal Rising Time (GSC/GSP/GOE)	tr	-	-	100	ns	
	Input Signal Falling Time (GSC/GSP/GOE)	tf	-	-	100	ns	
	GOE Enable Time	tWGOE	1	-	-	us	
	GSP Setup Time	tsu	500	-	-	ns	
	GSP Hold Time	thd	500	-	-	ns	
	Driver Output Delay Time	tpd1	-	500	1000	ns	
	GOE to Output Delay Time	tpd2	-	500	1000	ns	
GSP Delay Time	tpd3	-	500	1000	ns		

**Product Specifications**

**5-4-2. Timing Diagram**

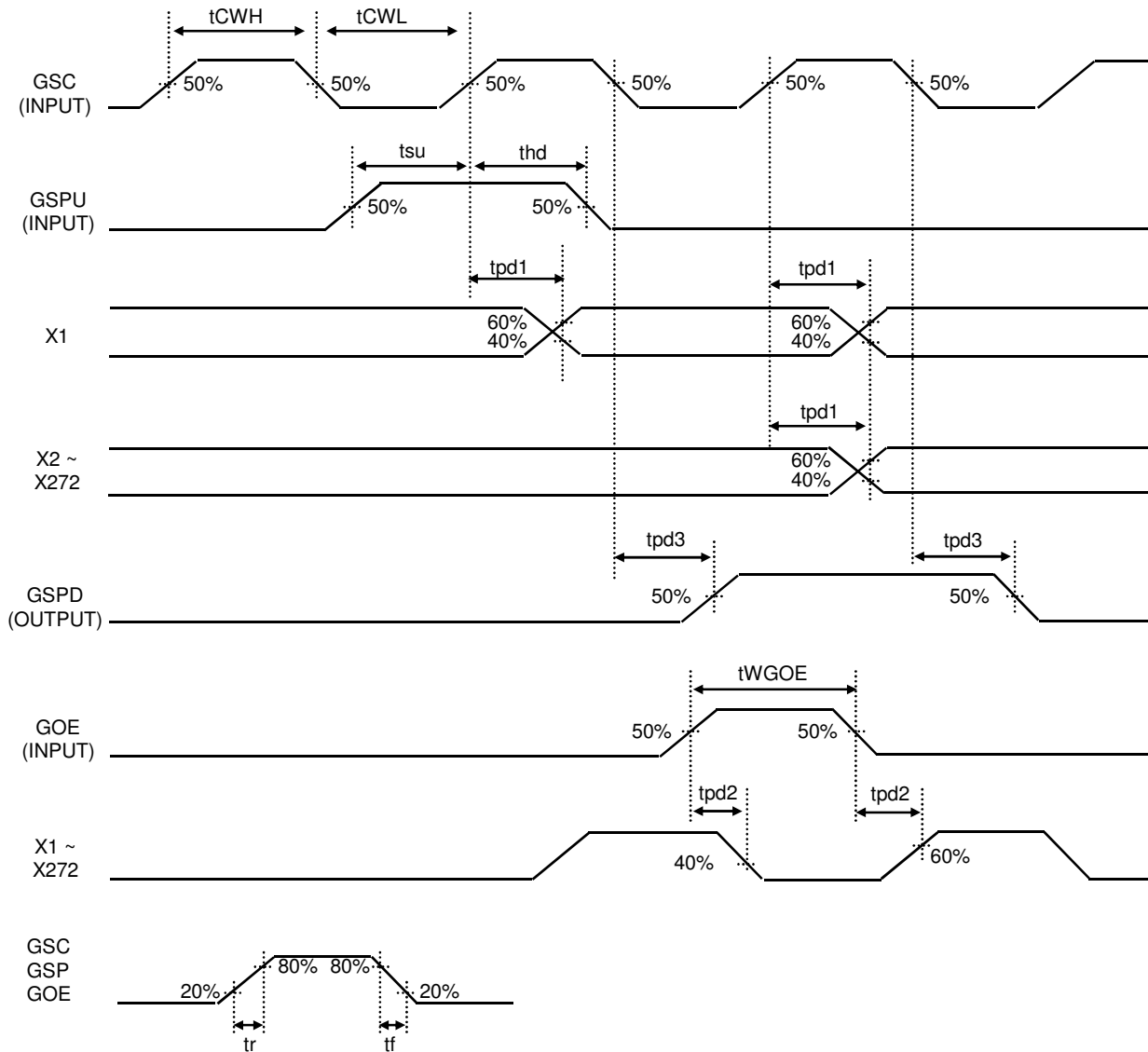
① Source D-IC Timing Diagram



[Fig. 1]

**Product Specifications**

② Gate D-IC Timing Diagram



[Fig. 2]

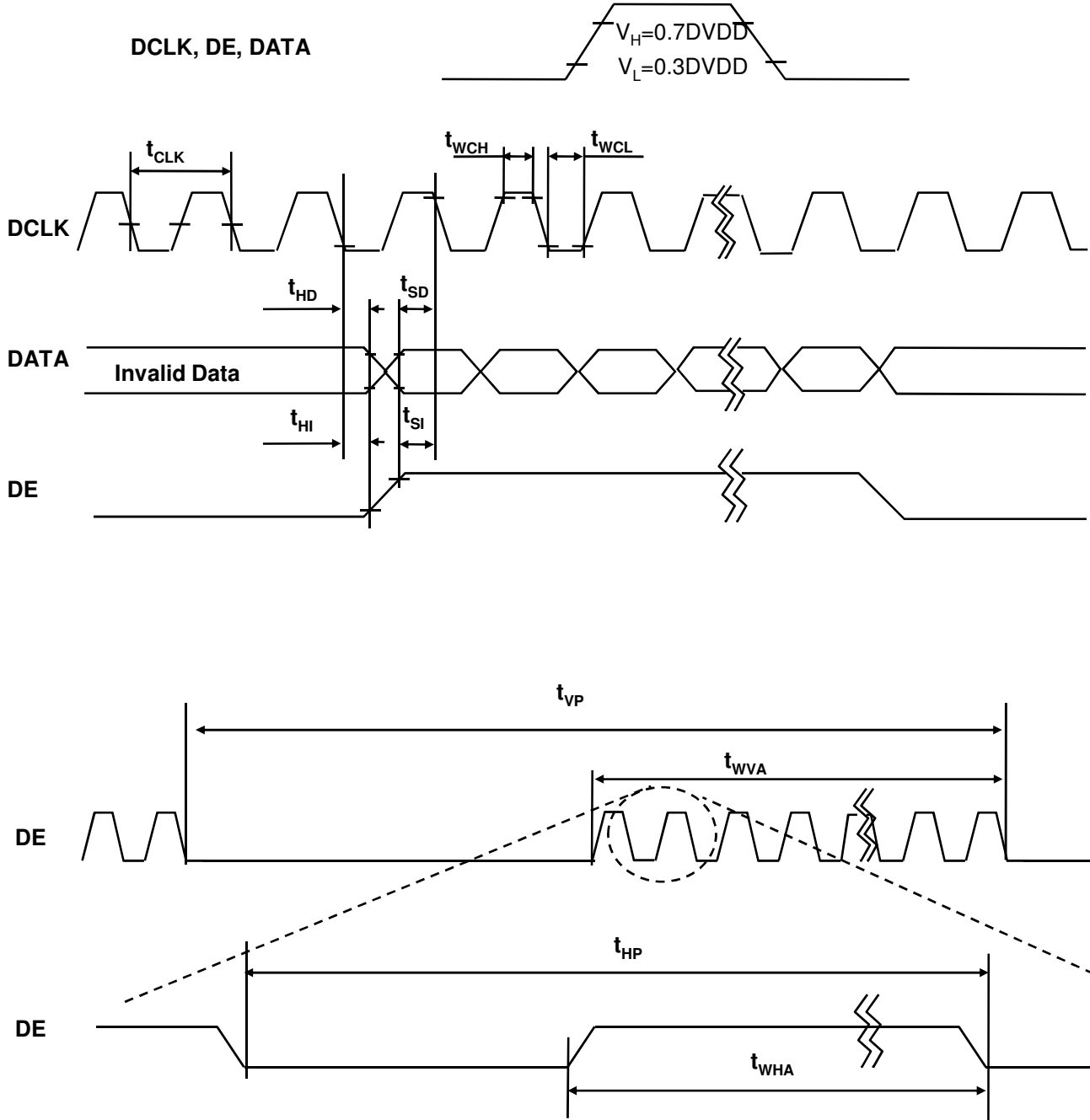
**Product Specifications**
**5-4-3. Digital RGB Timing Table**

ITEM		Symbol	MIN.	TYP.	MAX.	UNIT	NOTE
DCLK	Frequency	$f_{CLK}$	8.5	10.16	11.57	MHz	
	Width_Low	$t_{WCL}$	8	-	-	ns	
	Width_High	$t_{WCH}$	5	-	-		
Vertical	Frequency	$f_{VP}$	60	60	60	Hz	$f_{CLK} / (t_{HP} * t_{VP})$
DE	Setup Time	$t_{SI}$	6	-	-	ns	
	Hold Time	$t_{HI}$	6	-	-		
	Horizontal Valid	$t_{WHA}$	480	480	480	$t_{CLK}$	
	Horizontal Period	$t_{HP}$	504	592	656		
	Vertical Valid	$t_{WVA}$	272	272	272	$t_{Hp}$	
	Vertical Period	$t_{VP}$	281	286	294		
DATA	Setup Time	$t_{SD}$	6	-	-	ns	
	Hold Time	$t_{HD}$	6	-	-		

Note: All of the interface signal timing should be satisfied with the above specifications for its proper operation.

**Product Specifications**

**5-4-4. Digital RGB Timing Diagram**



## Product Specifications

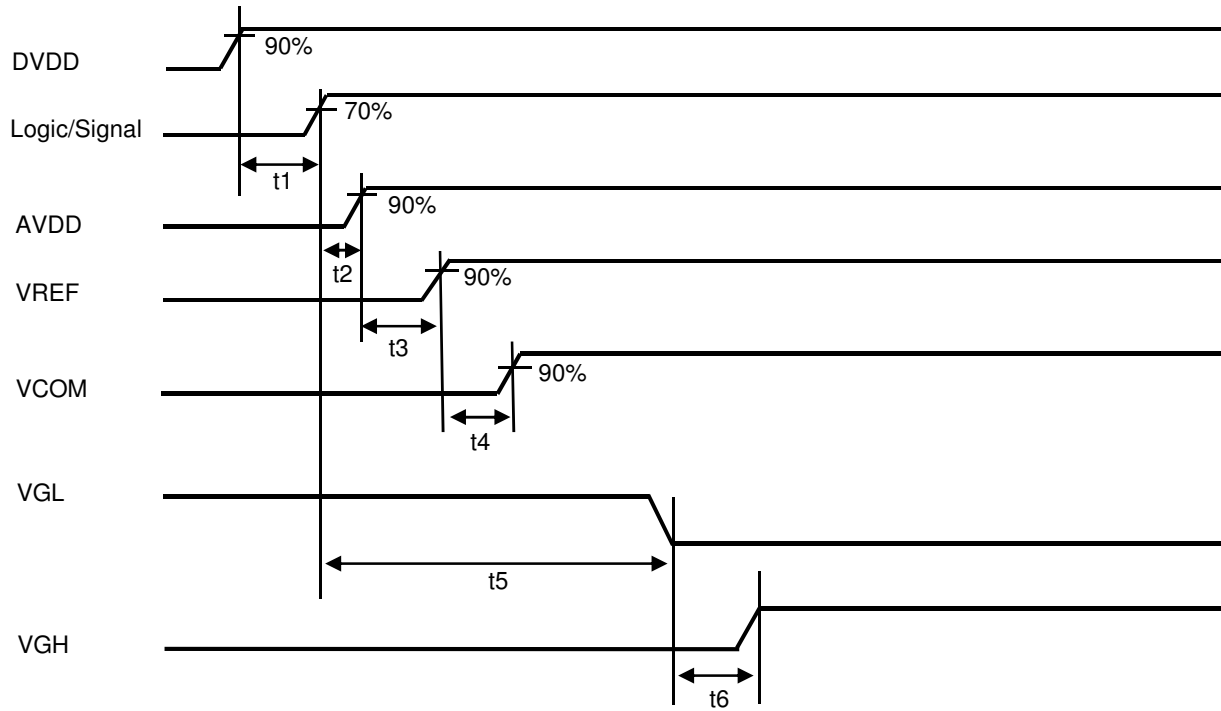
### 5-4-5. Color Input Data Reference(Digital RGB)

The brightness of each primary color(red,green and blue) is based on the 6-bit gray scale data input for the color ; the higher the binary input, the brighter the color.

The following table provides a reference for color versus data input.

#### COLOR DATA REFERENCE

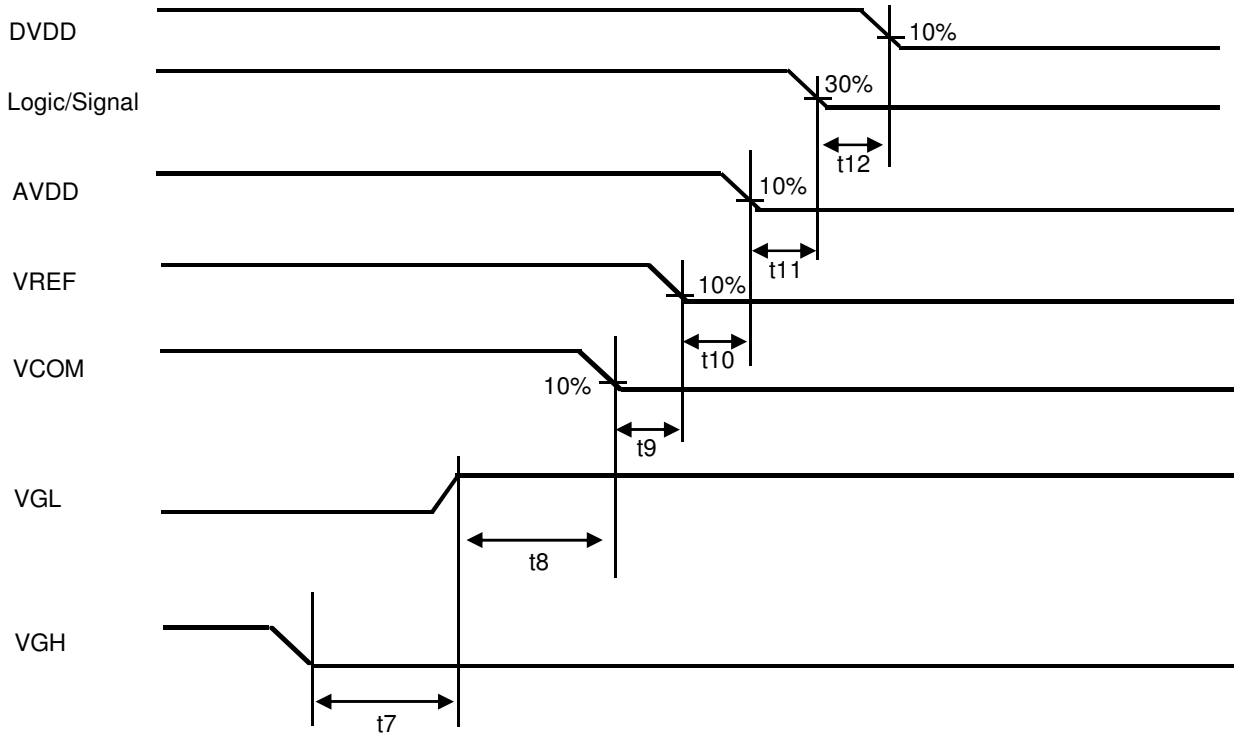
Color		Input Color Data																			
		Red						Green						Blue							
		MSB		Red				LSB		MSB		Green				LSB		MSB		Blue	
R5	R4	R3	R2	R1	R0	G5	G4	G3	G2	G1	G0	B5	B4	B3	B2	B1	B0				
Basic Colors	Black	0	0	0	0	0	0	0	0	0	0	0	0	0	0	0	0	0			
	Red(63)	1	1	1	1	1	1	0	0	0	0	0	0	0	0	0	0	0			
	Green(63)	0	0	0	0	0	0	1	1	1	1	1	1	0	0	0	0	0			
	Blue(63)	0	0	0	0	0	0	0	0	0	0	0	0	1	1	1	1	1			
	Cyan	0	0	0	0	0	0	1	1	1	1	1	1	1	1	1	1	1			
	Magenta	1	1	1	1	1	1	0	0	0	0	0	0	1	1	1	1	1			
	Yellow	1	1	1	1	1	1	1	1	1	1	1	1	0	0	0	0	0			
	White	1	1	1	1	1	1	1	1	1	1	1	1	1	1	1	1	1			
Red	Red(00) Dark	0	0	0	0	0	0	0	0	0	0	0	0	0	0	0	0	0			
	Red(01)	0	0	0	0	0	1	0	0	0	0	0	0	0	0	0	0	0			
	Red(02)	0	0	0	0	1	0	0	0	0	0	0	0	0	0	0	0	0			
	:	:	:	:	:	:	:	:	:	:	:	:	:	:	:	:	:	:			
	Red(61)	1	1	1	1	0	1	0	0	0	0	0	0	0	0	0	0	0			
	Red(62)	1	1	1	1	1	0	0	0	0	0	0	0	0	0	0	0	0			
	Red(63) Bright	1	1	1	1	1	1	0	0	0	0	0	0	0	0	0	0	0			
Green	Green(00)Dark	0	0	0	0	0	0	0	0	0	0	0	0	0	0	0	0	0			
	Green(01)	0	0	0	0	0	0	0	0	0	0	1	0	0	0	0	0	0			
	Green(02)	0	0	0	0	0	0	0	0	0	1	0	0	0	0	0	0	0			
	:	:	:	:	:	:	:	:	:	:	:	:	:	:	:	:	:	:			
	Green(61)	0	0	0	0	0	0	1	1	1	1	0	1	0	0	0	0	0			
	Green(62)	0	0	0	0	0	0	1	1	1	1	1	0	0	0	0	0	0			
	Green(63)Bright	0	0	0	0	0	0	1	1	1	1	1	1	0	0	0	0	0			
Blue	Blue(00) Dark	0	0	0	0	0	0	0	0	0	0	0	0	0	0	0	0	0			
	Blue(01)	0	0	0	0	0	0	0	0	0	0	0	0	0	0	0	0	1			
	Blue(02)	0	0	0	0	0	0	0	0	0	0	0	0	0	0	0	1	0			
	:	:	:	:	:	:	:	:	:	:	:	:	:	:	:	:	:	:			
	Blue(61)	0	0	0	0	0	0	0	0	0	0	0	1	1	1	1	0	1			
	Blue(62)	0	0	0	0	0	0	0	0	0	0	0	1	1	1	1	1	0			
	Blue(63) Bright	0	0	0	0	0	0	0	0	0	0	0	1	1	1	1	1	1			

**Product Specifications**
**5-4-6. Power on sequence**


Parameter		Timing			Unit	Notes
		Min.	Typ.	Max.		
Power On	t1	100u	10m	-	Sec	
	t2	0m	-	-		
	t3	0m	-	-		
	t4	0m	-	-		
	t5	20m	-	-		
	t6	10m	-	-		

Notes :

1. If it is difficult to perform as our recommendation, customer should ask to LG Display.

**Product Specifications**
**5-4-7. Power off sequence**


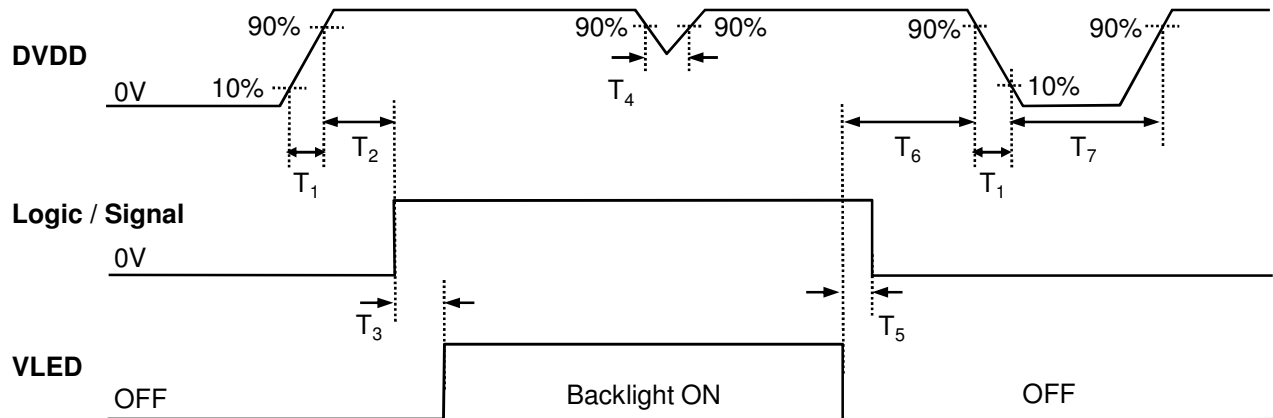
Parameter		Timing				Notes
		Min.	Typ.	Max.	Unit	
Power On	t7	0m	-	-	Sec	
	t8	0m	-	-		
	t9	0m	-	-		
	t10	0m	-	-		
	t11	0m	-	-		
	t12	0m	-	-		

Notes :

1. Power on sequence must be observed to restart LCM after Power off.
2. If it is difficult to perform as our recommendation, customer should ask to LG Display.

**Product Specifications**
**5-5. Power Supply Sequence**

For LCD's normal operation, it is recommended to keep below power supply sequence.



Parameter	Value			Units	Note
	Min.	Typ.	Max.		
T <sub>1</sub>	0	-	10	(ms)	
T <sub>2</sub>	100	-	-	(us)	
T <sub>3</sub>	600	-	-	(ms)	
T <sub>4</sub>	-	-	100	(us)	1
T <sub>5</sub>	0	-	-	(ms)	
T <sub>6</sub>	0	-	T <sub>7</sub>	(ms)	
T <sub>7</sub>	1500	-	-	(ms)	

Notes :

1. Power deep time. If it is longer than the T<sub>4</sub> maximum value, LCD would be abnormal state. In this case, you must re-initialize the LCD in accordance with "Power Supply Sequence".
2. If it is difficult to perform as our recommendation, customer should ask to LG Display.

## Product Specifications

### 6. Electro-optical Characteristics

@T<sub>a</sub>=25°C, Aging time: Over 10 minutes

Parameter		Symbol	Values			Units	Notes
			Min	Typ	Max		
Contrast Ratio		CR	350	500	-	-	1
Surface Luminance, white		L <sub>WH</sub>	400	-	-	cd/m <sup>2</sup>	2
Luminance Variation		δ <sub>WHITE</sub>	80	85	-	%	3
Response Time	Rise Time	Tr <sub>R</sub>	-	7	15	ms	4
	Decay Time	Tr <sub>D</sub>	-	18	30	ms	
Color Coordinates	Red	R <sub>X</sub>	0.579	0.629	0.679	-	2 (Reference Value)
		R <sub>Y</sub>	0.297	0.347	0.397		
	Green	G <sub>X</sub>	0.289	0.339	0.389		
		G <sub>Y</sub>	0.554	0.604	0.654		
	Blue	B <sub>X</sub>	0.098	0.148	0.198		
		B <sub>Y</sub>	0.047	0.097	0.147		
	White	W <sub>X</sub>	0.258	0.308	0.358		
W <sub>Y</sub>		0.276	0.326	0.376			
Viewing Angle	x axis, right (φ =0°)	Θ <sub>r</sub>	65	70	-	degree	5
	x axis, left (φ =180°)	Θ <sub>l</sub>	65	70	-		
	y axis, up (φ =90°)	Θ <sub>u</sub>	55	60	-		
	y axis, down (φ =270°)	Θ <sub>d</sub>	45	50	-		
Life Time		-	10,000	-	-	Hours	6

Notes :

1. Contrast Ratio (CR) is defined mathematically as

$$\text{Contrast Ratio} = \frac{\text{Surface Luminance with all white pixels}}{\text{Surface Luminance with all black pixels}}$$

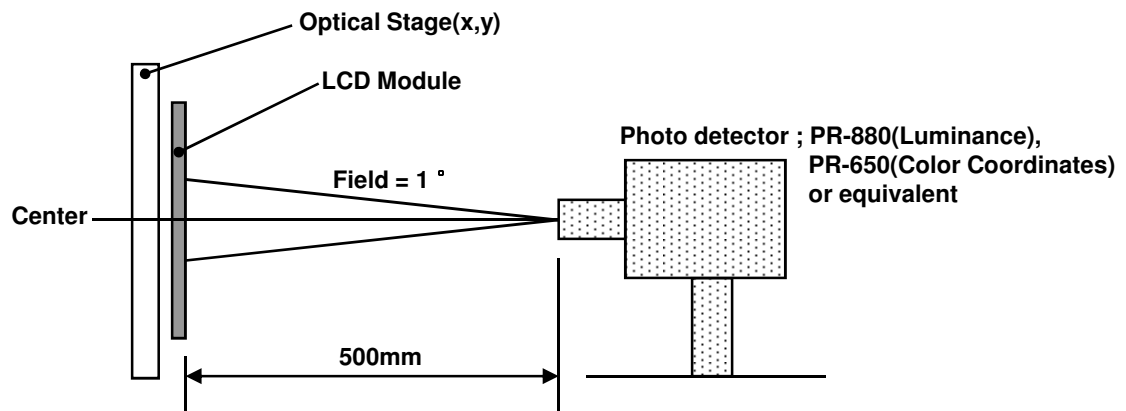
2. Surface luminance is measured at the center point(L1) of the LCD with all pixels displaying white at the distance of 50cm by PR-880. Color Coordinates are measured at the center point(L1) of the LCD with all pixels displaying red, green, blue and white at the distance of 50cm by PR-650. For more information, refer to the Fig. 3 and Fig. 4.
3. The variation in surface luminance. The panel total variation (δ<sub>WHITE</sub>) is determined by measuring LN at each test position 1 through 5, and then dividing the maximum LN of 5 points luminance by minimum LN of 5 points luminance. For more information see Fig. 4.

$$\delta_{\text{WHITE}} = \text{Minimum}(L1, L2, \dots L5) / \text{Maximum}(L1, L2, \dots L5) \times 100$$

## Product Specifications

**Notes :**

4. Response time is the time required for the display to transition from white to black (Rise Time,  $Tr_R$ ) and from black to white (Decay Time,  $Tr_D$ ). For additional information see Fig. 5.
5. Viewing angle is the angle at which the contrast ratio is greater than 10. The angles are determined for the horizontal or x axis and the vertical or y axis with respect to the z axis which is normal to the LCD surface. For more information see Fig. 6.
6. "Life Time" is defined as the time the brightness decreases to 50% from initial brightness which is stabilized under continuous lighting condition, at ambient temperature 25°C.

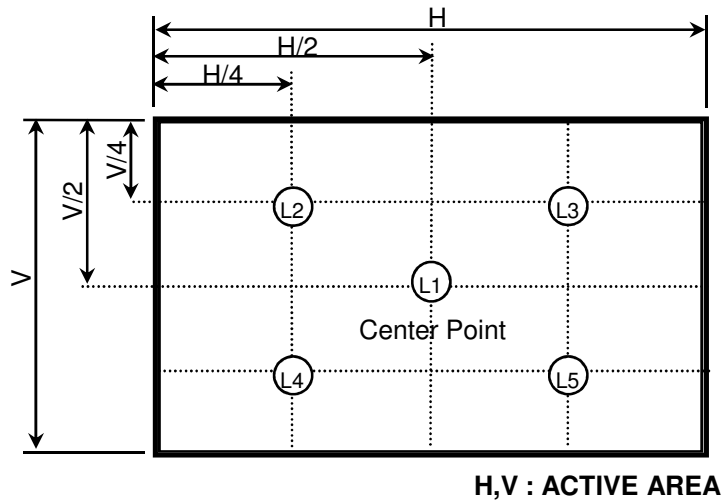
**Fig. 3 Optical Characteristic Measurement Equipment and Method**

**Measuring Conditions ;**

- Surroundings : Dark Room
- Temperature :  $T_a=25^\circ\text{C}$
- Input Video Signal: Digital RGB (18bits)
- Electrical parameters set typical values.
- Measured value at the center point of LCD panel after more than 10 minutes while backlight turning on.

**Product Specifications**

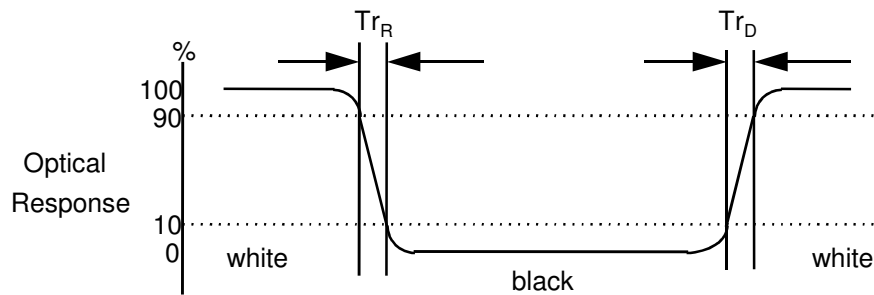
**Fig. 4 Luminance**

<measuring point for surface luminance & measuring point for luminance variation >

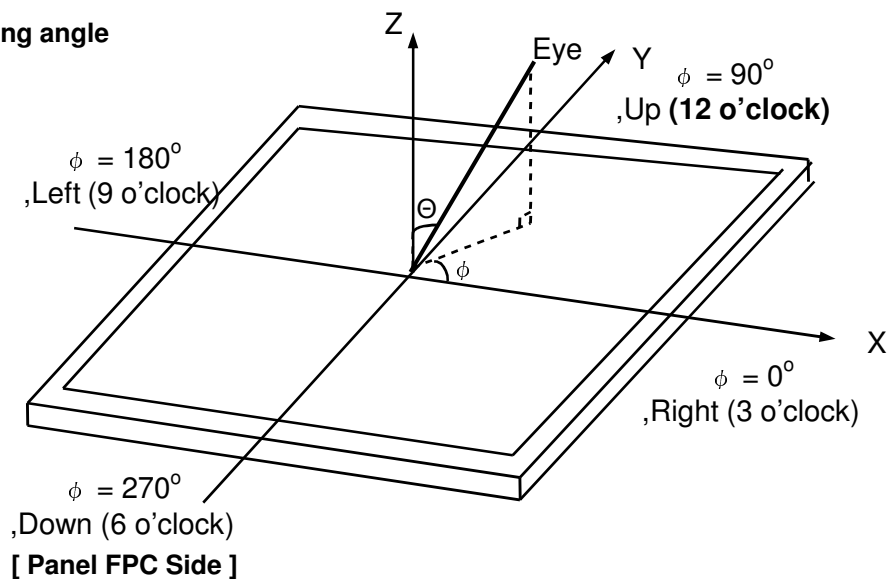


**Fig. 5 Response Time**

The response time is defined as the following figure and shall be measured by switching the input signal for "black" and "white".



**Fig. 6 Viewing angle**



**Product Specifications**
**7. Mechanical Characteristics**

The contents provide general mechanical characteristics for this module.  
 In addition the figures in the next page are detailed mechanical drawing of the LCD.

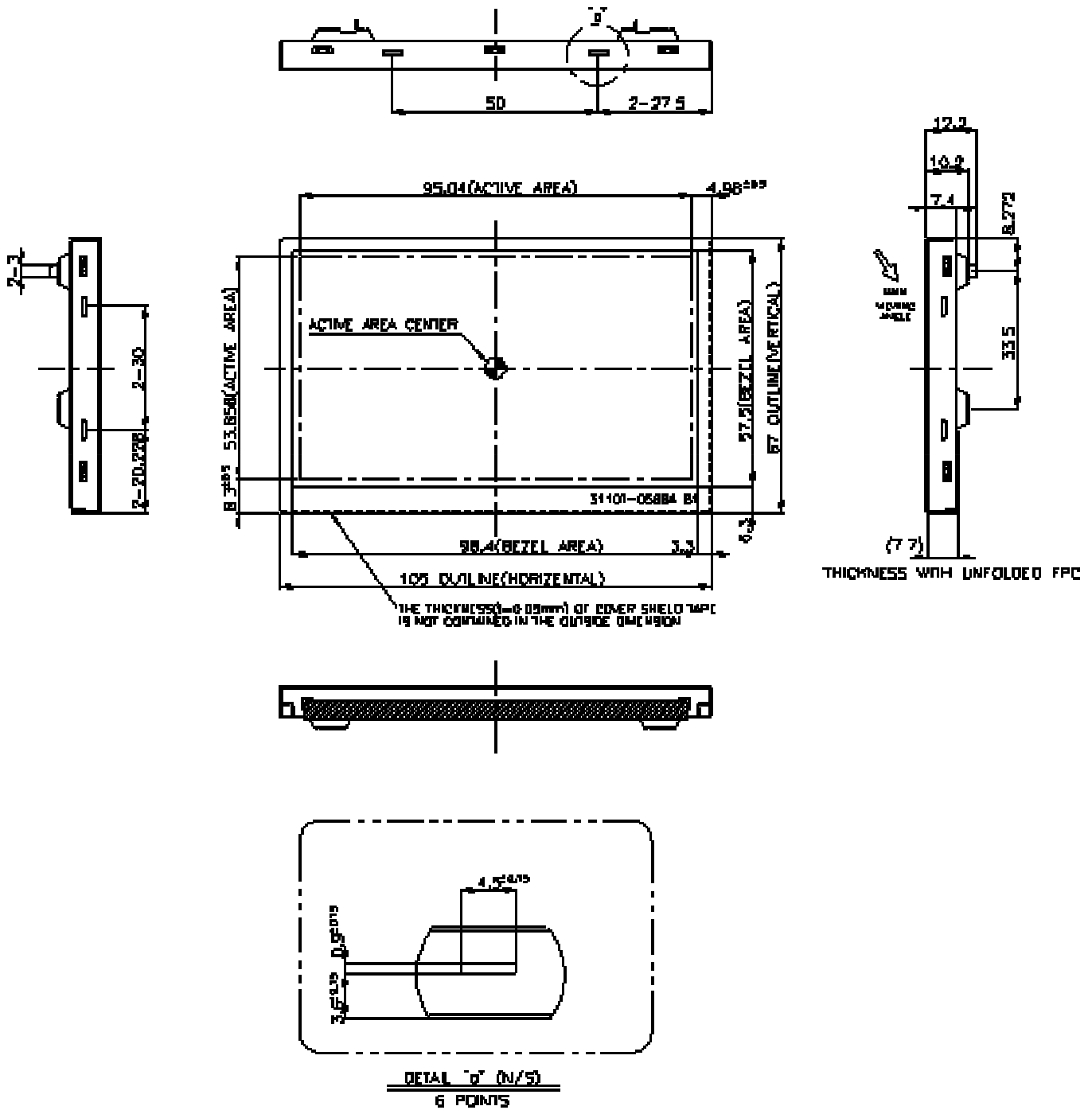
Outline Dimension	Horizontal	105.0(± 0.3)mm
	Vertical	67.0(± 0.3)mm
	Thickness	7.4(± 0.3)mm
Bezel Area	Horizontal	98.4(± 0.3)mm
	Vertical	57.5(± 0.3)mm
Active Display Area	Horizontal	95.04 mm
	Vertical	53.856 mm
Weight	85g (Max.)	

**Product Specifications**

<FRONT VIEW>

Note) Unit:[mm], General tolerance: ± 0.3mm

(12 o'clock direction)

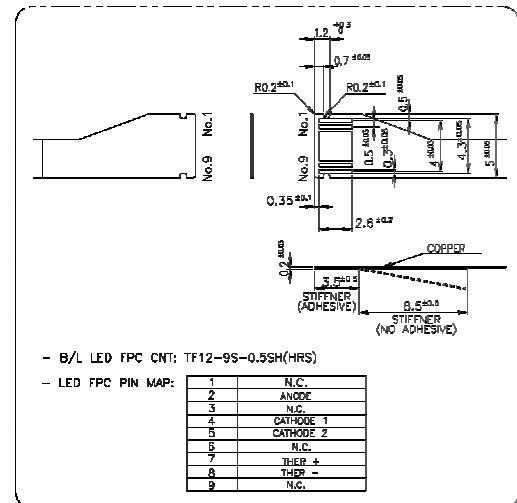
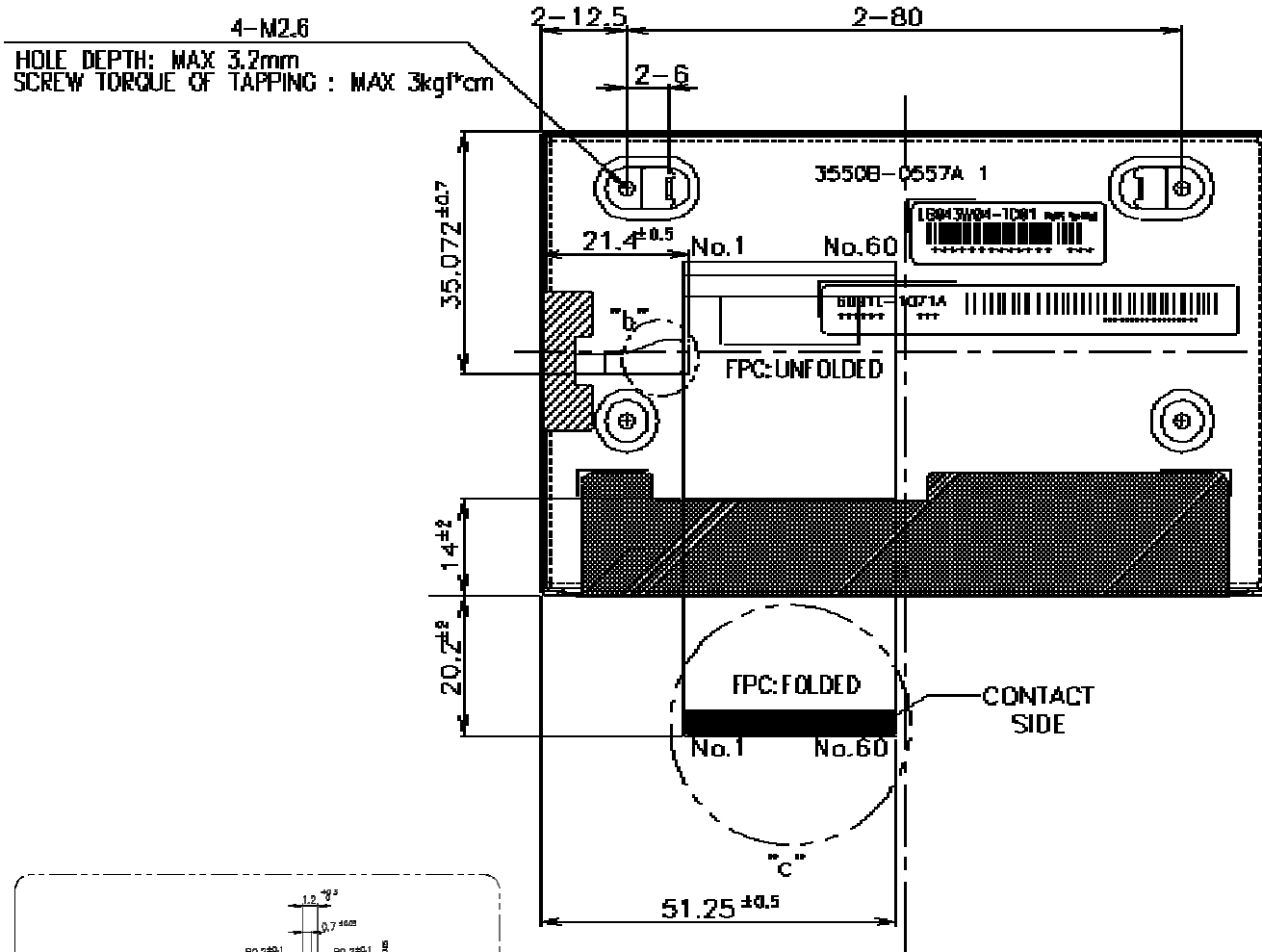


**Product Specifications**

<REAR VIEW>

Note) Unit:[mm], General tolerance: ± 0.3mm

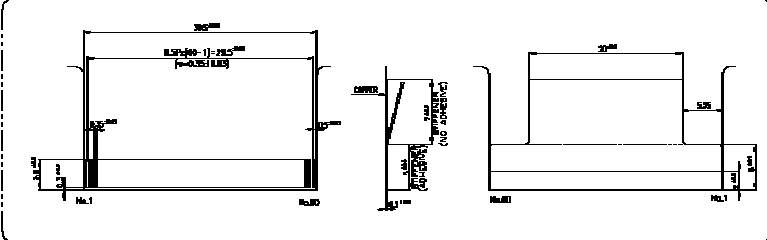
(12 o'clock direction)



- B/L LED FPC CNT: TF12-9S-0.5SH(HRS)

- LED FPC PIN MAP:

1	N.C.
2	ANODE
3	N.C.
4	CATHODE 1
5	CATHODE 2
6	N.C.
7	THSR +
8	THSR -
9	N.C.



DETAIL "b" (N/S)

DETAIL "c" (SIDE VIEW)

## Product Specifications

### 8. Reliability Test

No.	Test Items	Test Condition	Notes
1	High Temperature Storage Test	Ta=85°C 240h	
2	Low Temperature Storage Test	Ta=-40°C 240h	
3	High Temperature Operation Test	Ta=85°C 240h	
4	Low Temperature Operation Test	Ta=-30°C 240h	
5	High Humidity Operation Test	Ta=65°C/90%RH 240h	
6	Humid Heat Cyclic Test	Ta=-10°C~65°C/80~96%RH 240h	
7	Thermal Shock Test	- 1cycle : Ta=-40°C(0.5h) ~ 85°C(0.5h) - 240Cycles	
8	Electro Static Discharge Test	- Panel Surface : ±15kV, Air, Power On - Case Top, Cover Bottom : ±10kV, Direct, Power Off (Air : 330pF, 2kΩ / Direct : 150pF, 2kΩ / 10 times)	
9	Shock Test (non-operating)	Half sine wave, 50G, 11ms, three times One in each opposite direction of each perpendicular axis	
10	Vibration Test (non-operating)	- 5Hz to 200Hz logarithm sweep for 20min/cycle. - 5Hz to 12.2Hz:The amplitude is 10 mm p-p. - 12.2Hz to 100Hz:The acceleration is 3.0G 0-pk. - 101Hz to 200Hz:The acceleration is 1.5G 0-pk. - 3 axes, 18 sweeps per axis	
11	Vibration Test Temperature Cycle	-10Hz to 1000Hz, 20.9G, -40°C~70°C - 8H×3Cycle	

• Ta ; Ambient Temperature

Notes :

1. In the Reliability Test, Confirm performance after leaving in room temp(25°C)
2. In the standard condition, there shall be no practical problems that may affect the display function 24 hours later after reliability test.

**Product Specifications****9. International Standards****9-1. Safety**

- a) UL 60950-1, Second Edition, Underwriters Laboratories Inc.  
Information Technology Equipment - Safety - Part 1 : General Requirements.
- b) CAN/CSA C22.2 No.60950-1-07, Second Edition, Canadian Standards Association.  
Information Technology Equipment - Safety - Part 1 : General Requirements.
- c) EN 60950-1:2006 + A11:2009, European Committee for Electrotechnical Standardization (CENELEC).  
Information Technology Equipment - Safety - Part 1 : General Requirements.

**9-2. Environment**

- a) RoHS, Directive 2002/95/EC of the European Parliament and of the council of 27 January 2003

## Product Specifications

### 10. Packing

#### 10-1. Designation of Lot Mark

a) Lot Mark

A	B	C	D	E	F	G	H	I	J	K	L	M
---	---	---	---	---	---	---	---	---	---	---	---	---

A,B,C : SIZE(INCH)  
 E : MONTH

D : YEAR  
 F ~ M : SERIAL NO.

Note

1. YEAR

Year	2001 2011	2002 2012	2003 2013	2004 2014	2005 2015	2006 2016	2007 2017	2008 2018	2009 2019	2010 2020
Mark	1	2	3	4	5	6	7	8	9	0

2. MONTH

Month	Jan	Feb	Mar	Apr	May	Jun	Jul	Aug	Sep	Oct	Nov	Dec
Mark	1	2	3	4	5	6	7	8	9	A	B	C

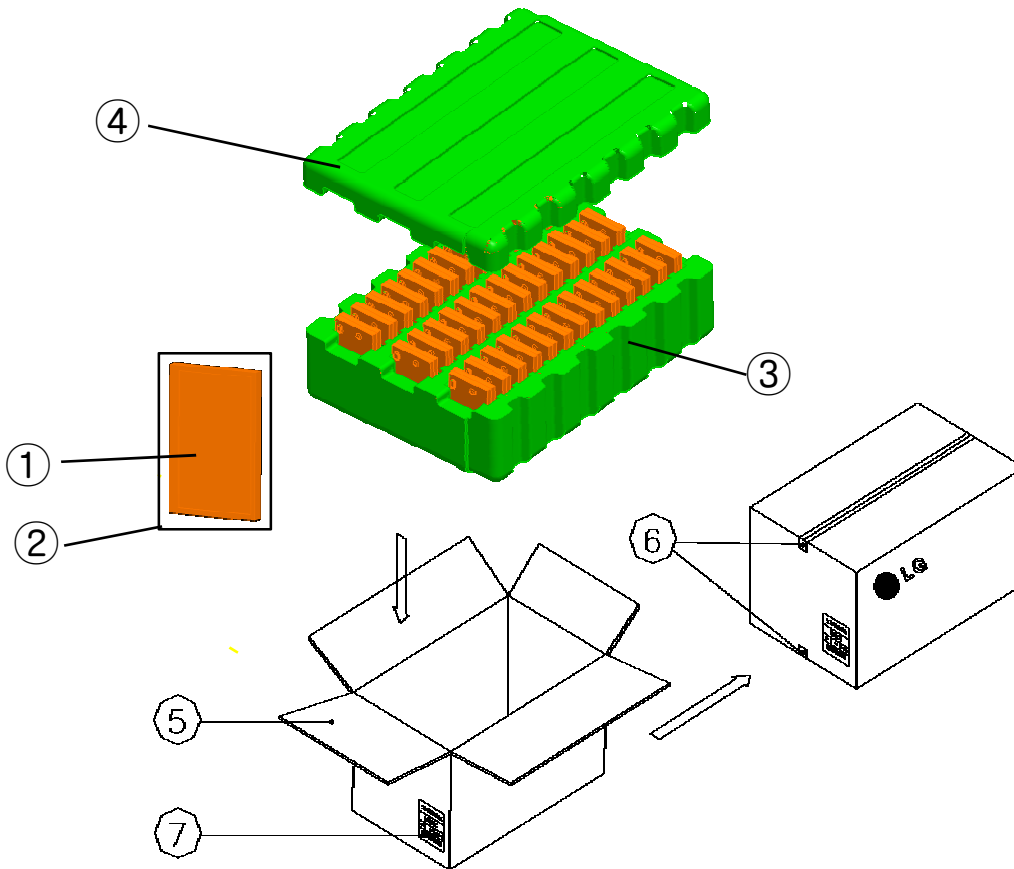
b) Location of Lot Mark

Serial No. is printed on the label. The label is attached to the backside of the LCD module.  
 This is subject to change without prior notice.

**Product Specifications**

**10-2. Packing Form**

- a) Package quantity in one box : 78 pcs
- b) Box Size : 475 x 348 x 175 (mm)



NO.	Description	Material
1	Module	78pcs/1 Box
2	Bag	PE,130x108
3	Packing, Bottom	EPP
4	Packing, Top	EPP
5	Carton Box	SWR4, 475X348X175
6	Tape	OPP 70MMx300m
7	Label	YUPO Paper 100x70

## Product Specifications

### **11. PRECAUTIONS**

Please pay attention to the following when you use this TFT LCD module.

#### **11-1. MOUNTING PRECAUTIONS**

- (1) You must mount a module using holes arranged in four corners or four sides.
- (2) You should consider the mounting structure so that uneven force(ex. Twisted stress) is not applied to the module.  
And the case on which a module is mounted should have sufficient strength so that external forces are not transmitted directly to the module.
- (3) Please attach a transparent protective plate to the surface in order to protect the polarizer.  
Transparent protective plate should have sufficient strength in order to the resist external forces.
- (4) You should adopt radiation structure to satisfy the temperature specification.
- (5) Acetic acid type and chlorine type materials for the cover case are not desirable because the former generates corrosive gas of attacking the polarizer at high temperature and the latter causes circuit break by electro-chemical reaction.
- (6) Do not touch, push or rub the exposed polarizers with glass, tweezers or anything harder than HB pencil lead. And please do not rub with dust clothes with chemical treatment.  
Do not touch the surface of polarizer for bare hand or greasy cloth.(Some cosmetics deteriorate the polarizer.)
- (7) When the surface becomes dusty, please wipe gently with absorbent cotton or other soft materials like chamois soaks with a small amount of Ethanol.
- (8) Wipe off saliva or water drops as soon as possible. Their long time contact with polarizer causes deformations and color fading.
- (9) Do not open the case because inside circuits do not have sufficient strength.
- (10) The metal case of a module should be contacted to electrical ground of your system.

#### **11-2. OPERATING PRECAUTIONS**

- (1) Response time depends on the temperature.(In lower temperature, it becomes longer.)
- (2) Brightness depends on the temperature. (In higher temperature, it becomes lower.)
- (3) Be careful for condensation at sudden temperature change. Condensation makes damage to polarizer or electrically contacted parts. And after fading condensation, smear or spot will occur.
- (4) When fixed patterns are displayed for a long time, remnant image is likely to occur.
- (5) Module has high frequency circuits. Sufficient suppression to the electromagnetic interference shall be done by system manufacturers. Grounding and shielding methods may be important to minimize the interference.

## Product Specifications

### 11-3. ELECTROSTATIC DISCHARGE CONTROL

Since a module is composed of electronic circuits, it is not strong to electrostatic discharge. Make certain that handling persons are connected to ground through wrist band etc. And don't touch interface pin directly.

### 11-4. PRECAUTIONS FOR STRONG LIGHT EXPOSURE

Strong light exposure causes degradation of polarizer and color filter.

### 11-5. STORAGE

When storing modules as spares for a long time, the following precautions are necessary.

- (1) Store them in a dark place. Do not expose the module to sunlight or fluorescent light. Keep the temperature between 5°C and 35°C at normal humidity.
- (2) The polarizer surface should not come in contact with any other object.  
It is recommended that they be stored in the container in which they were shipped.

### 11-6. HANDLING PRECAUTIONS FOR PROTECTION FILM

- (1) When the protection film is peeled off, static electricity is generated between the film and polarizer. This should be peeled off slowly (more than 3 seconds) and carefully by people who are electrically grounded and with well ion-blown equipment or in such a condition, etc.
- (2) The protection film is attached to the polarizer with a small amount of glue. If some stress is applied to rub the protection film against the polarizer during the time you peel off the film, the glue is apt to remain on the polarizer.  
Please carefully peel off the protection film without rubbing it against the polarizer.
- (3) When the module with protection film attached is stored for a long time, sometimes there remains a very small amount of glue still on the polarizer after the protection film is peeled off.
- (4) You can remove the glue easily. When the glue remains on the polarizer surface or its vestige is recognized, please wipe them off with absorbent cotton waste or other soft material like chamois soaked with a small amount of Ethanol.

## Contents

Revision Status .....	3
1.0. Introduction	
1.1. Scope .....	4
1.2. Incoming Inspection Right .....	4
1.3. Handling Precautions .....	4
2.0. Generals	
2.1. Sampling Method .....	5
2.2. Acceptable Quality Level(AQL) .....	5
2.3. Classification of defects .....	5
2.4. Determination of acceptability and subsequent disposal .....	5
2.5. Inspection Conditions .....	6
3.0. Inspection Criteria	
3.1. Dot Defect .....	7
3.2. Polarizer Defect .....	8
3.3. Foreign Material .....	9
3.4. Mura .....	9
3.5. LCM Appearance .....	10
3.6. Line Defect .....	12
3.7. Others .....	12
4.0. RMAs	
4.1. Verification .....	13
4.2. Supplier Induced Defects .....	13
4.3. Customer Induced Defects .....	13
5.0. Warranty	
5.1. Warranty Period .....	14
5.2. Repair Warranty .....	14
5.3. Warranty avoidance .....	14
6.0. Others .....	14
Appendix A .....	15

1.0 Nov/02/'10									
-------------------	--	--	--	--	--	--	--	--	--

## Revision Status

Rev. No.	Chapter	Contents	Date	Issued & amended by
1.0	All	Originated IIS	02/ Nov/ 2010	S.J. Kwon

1.0 Nov/02/'10									
-------------------	--	--	--	--	--	--	--	--	--

## 1.0 Introduction

---

### 1.1. Scope

This Incoming Inspection Standard shall be applied to TFT-LCD modules (hereafter called the "LCMs") supplied by LG Display (hereafter called the "Supplier") to its Customer.

### 1.2. Incoming inspection Right

The Customer shall have the right to conduct at its own cost and expense, an incoming inspection of the LCMs at the destination specified in the relevant B/L(Bills of Lading) in accordance with the LCM's specifications separately agreed upon and the inspection criteria set forth in this article.

The Customer shall notify the Supplier in writing of the inspection results (accept or reject) in accordance with the said Incoming Inspection Standard within 40 days from the date of the B/L.

Should the Customer fail to notify the results to Supplier within 40 days period, the right to reject the LCMs shall then lapse, and the said LCMs shall be deemed to have been accepted by the Customer.

### 1.3. Handling Precautions

- LCM Devices are made of fragile material such as Glass and plastic and may be broken or cracked if dropped it, so **PLEASE** handle them with care.
- **DO NOT** press the area covered with PET or such materials. These are weak point of LCMs since of TCPs(Driver ICs) and PWBs.
- **PLEASE** support the Bezel with your finger when connecting the interface cable.
- Please **DO NOT** touch the surface of the Glass(Polarizer).
- **PLEASE** wear the Wrist Strap when handling.  
Semiconductive devices are included in the LCMs and they should be handled with care to prevent any electrostatic discharge(ESD).
- **PLEASE** keep the LCMs in the specified, original packing boxes when storage.
- **DO NOT** stack the LCMs too high without wrapping material such as AIR CAP.
- Before using the LCMs, **PLEASE** check the Engineering specification.
- LCMs contain a small amount of Liquid Crystal and Mercury. **PLEASE** follow local ordinances or regulations for disposal.

1.0 Nov/02/'10									
-------------------	--	--	--	--	--	--	--	--	--

## 2.0 Generals

### 2.1. Sampling Method

Unless otherwise agreed upon in writing, the sampling inspection shall be applied to the Customer's incoming inspection.

- 2.1.1. Lot size : Quantity per shipment lot (minimum lot size : 100 pieces)
- 2.1.2. Sampling type : Normal inspection, Single sampling
- 2.1.3. Inspection level : II
- 2.1.4. Sampling table : ANSI Z1.4

### 2.2. Acceptable Quality Level(AQL)

The AQL for major and minor defects shall be respectively set forth below.

- 2.2.1. **Major = 0.65 %**
- 2.2.2. **Minor = 1.5 %**

### 2.3. Classification of defects

Defects are classified as either a major defect or a minor defect based on the degree of defect defined herein.

#### 2.2.1. Major defect

The major defect is a defect that is likely to result in product failure, or reduction in the product's intended usage.

#### 2.2.2. Minor defect

The minor defect is a defect that has little bearing on the effective use or operation of the product.

Specific criteria of judgment of major and/or minor defects or other related issues shall be in accordance with the Appendix A, "Classification of Defects".

### 2.4. Determination of acceptability and subsequent disposal

If the number of defects found in the LCM sampling lot is equal to or less than the AQL(Acceptable Quality Level), the lot shall be accepted.

If the number of defects found in the LCM sampling lot is greater than the AQL, the lot shall be rejected. The Customer shall inform the Supplier of the results of such inspection detailly within the time period stipulated in chapter 1.2. "Incoming inspection Right".

1.0 Nov/02/'10									
-------------------	--	--	--	--	--	--	--	--	--

2.4.1. Accepted lot

An acceptance under the above incoming inspection shall constitute an acceptance by the Customer of such lot of the LCMs in terms of the landed quality thereof.

2.4.2. Rejected lot

If a shipment lot of products is rejected under the above incoming inspection due to any defects of which the Supplier is responsible and such a fact is clearly confirmed by the Supplier through a separate inspection or as otherwise decided, the Supplier shall choose one of the following three options which must be determined by mutual consent.

The Supplier shall advise the Customer of its choice not later than 10 working days(Monday through Friday) of receipt of the "Customer's notification of rejected lot" :

- a. The Customer shall return the rejected lot to the place to be designated by the Supplier and the Supplier shall screen all of the products in the lot and repair or replace the defective LCMs.
- b. The Supplier shall screen all of the LCMs in the lot and repair or replace the defective LCMs within a reasonable time period at the Customer's facility.
- c. The Customer shall screen the entire lot of LCMs at the expense of Supplier's, and the expense must be agreed by the Supplier. The rejected LCMs shall be returned to the place designated by the Supplier.

2.5. Inspection Conditions

Viewing Distance	30~40cm		
Ambient illumination	Operating Inspection	50~150 lux	
	Visual Inspection	300~700 lux	
Viewing angle	Within 30 degrees left, right, up and down as the right picture shown		
Ambient temperature	23±3°C		
Display patterns	R, G, B, Black, Half Gray, White		
Inspection zone	Active area which is operating with pixels.		
ND Filter	Viewing angle	90±5 °	
	Distance	30~40cm	
1.0 Nov/02/'10			

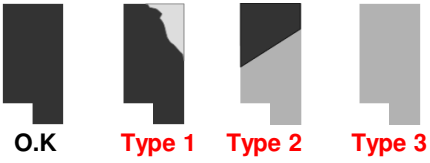
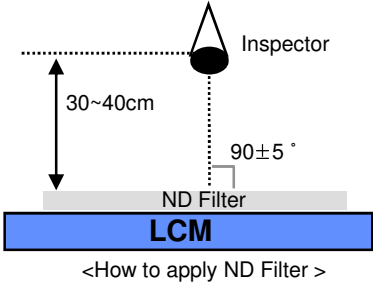
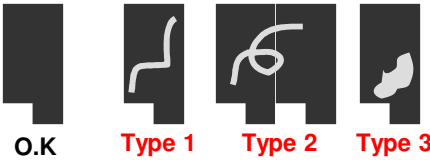
### 3.0 Inspection Criteria

#### 3.1. Dot Defects

##### 3.1.1. Bright Dots

Dots(sub-pixels) which appear bright in the screen when the LCM operates with Black pattern. (Including bright dots caused by foreign material)

Items		Criteria (acceptable level)	
Bright Dots	R,G or B 1 dot	$N \leq 0$	It would not be counted as a bright dot when Dot is not visible using <b>2.0% ND Filter</b> , although it is visible with naked eyes
	Adjacent 2 dots	$N \leq 0$	
	Minimum distance	disregarded	
	Density	$N \leq 0$	
	total	$N \leq 0$	

Defect Modes	Bright dot types	Inspection standards
C/F damage, Domain, Foreign material in Panel		<ul style="list-style-type: none"> <li>• Inspection Patterns : Black, R, G, B</li> <li>• ND Filter</li> </ul> 
Foreign material in POL, POL bubble		

##### 3.1.2. Dark Dots

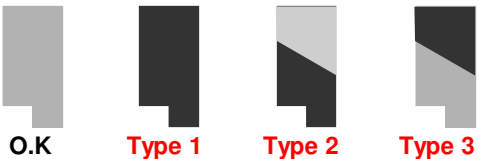
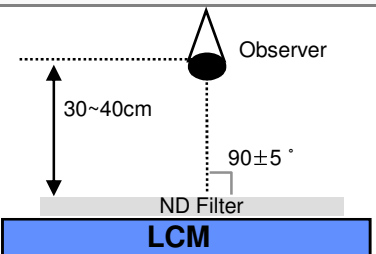
Dots(sub-pixels) which appear dark in the screen when the LCM operates with White or Half Gray patterns.

Items		Criteria (acceptable level)	
Dark Dots	1 dot	$N \leq 2$	It would not be counted as a dark dot when Dot is not visible using <b>5% ND Filter</b> , although it is visible with naked eyes
	Adjacent 2 dots	$N \leq 1$	
	Minimum distance	$L \geq 10\text{mm}$	
	total	$N \leq 3$	

1.0 Nov/02/'10								
-------------------	--	--	--	--	--	--	--	--

### 3.0 Inspection Criteria

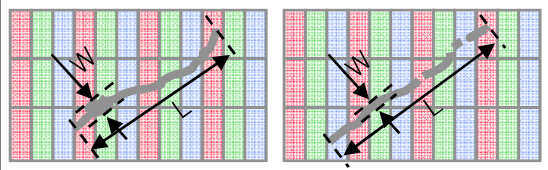
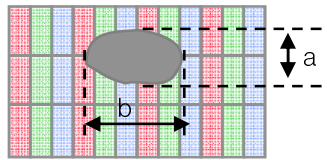
#### 3.1.2. Dark Dot

Defect Modes	Dark Dot types	Inspection standards
Pixel off	 <p>O.K. Type 1 Type 2 Type 3</p>	<ul style="list-style-type: none"> <li>• Inspection Patterns : White, Half ray</li> <li>• ND Filter</li> </ul>  <p>&lt;How to apply ND Filter&gt;</p>

#### 3.2. Polarizer Defects

Items		Criteria(acceptable level)	
Scratches	Linear	Width	$0.05 \leq W \leq 0.3$
		Length	$0.1 \leq L \leq 5.0$
		Quantity	$N \leq 3$
Dent or Bubble	Circular	Diameter	$0.1 \leq D \leq 0.3$
		Quantity	$N \leq 3$

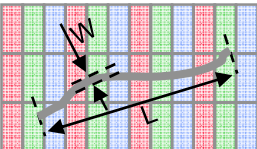
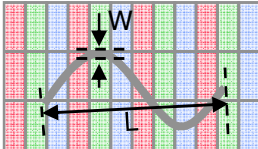
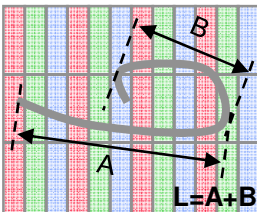
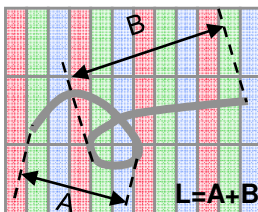
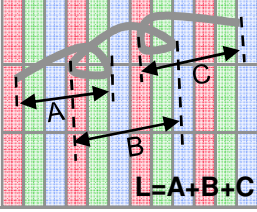
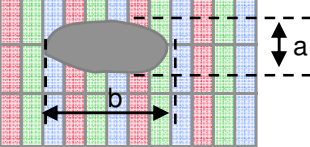
1. Extraneous substance which can be wiped out, like Finger Print, Particles, are not considered as a defect.  
 2. Defects which are on the Black Matrix(outside of Active Area) are not considered as a defect.

Defect modes	Definition	Inspection standards
Scratches		<ul style="list-style-type: none"> <li>• Inspection patterns : White, Half Gray</li> </ul> <p><math>L &gt; 4W</math> : considered as Linear  <math>L \leq 4W</math> : considered as Circular</p> <p>W : widest point [mm]                      L : longest point [mm]</p> <p><math>D = (a+b)/2</math></p>
Dent or Bubble		

1.0 Nov/02/'10								
-------------------	--	--	--	--	--	--	--	--

### 3.3 Foreign Material (Polarizer, Backlight)

Items		Criteria(acceptable level)	
Linear	Width	$0.05 \leq W \leq 0.3$	In the case of foreign material in Polarizer which appears bright, it is based on inspection standards of Bright Dot. (ND Filter)
	Length	$0.1 \leq L \leq 5.0$	
	Quantity	$N \leq 3$	
Circular	Diameter	$0.1 \leq D \leq 0.3$	
	Quantity	$N \leq 2$	

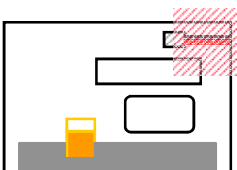
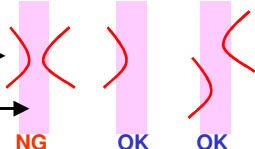
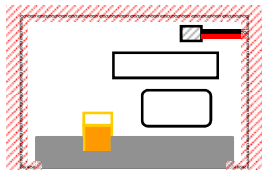
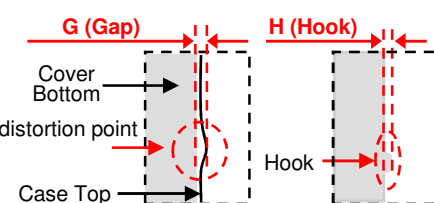
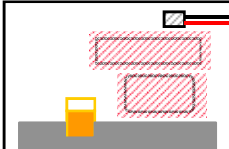

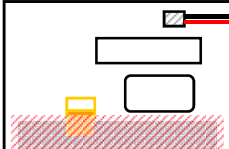
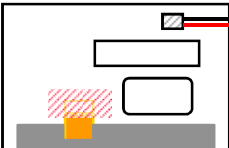
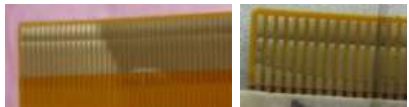
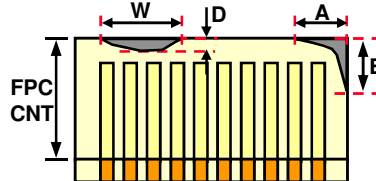
Defect modes	Definition	Inspection standards
Linear	 	<p><math>L &gt; 4W</math> : considered as Linear  <math>L \leq 4W</math> : considered as Circular</p> <p>W : widest point [mm]                      L : longest point [mm]</p> <p><math>D = (a+b)/2</math></p> <p>• Inspection Pattern :  <b>White, Half Gray</b></p>
	 	
		
Circular		

### 3.4 Mura

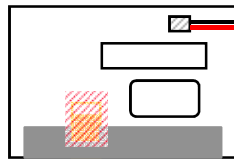
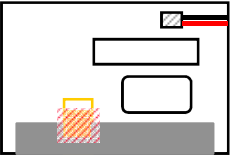
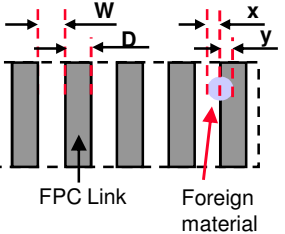
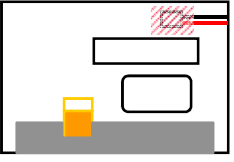
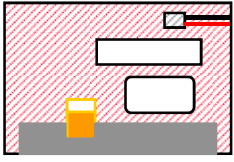
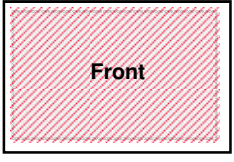

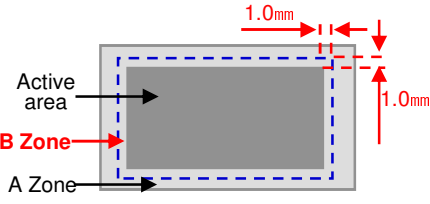
Mura which appears in the screen when the LCM displayed. **(Using 1% ND Filter)**  
 It would not be counted as Mura, although it is visible with naked eyes

1.0 Nov/02/'10									
-------------------	--	--	--	--	--	--	--	--	--

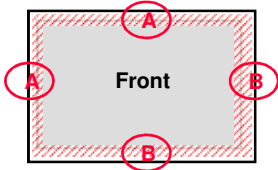
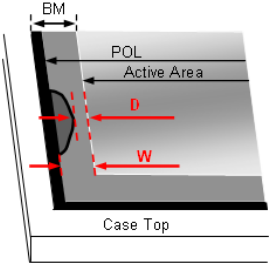
### 3.5. LCM Appearance

Items	Specifications	Acceptable Number	Remark
<p>Wire</p> 	<ul style="list-style-type: none"> <li>• <b>Wire Pressed</b></li> </ul>  <p>Pressed points →</p> <p>Wire →</p> <p>NG OK OK</p> <ul style="list-style-type: none"> <li>• <b>Wire Scratch</b></li> <li>: Wire exposure is not allowed</li> </ul>	disregarded	
<p>Case Top</p> 	<ul style="list-style-type: none"> <li>• <b>Case Top Hook must be fully locked.</b></li> <li>• <b>Partial distortion</b></li> <li>: <math>G &lt; H</math></li> </ul>  <p><math>G</math> (Gap) <math>H</math> (Hook)</p> <p>Cover Bottom →</p> <p>distortion point →</p> <p>Case Top →</p> <p>Hook →</p>	disregarded	<p>G : Gap between Cover Bottom and Case Top (or Gap between Cover Bottom and Support Main)</p> <p>H : Height of Hook</p>
<p>Label</p> 	<ul style="list-style-type: none"> <li>• <b>Although label printing is not clear, it is acceptable if scanners can read label information.</b></li> </ul> 	disregarded	
<p>Adhesive Tape</p> 	<ul style="list-style-type: none"> <li>• <b>Although Adhesive Tape has Dent or Scratch and is pressed, it is acceptable if FPC is not exposed.</b></li> </ul>	disregarded	
<p>FPC</p> 	<ul style="list-style-type: none"> <li>• <b>FPC copper damage (ex. dent, dirt ..etc) is acceptable if function/operation of LCM is in normal.</b></li> </ul>  <p>OK OK</p> <ul style="list-style-type: none"> <li>• <b>Spec for FPC terminal</b></li> <li>1) <math>W \leq 10.0\text{mm}</math>, <math>B \leq 0.5\text{mm}</math></li> <li>2) <math>A \leq 1.5\text{mm}</math>, <math>B \leq 1.0\text{mm}</math></li> </ul>  <p>FPC CNT</p> <p>W D A B</p>	disregarded	

1.0  
Nov/02/'10

Items	Specifications	Acceptable Number	Remark
<p>FPC</p> 	<ul style="list-style-type: none"> <li>• <b>FPC Pad area</b> 1) It is acceptable if it is wiped down.</li> <li>• <b>FPC non-Pad area</b> 1) It is O.K if it does not affect function/operation of LCM 2) It is O.K if customers do not have any problems during assembly.</li> </ul>	disregarded	
<p>FPC</p> 	<ul style="list-style-type: none"> <li>• Wrinkles, Crease, Dent, Being pressed 1) Copper exposure is not allowed 2) It is O.K if it does not affect function/operation of LCM.</li> <li>• <b>Damage and Dirt on Link pad area</b> 1) Copper exposure is not allowed 2) <math>x &lt; 2/3W</math>, <math>y &lt; 2/3W</math></li> </ul>	disregarded	
<p>Wire CNT</p> 	<ul style="list-style-type: none"> <li>• <b>Dent, Scratch</b> 1) It is O.K if it does not affect Connector insertion.</li> </ul>	disregarded	
<p>Cover Shield</p> 	<ul style="list-style-type: none"> <li>• <b>Discoloration, Scratch, Dent</b> : It is O.K if it is not over 50% of the whole area.</li> <li>• <b>It is O.K if it does not affect function/operation of LCM.</b></li> </ul>	disregarded	
<p>POL</p> 	<ul style="list-style-type: none"> <li>• <b>It is O.K if it is wiped up.</b> : It could be cleaned by rubbing</li> </ul>	disregarded	
<p>Case Top</p> 	<ul style="list-style-type: none"> <li>• <b>Scratch, Dent and Distortion in the B zone are not allowed.</b></li> </ul> 	disregarded	

1.0									
Nov/02/'10									

Items	Specifications	Acceptable Number	Remark
<p>POL [Polarizer] edges looseness : Not firmly attached.</p>  <p>POL</p>	<ul style="list-style-type: none"> <li>• <b>Upper Polarizer</b> <ol style="list-style-type: none"> <li>1) Over 5.0 inch Model : A area -&gt; <math>D &lt; 0.5\text{mm}</math> B area -&gt; <math>D &lt; 0.5\text{mm}</math></li> <li>2) 5.0 inch or under 5.0 inch Model : A area -&gt; <math>D &lt; 0.3\text{mm}</math> B area -&gt; <math>D &lt; 0.3\text{mm}</math></li> </ol> </li> <li>* Based on CAS, if <math>W \leq 10\text{mm}</math>, <math>D &lt; 0.1\text{mm}</math></li> <li>• <b>Lower Polarizer</b> : It is O.K if it does not affect function/operation of LCM.</li> <li>* Bezel Open and Close Type have the same inspection standards.</li> </ul>	<p>disregarded</p>	 <ul style="list-style-type: none"> <li>* In the case of Bezel Close, <math>W = \text{BM}</math> [Black Matrix]</li> <li>* <math>D = (a+b)/2</math></li> </ul>

### 3.6. Line Defect

All kinds of line defects such as vertical, horizontal or cross are not allowed.

### 3.7. Others

Issues which are not defined in this criteria shall be discussed with both parties, Customer and Supplier, for better solution.

1.0 Nov/02/'10									
-------------------	--	--	--	--	--	--	--	--	--

## 4.0 RMAs

---

### 4.1. Verification

The Supplier can verify the defective LCMs to segregate the responsibilities at Customer's facility or can request the Customer to ship the defective LCMs to assigned place for verification

This verification result shall be agreed mutually by the Customer and Supplier. This result can be corrected/changed after detail failure analysis at Supplier's facilities.

### 4.2. Supplier Induced Defects

All of the Supplier induced defective LCMs shall be returned to the Supplier for repair or replacement.

Before return the defective LCMs, the Customer needs Supplier's confirmation with RMA Number.

All of the returned LCMs shall be returned to the Customer within agreed time period.

### 4.3. Customer Induced Defects

The Customer can return the customer induced defective LCMs to the Supplier for repair.

The repair cost for Customer induced defective LCMs shall be agreed with both parties, Customer and Supplier.

1.0 Nov/02/'10									
-------------------	--	--	--	--	--	--	--	--	--

## 5.0 Warranty

---

### 5.1. Warranty Period

In-warranty period is **Eighteen(18)** Months from manufacturing month of LCM.

Note)

- a. Eighteen months are composed of twelfth months in-warranty period and sixth months distribution period.
- b. The manufacturing Month is on the LCMs as Supplier's serial No.
- c. If customer want to extend warranty, customer should pay 0.5% of a unit cost per 6months.

### 5.2. Repair Warranty

Repair warranty is **Twelve(12)** Months from repaired month for repaired LCMs.

Note) The Label for repair will be added after repairing.

### 5.3. Warranty avoidance

The warranty will be avoided in cases of below,

- a. When the warranty period is expired
- b. The Customer induced defective LCMs
- c. When the LCMs were repaired by 3rd party without Supplier's approval.
- d. When the LCMs were treated like Disassemble and Rework by the Customer and/or Customer's representatives without Supplier's approval.

## 6. Others

If any problems arise with the LCMs supplied by supplier, the Customer and Supplier will cooperate and make efforts to solve it with mutual confidence and respect.

---

1.0 Nov/02/'10									
-------------------	--	--	--	--	--	--	--	--	--

**Appendix A. Classification of Defects**

Defect Mode	Criterion for Defect	Class
Operating Frequency	Specified range in the CAS	Major
Power Consumption	Specified range in the CAS	Major
Contrast Ratio	Specified range in the CAS	Major
Line Defect	Not allowed any Vertical, Horizontal, and Cross line	Major
Polarizer Defects	Shall be accordance with the item 3.0 "Inspection Criteria" in this standard	Minor
Extraneous Substance	Shall be accordance with the item 3.0 "Inspection Criteria" in this standard	Minor
Dot Defect	Shall be accordance with the item 3.0 "Inspection Criteria" in this standard	Minor
Bezel Claw Forming	The bezel claw is not formed sufficiently	Minor

1.0 Nov/02/'10									
-------------------	--	--	--	--	--	--	--	--	--