

TFT-Display Datenblatt

Modell LC470WUN-SAA1

Kurzdaten

Hersteller	LG Display
Diagonale	47,0" / 119,4cm
Format	16:9
Auflösung	1920x1080
Backlight	CCFL/500cd/m ²
Temperatur	0...+50°C (Betrieb)

SPECIFICATION FOR APPROVAL

- () Preliminary Specification
(●) Final Specification

Title	47.0" WUXGA TFT LCD
-------	---------------------

BUYER	
MODEL	

SUPPLIER	LG.Philips LCD Co., Ltd.
*MODEL	LC470WUN
SUFFIX	SAA1 (RoHS Verified)

*When you obtain standard approval,
please use the above model name without suffix

APPROVED BY	SIGNATURE DATE
/	
/	
/	

Please return 1 copy for your confirmation with
your signature and comments.

APPROVED BY	SIGNATURE DATE
J.H. Yoon /Senior Manager	
REVIEWED BY	
P.Y. Kim / Manager	
PREPARED BY	
Y.N. Lee / Engineer	

TV Product Development Dept.
LG. Philips LCD Co., Ltd

Product Specification

CONTENTS

Number	ITEM	Page
	COVER	1
	CONTENTS	2
	RECORD OF REVISIONS	3
1	GENERAL DESCRIPTION	4
2	ABSOLUTE MAXIMUM RATINGS	5
3	ELECTRICAL SPECIFICATIONS	6
3-1	ELECTRICAL CHARACTERISTICS	6
3-2	INTERFACE CONNECTIONS	8
3-3	SIGNAL TIMING SPECIFICATIONS	10
3-4	SIGNAL TIMING WAVEFORMS	11
3-5	COLOR DATA REFERENCE	12
3-6	POWER SEQUENCE	13
4	OPTICAL SPECIFICATIONS	15
5	MECHANICAL CHARACTERISTICS	19
6	RELIABILITY	22
7	INTERNATIONAL STANDARDS	23
7-1	SAFETY	23
7-2	EMC	23
8	PACKING	24
8-1	DESIGNATION OF LOT MARK	24
8-2	PACKING FORM	24
9	PRECAUTIONS	25
9-1	MOUNTING PRECAUTIONS	25
9-2	OPERATING PRECAUTIONS	25
9-3	ELECTROSTATIC DISCHARGE CONTROL	26
9-4	PRECAUTIONS FOR STRONG LIGHT EXPOSURE	26
9-5	STORAGE	26
9-6	HANDLING PRECAUTIONS FOR PROTECTION FILM	26

Product Specification

1. General Description

The LC470WUN is a Color Active Matrix Liquid Crystal Display with an integral Cold Cathode Fluorescent Lamp(CCFL) backlight system. The matrix employs a-Si Thin Film Transistor as the active element. It is a transmissive display type which is operating in the normally black mode. It has a 46.96 inch diagonally measured active display area with WUXGA resolution (1080 vertical by 1920 horizontal pixel array). Each pixel is divided into Red, Green and Blue sub-pixels or dots which are arrayed in vertical stripes. Gray scale or the luminance of the sub-pixel color is determined with a 10-bit gray scale signal for each dot. Therefore, it can present a palette of more than 1.07 Billion colors.

It has been designed to apply the 10-bit 2-port LVDS interface.

It is intended to support LCD TV, PCTV where high brightness, super wide viewing angle, high color gamut, high color depth and fast response time are important.

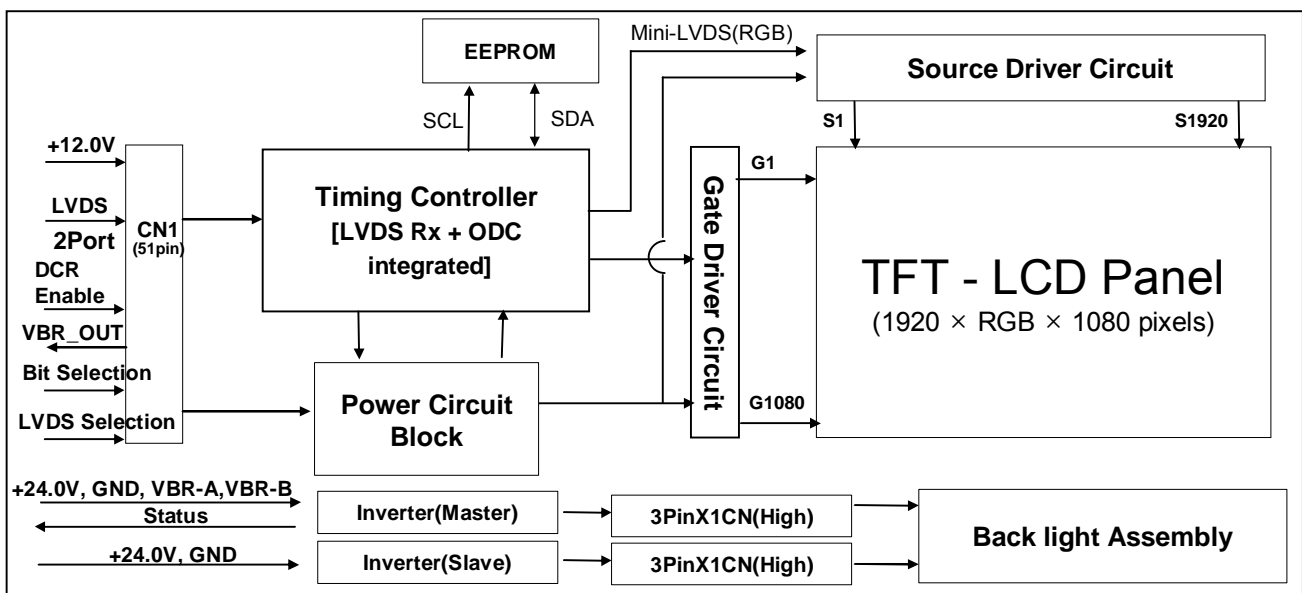

General Features

Active Screen Size	46.96 inch (1192.87mm) diagonal
Outline Dimension	1096.0(H) x 640.0 (V) x 51 mm(D) (Typ.)
Pixel Pitch	0.5415 mm x 0.5415 mm
Pixel Format	1920 horiz. by 1080 vert. Pixels, RGB stripe arrangement
Color Depth	10Bit (D), 1.07 Billion colors
Luminance, White	500 cd/m ² (Center 1point ,Typ.)
Viewing Angle (CR>10)	Viewing angle free (R/L 178 (Min.), U/D 178 (Min.))
Power Consumption	Total 220.08 W (Typ.) [Logic=7.08W, Backlight=213W (V _{BR-A} =1.65V)]
Weight	14.5 Kg (Typ.)
Display Mode	Transmissive mode, Normally black
Surface Treatment	Hard coating(3H), Anti-glare treatment of the front polarizer (Haze 13%)

Product Specification

2. Absolute Maximum Ratings

The following items are maximum values which, if exceeded, may cause faulty operation or damage to the LCD module.

Table 1. ABSOLUTE MAXIMUM RATINGS

Parameter		Symbol	Value		Unit	Remark
			Min	Max		
Power Input Voltage	LCM	V _{LCD}	-0.3	+14.0	V _{DC}	at 25 ± 2 °C
	Backlight inverter	V _{BL}	-0.3	+27.0	V _{DC}	
ON/OFF Control Voltage		V _{ON/OFF}	-0.3	+5.5	V _{DC}	
Brightness Control Voltage		V _{BR}	0	+5.0	V _{DC}	
Operating Temperature		T _{OP}	0	+50	°C	Note 1,2
Storage Temperature		T _{ST}	-20	+60	°C	
Operating Ambient Humidity		H _{OP}	10	90	%RH	
Storage Humidity		H _{ST}	10	90	%RH	

- Notes : 1. Temperature and relative humidity range are shown in the figure below.
Wet bulb temperature should be 39 °C Max. and no condensation of water.
2. Gravity mura can be guaranteed under 40 °C condition.

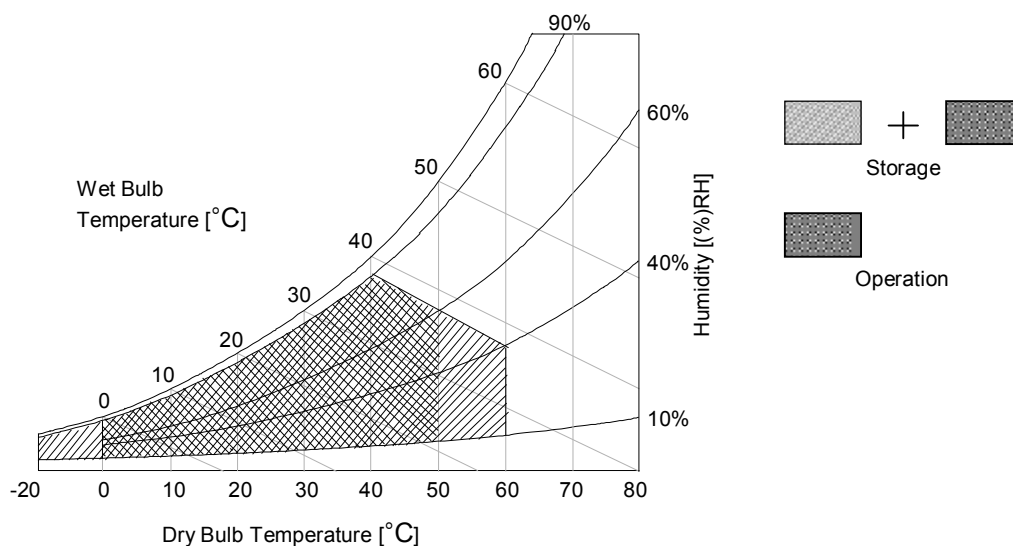

Product Specification

3. Electrical Specifications**3-1. Electrical Characteristics**

It requires two power inputs. One is employed to power for the LCD circuit. The other is used for the CCFL backlight and inverter circuit.

Table 2. ELECTRICAL CHARACTERISTICS

Parameter	Symbol	Value			Unit	Note
		Min	Typ	Max		
Circuit :						
Power Input Voltage	V_{LCD}	11.4	12.0	12.6	V_{DC}	
Power Input Current	I_{LCD}	410	590	770	mA	1
		580	830	1080	mA	2
Power Consumption	P_{LCD}	-	7.08	9.24	Watt	1
Rush current	I_{RUSH}	-	-	5	A	3

Notes: 1. The specified current and power consumption are under the $V_{LCD}=12.0V$, $25 \pm 2^{\circ}C$, $f_V=60Hz$ condition whereas mosaic pattern(8 x 6) is displayed and f_V is the frame frequency.

2. The current is specified at maximum current pattern.

3. The duration of rush current is about 2ms and rising time of power input is 0.5ms (min.).

White : 1023Gray
Black : 0Gray

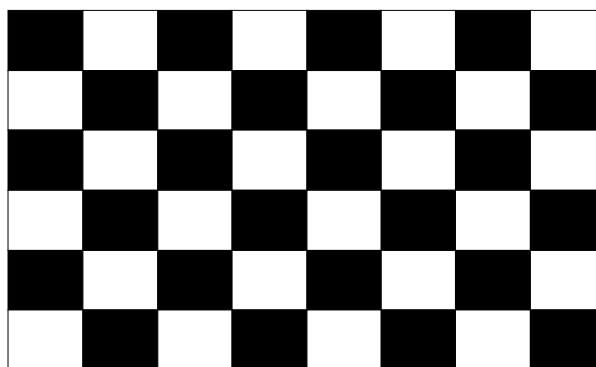

Mosaic Pattern(8 x 6)

Product Specification

Table 3. ELECTRICAL CHARACTERISTICS (Continue)

Parameter		Symbol	Values			Unit	Notes	
			Min	Typ	Max			
Inverter :								
Power Supply Input Voltage		VBL	22.8	24.0	25.2	Vdc	1	
Power Supply Input Voltage Ripple			-	-	0.5	Vp-p	1	
Power Supply Input Current	After Aging	IBL_A	-	8.9	10.3	A	V _{BR-A} = 1.65V ... 1	
			-	10.0	11.0	A	V _{BR-A} = 3.3V ... 1	
	Before Aging	IBL_B	-	11.0	12.0	A	V _{BR-A} = 1.65V ... 2	
			-	12.0	13.0	A	V _{BR-A} = 3.3V ... 2	
Power Supply Input Current (In-Rush)		Irush	-	-	14.0	A	V _{BL} = 22.8V V _{BR-B} = 3.3V V _{BR-A} = 1.65V	
Power Consumption		PBL	-	213	250	W	V _{BR-A} = 1.65V ... 1	
Input Voltage for Control System Signals	Brightness Adjust		V _{BR-A}	0.0	1.65	3.3	Vdc	
	On/Off	On	V on	2.5	-	5.0	Vdc	
		Off	V off	-0.3	0.0	0.8	Vdc	
	Brightness Adjust		V _{BR-B}	0	-	3.3	V	
Lamp:								
Discharge Stabilization Time		Ts			3	min	3	
Life Time			50,000			Hrs	4	

Notes :

- Electrical characteristics are determined after the unit has been 'ON' and stable for approximately 120 minutes at 25±2°C. The specified current and power consumption are under the typical supply Input voltage 24V and V_{BR} (V_{BR-A} : 1.65V & V_{BR-B} :3.3V), it is total power consumption.
The ripple voltage of the power supply input voltage is under 0.5 Vp-p. LPL recommend Input Voltage is 24.0V ± 5%.
- Electrical characteristics are determined within 30 minutes at 25±2°C.
The specified currents are under the typical supply Input voltage 24V.
- The brightness of the lamp after lighted for 5minutes is defined as 100%.
TS is the time required for the brightness of the center of the lamp to be not less than 95% at typical current.
The screen of LCD module may be partially dark by the time the brightness of lamp is stable after turn on.
- Specified Values are for a single lamp which is aligned horizontally.
The life time is determined as the time which luminance of the lamp is 50% compared to that of initial value at the typical lamp current (V_{BR-A} : 1.65V & V_{BR-B} :3.3V), on condition of continuous operating at 25± 2°C
- The duration of rush current is about 10ms.

Product Specification

3-2. Interface Connections

This LCD module employs two kinds of interface connection, a 51-pin connector is used for the module electronics and Master 14-pin and Slave 12-pin connectors are used for the integral backlight system.

3-2-1. LCD Module

- LCD Connector(CN1): FI-RE51S-HF(manufactured by JAE) or Equivalent
- Mating Connector : FI-RE51HL(manufactured by JAE)

Table 4. MODULE CONNECTOR(CN1) PIN CONFIGURATION

No	Symbol	Description	No	Symbol	Description
1	GND	Ground	27	Bit Select	'H' = 10Bit (D)
2	NC	No Connection	28	RA2N	SECOND CHANNEL A-
3	NC	No Connection	29	RA2P	SECOND CHANNEL A+
4	NC	No Connection	30	RB2N	SECOND CHANNEL B-
5	NC	No Connection	31	RB2P	SECOND CHANNEL B+
6	NC	No Connection	32	RC2N	SECOND CHANNEL C-
7	LVDS Select	'H' = JEIDA , 'L' = VESA	33	RC2P	SECOND CHANNEL C+
8	VBR_EXT	External VBR	34	GND	Ground
9	VBR_OUT	VBR output	35	RCLK2N	SECOND CLOCK CHANNEL Clk-
10	DCR_Enable	'H' = Enable , 'L' = Disable	36	RCLK2P	SECOND CLOCK CHANNEL Clk+
11	GND	Ground	37	GND	Ground
12	RA1N	FIRST CHANNEL A-	38	RD2N	SECOND CHANNEL D-
13	RA1P	FIRST CHANNEL A+	39	RD2P	SECOND CHANNEL D+
14	RB1N	FIRST CHANNEL B-	40	RE2N	SECOND CHANNEL E-
15	RB1P	FIRST CHANNEL B+	41	RE2P	SECOND CHANNEL E+
16	RC1N	FIRST CHANNEL C-	42	GND	Ground
17	RC1P	FIRST CHANNEL C+	43	GND	Ground
18	GND	Ground	44	GND	Ground
19	RCLK1N	FIRST CLOCK CHANNEL Clk-	45	GND	Ground
20	RCLK1P	FIRST CLOCK CHANNEL Clk+	46	GND	Ground
21	GND	Ground	47	NC	No connection
22	RD1N	FIRST CHANNEL D-	48	VLCD	Power Supply +12.0V
23	RD1P	FIRST CHANNEL D+	49	VLCD	Power Supply +12.0V
24	RE1N	FIRST CHANNEL E-	50	VLCD	Power Supply +12.0V
25	RE1P	FIRST CHANNEL E+	51	VLCD	Power Supply +12.0V
26	GND	Ground	-	-	-

Notes :

1. The pin no 44 is LCD Test option. "AGP" (Auto Generation LCM operates Pattern) or "NSB" (No Signal Black) is case that LVDS signals are out of frequency or abnormal condition in spite of 12 volt power supply. LPL recommends "NSB". (AGP : "VCC" or "OPEN" / NSB : "GND")
2. All GND(ground) pins should be connected together to the LCD module's metal frame.
3. All VLCD (power input) pins should be connected together.
4. All Input levels of LVDS signals are based on the EIA 664 Standard.
5. Specific pins(pin No. #1~#10) are used for internal data process of the LCD module.
If not used, these pins are no connection.
6. If DCR function should be enable('H'), 10th pin must be connected to serial resistor which value is under 1k ohm.

Product Specification

3-2-2. Backlight Inverter

Master

-Inverter Connector : S14B-PH-SMC (JST)
or Equivalent

- Mating Connector : PHR-14 or Equivalent

Slave

-Inverter Connector : S12B-PH-SMC (JST)
or Equivalent

-Mating Connector : PHR-12 or Equivalent

Table 5. INVERTER CONNECTOR PIN CONFIGURATION

Pin No	Symbol	Description	Master	Slave	Note
1	VBL	Power Supply +24.0V	VBL	VBL	
2	VBL	Power Supply +24.0V	VBL	VBL	
3	VBL	Power Supply +24.0V	VBL	VBL	
4	VBL	Power Supply +24.0V	VBL	VBL	
5	VBL	Power Supply +24.0V	VBL	VBL	
6	GND	Backlight Ground	GND	GND	
7	GND	Backlight Ground	GND	GND	
8	GND	Backlight Ground	GND	GND	1
9	GND	Backlight Ground	GND	GND	
10	GND	Backlight Ground	GND	GND	
11	VBR-A	Analog dimming voltage DC 0.0V ~ 3.3V (Typ : 1.65V)	VBR-A	Don't care	2, 3
12	VON/OFF	0.0V ~ 5.0V	On/Off	Don't care	
13	VBR-B	Burst dimming voltage DC 0.0V ~ 3.3V	VBR-B	-	3
14	Status	Normal : Upper 3.0V Abnormal : Under 0.7V	Status	-	4

Notes : 1. GND should be connected to the LCD module's metal frame.

2. If Pin #11 is open, $V_{BR-A} = 1.65V$. When apply over 1.65V (~ 3.3V) continuously, its luminance is increasing however lamp's life time is decreasing.

It could be usable for boost up luminance when using DCR (=Dynamic contrast ratio) function only.

3. Minimum Brightness : $V_{BR-B} = 0V$ Maximum Brightness : $V_{BR-B} = 3.3V$

4. Even though Pin #14 is open, there is no effect on inverter operating, The output terminal of inverter.

5. Each impedance of pin #11,12 and 13 is 140[K Ω], 41[K Ω], 125[K Ω]

◆ Rear view of LCM

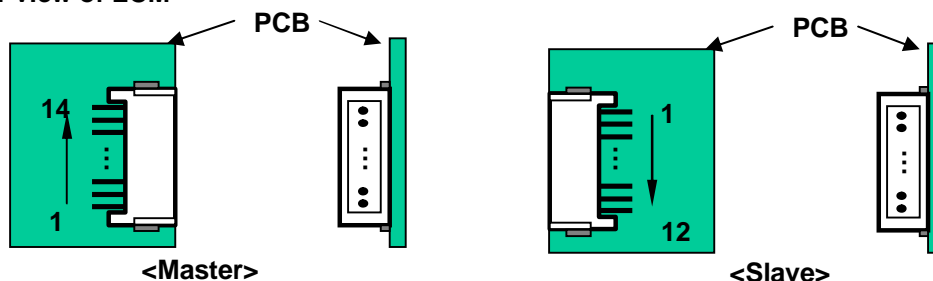

Product Specification

3-3. Signal Timing Specifications

Table 6 shows the signal timing required at the input of the LVDS transmitter. All of the interface signal timing should be satisfied with the following specification for normal operation.

Table 6. TIMING TABLE for NTSC (DE Only Mode)

ITEM		Symbol	Min	Typ	Max	Unit	Note
Horizontal	Display Period	t _{HV}	-	960	-	tclk	
	Blank	t _{HB}	72	140	320	tclk	
	Total	t _{HP}	1060	1100	1280	tclk	2200/2
Vertical	Display Period	t _{VV}	-	1080	-	Lines	
	Blank	t _{VB}	12	45	86	Lines	
	Total	t _{VP}	1090	1125	1166	Lines	
ITEM		Symbol	Min	Typ	Max	Unit	Note
Frequency	DCLK	f _{CLK}	70.5	74.25	78	MHz	148.5/2
	Horizontal	f _H	64.1	67.5	70.9	KHz	
	Vertical	f _V	57	60	63	Hz	

Table 7 shows the signal timing required at the input of the LVDS transmitter. All of the interface signal timing should be satisfied with the following specification for normal operation.

Table 7. TIMING TABLE for PAL (DE Only Mode)

ITEM		Symbol	Min	Typ	Max	Unit	Note
Horizontal	Display Period	t _{HV}	-	960	-	tclk	
	Blank	t _{HB}	72	140	320	tclk	
	Total	t _{HP}	1060	1100	1280	tclk	2200/2
Vertical	Display Period	t _{VV}	-	1080	-	Lines	
	Blank	t _{VB}	228	270	300	Lines	
	Total	t _{VP}	1308	1350	1380	Lines	
ITEM		Symbol	Min	Typ	Max	Unit	Note
Frequency	DCLK	f _{CLK}	70.5	74.25	78	MHz	148.5/2
	Horizontal	f _H	64.1	67.5	70.9	KHz	
	Vertical	f _V	47	50	53	Hz	

Note : The Input of HSYNC & VSYNC signal does not have an effect on normal operation(DE Only Mode).
The performance of the electro-optical characteristics may be influenced by variance of the vertical refresh rate.

Product Specification

3-4. Signal Timing Waveforms

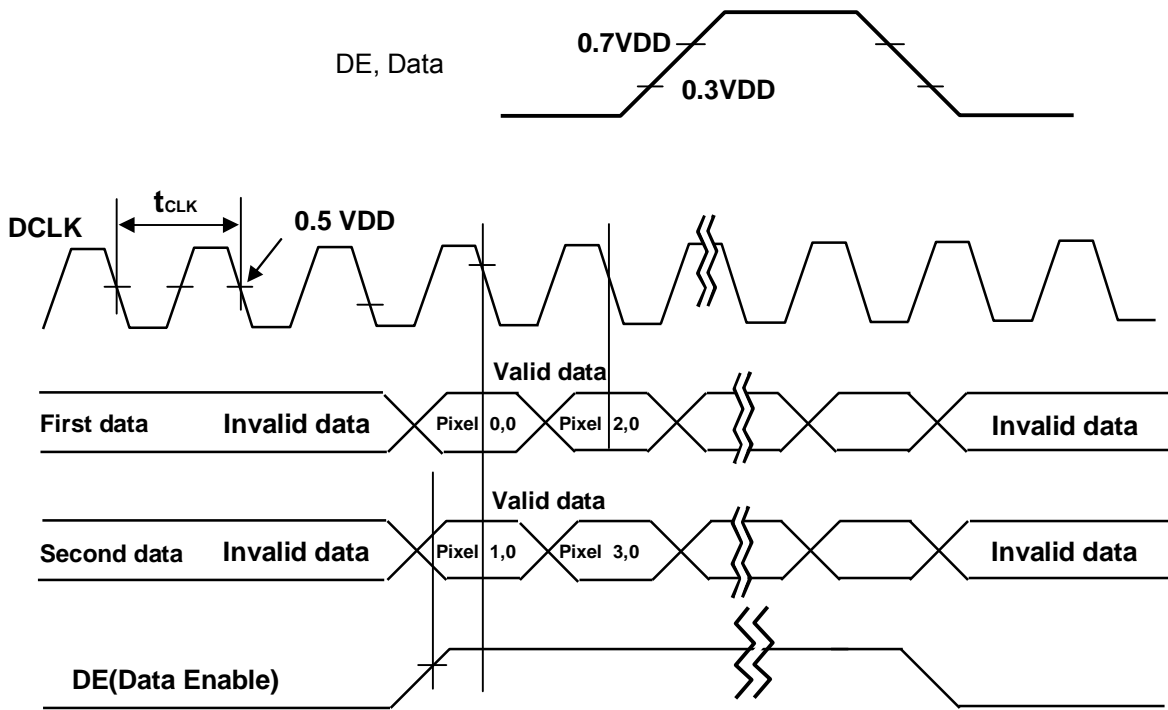

* Reference : Sync. Relation

* $t_{HB} = t_{HFP} + t_{WH} + t_{HBP}$

* $t_{VB} = t_{VFP} + t_{VW} + t_{VBP}$

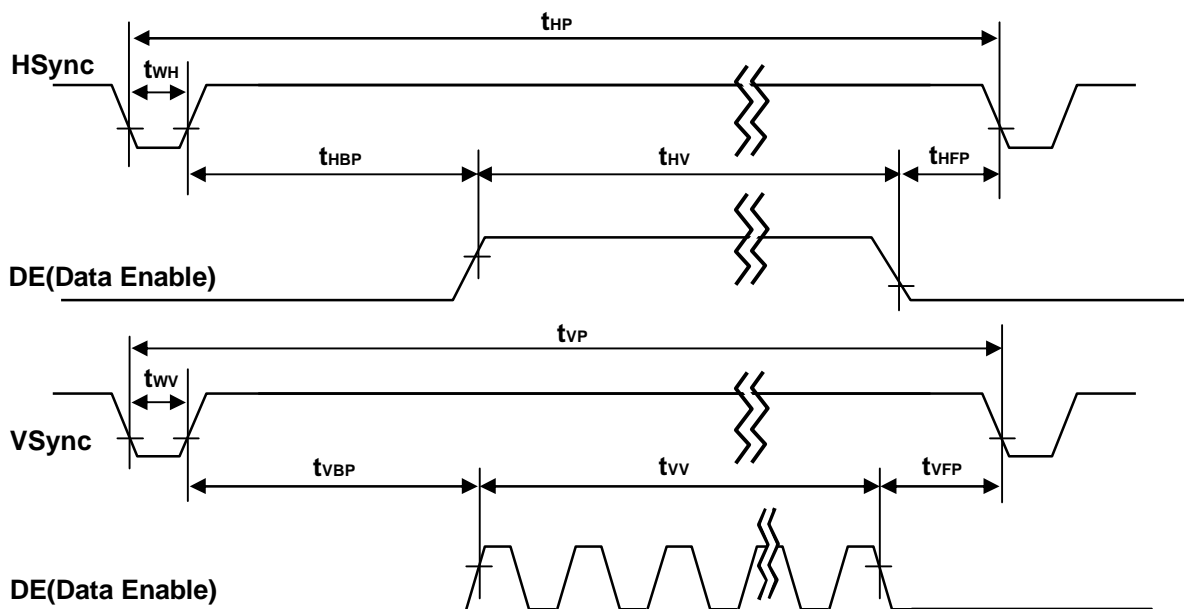

Product Specification

3-5. Color Data Reference

The brightness of each primary color(red,green,blue) is based on the 10-bit gray scale data input for the color. The higher binary input, the brighter the color. Table 8 provides a reference for color versus data input.

Table 8. COLOR DATA REFERENCE

Color		Input Color Data																													
		RED										GREEN										BLUE									
		MSB					LSB					MSB					LSB					MSB					LSB				
		R9	R8	R7	R6	R5	R4	R3	R2	R1	R0	G9	G8	G7	G6	G5	G4	G3	G2	G1	G0	B9	B8	B7	B6	B5	B4	B3	B2	B1	B0
Basic Color	Black	0	0	0	0	0	0	0	0	0	0	0	0	0	0	0	0	0	0	0	0	0	0	0	0	0	0	0	0	0	0
	Red (1023)	1	1	1	1	1	1	1	1	1	1	0	0	0	0	0	0	0	0	0	0	0	0	0	0	0	0	0	0	0	0
	Green (1023)	0	0	0	0	0	0	0	0	0	0	1	1	1	1	1	1	1	1	1	1	0	0	0	0	0	0	0	0	0	0
	Blue (1023)	0	0	0	0	0	0	0	0	0	0	0	0	0	0	0	0	0	0	0	0	1	1	1	1	1	1	1	1	1	1
	Cyan	0	0	0	0	0	0	0	0	0	0	1	1	1	1	1	1	1	1	1	1	1	1	1	1	1	1	1	1	1	1
	Magenta	1	1	1	1	1	1	1	1	1	1	0	0	0	0	0	0	0	0	0	0	1	1	1	1	1	1	1	1	1	1
	Yellow	1	1	1	1	1	1	1	1	1	1	1	1	1	1	1	1	1	1	1	1	0	0	0	0	0	0	0	0	0	0
	White	1	1	1	1	1	1	1	1	1	1	1	1	1	1	1	1	1	1	1	1	1	1	1	1	1	1	1	1	1	1
RED	RED (000)	0	0	0	0	0	0	0	0	0	0	0	0	0	0	0	0	0	0	0	0	0	0	0	0	0	0	0	0	0	
	RED (001)	0	0	0	0	0	0	0	0	0	0	0	0	0	0	0	0	0	0	0	0	0	0	0	0	0	0	0	0	0	
		
	RED (1022)	1	1	1	1	1	1	1	1	1	0	0	0	0	0	0	0	0	0	0	0	0	0	0	0	0	0	0	0	0	
	RED (1023)	1	1	1	1	1	1	1	1	1	0	0	0	0	0	0	0	0	0	0	0	0	0	0	0	0	0	0	0	0	
GREEN	GREEN (000)	0	0	0	0	0	0	0	0	0	0	0	0	0	0	0	0	0	0	0	0	0	0	0	0	0	0	0	0	0	
	GREEN (001)	0	0	0	0	0	0	0	0	0	0	0	0	0	0	0	0	0	0	0	0	0	0	0	0	0	0	0	0	0	
			
	GREEN (1022)	0	0	0	0	0	0	0	0	0	1	1	1	1	1	1	1	1	1	1	0	0	0	0	0	0	0	0	0	0	
	GREEN (1023)	0	0	0	0	0	0	0	0	0	1	1	1	1	1	1	1	1	1	1	0	0	0	0	0	0	0	0	0	0	
BLUE	BLUE (000)	0	0	0	0	0	0	0	0	0	0	0	0	0	0	0	0	0	0	0	0	0	0	0	0	0	0	0	0	0	
	BLUE (001)	0	0	0	0	0	0	0	0	0	0	0	0	0	0	0	0	0	0	0	0	0	0	0	0	0	0	0	0	1	
			
	BLUE (1022)	0	0	0	0	0	0	0	0	0	0	0	0	0	0	0	0	0	0	0	1	1	1	1	1	1	1	1	1	0	
	BLUE (1023)	0	0	0	0	0	0	0	0	0	0	0	0	0	0	0	0	0	0	0	1	1	1	1	1	1	1	1	1	1	

3-6. Power Sequence

3-6-1. LCD Driving circuit

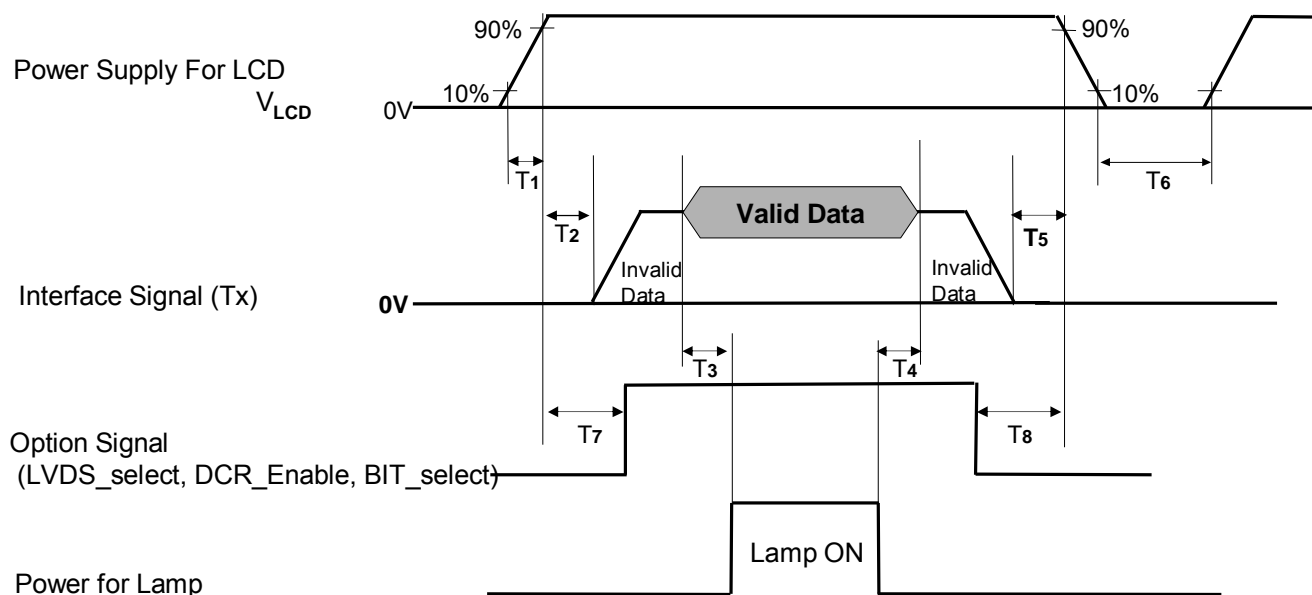

Table 9. POWER SEQUENCE

Parameter	Value			Unit	Notes
	Min	Typ	Max		
T1	0.5	-	20	ms	
T2	0	-	-	ms	4
T3	200	-	-	ms	3
T4	200	-	-	ms	3
T5	0	-	-	ms	
T6	2.0	-	-	s	5
T7	0	-	T2	ms	4
T8	0	-	-	ms	4

- Note :
1. Please avoid floating state of interface signal at invalid period.
 2. When the interface signal is invalid, be sure to pull down the power supply V_{LCD} to 0V.
 3. The T3/T4 is recommended value, the case when failed to meet a minimum specification, abnormal display would be shown. There is no reliability problem.
 4. If the on time of signals (Interface signal and Option signals) precedes the on time of Power (V_{LCD}), check the LCD logic Power (V_{CC}) is under 0.8V, otherwise it will be happened abnormal display.
 5. T6 should be measured after the Module has been fully discharged between power off and on period.

Product Specification

3-6-2. Sequence for Inverter

Power Supply For Inverter

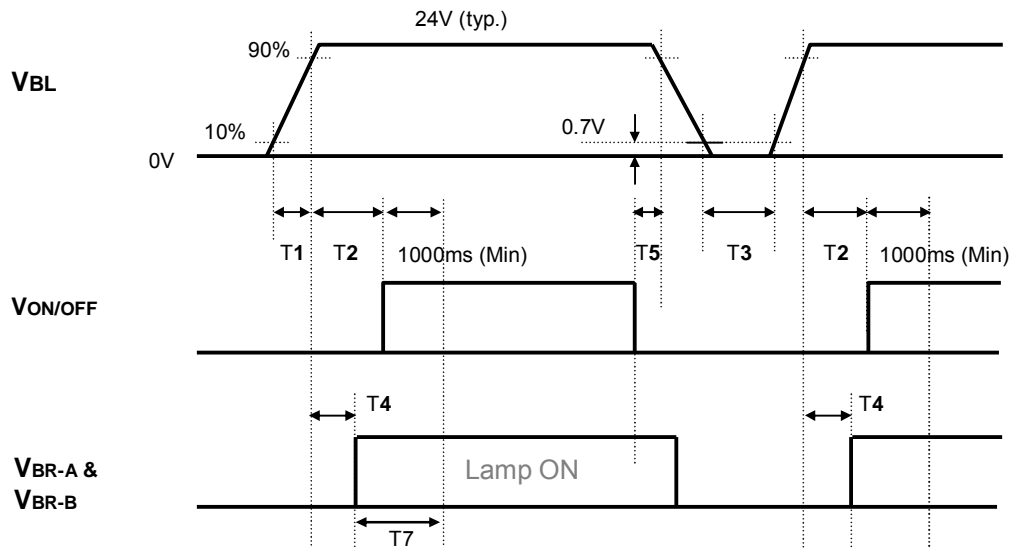

3-6-3. Deep condition for Inverter

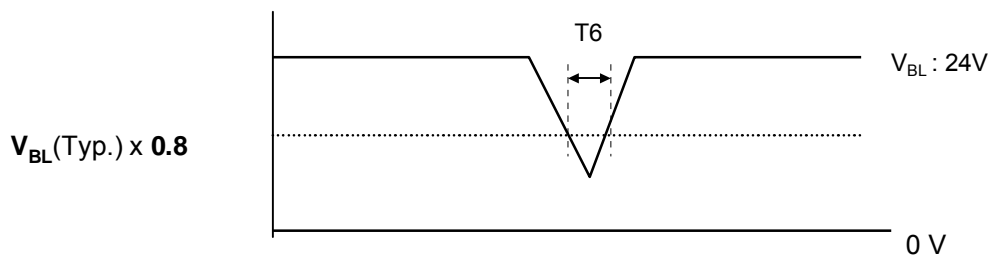

Table 10. Power Sequence for Inverter

Parameter	Values			Units	Remarks
	Min	Typ	Max		
T1	20	-	-	ms	1
T2	500	-	-	ms	
T3	200	-	-	ms	
T4	0	-	-	ms	2
T5	10	-	-	ms	
T6	-	-	10	ms	$V_{BL}(Typ) \times 0.8$
T7	1000	-	-	ms	3

- Notes :
1. T1 describes rising time of 0V to 24V and this parameter does not applied at restarting time.
 2. T4(max) is less than T2.
 3. In T7 section, V_{BR-B} is recommended 3.3V & $V_{BR-A} = 1.65V$.

Product Specification

4. Optical Specification

Optical characteristics are determined after the unit has been 'ON' and stable in a dark environment at $25 \pm 2^\circ\text{C}$. The values specified are at an approximate distance 50cm from the LCD surface at a viewing angle of Φ and θ equal to 0° .

FIG. 1 shows additional information concerning the measurement equipment and method.

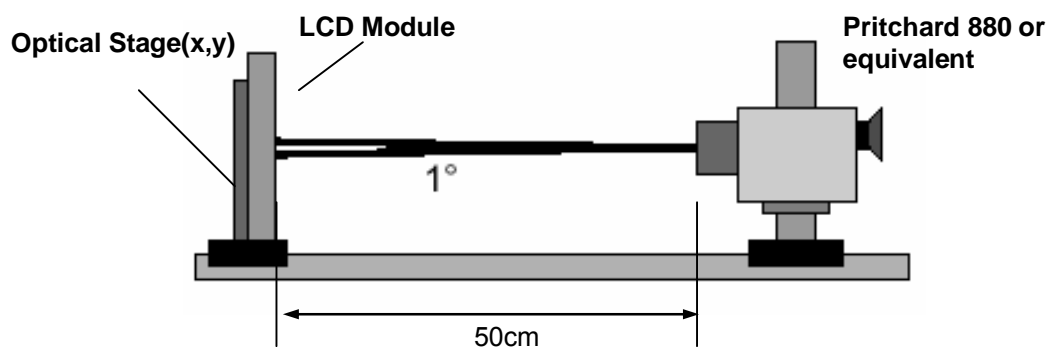

FIG. 1 Optical Characteristic Measurement Equipment and Method

$T_a = 25 \pm 2^\circ\text{C}$, $V_{\text{LCD}} = 12.0\text{V}$, $f_v = 60\text{Hz}$,
 $D_{\text{clk}} = 148.5\text{MHz}$, $V_{\text{BR-A}} = 1.65\text{V}$, $V_{\text{BR-B}} = 3.3\text{V}$

Table 11. OPTICAL CHARACTERISTICS

Parameter	Symbol	Value			Unit	Note	
		Min	Typ	Max			
Contrast Ratio	CR	900	1300	-		1	
Surface Luminance, white	L_{WH}	400	500	-	cd/m ²	2	
Luminance Variation	δ_{WHITE} 5P	-	-	1.3		3	
Response Time	Gray-to-Gray	G to G	-	5	8	ms	4
Color Coordinates [CIE1931]	RED	Rx	Typ -0.03	0.638	Typ +0.03		
		Ry		0.335			
	GREEN	Gx		0.289			
		Gy		0.609			
	BLUE	Bx		0.145			
		By		0.063			
	WHITE	Wx		0.279			
Wy	0.292						
Viewing Angle (CR>10)							
	x axis, right($\phi=0^\circ$)	θ_r	89	-	-	degree	5
	x axis, left ($\phi=180^\circ$)	θ_l	89	-	-		
	y axis, up ($\phi=90^\circ$)	θ_u	89	-	-		
	y axis, down ($\phi=270^\circ$)	θ_d	89	-	-		
Gray Scale			-	-	-		6

Product Specification

Notes :1. Contrast Ratio(CR) is defined mathematically as :

CR(Contrast Ratio) = Maximum CR_n (n=1, 2, 3, 4, 5)

$$CR_n = \frac{\text{Surface Luminance at position n with all white pixels}}{\text{Surface Luminance at position n with all black pixels}}$$

n = the Position number(1, 2, 3, 4, 5). For more information, see FIG 2.

※ DCR Application : Refer to Appendix V

2. Surface luminance are determined after the unit has been 'ON' and 30min after lighting the backlight in a dark environment at $25 \pm 2^\circ\text{C}$. Surface luminance is the luminance value at center 1-point across the LCD surface 50cm from the surface with all pixels displaying white. For more information see the FIG. 2.

3. The variation in surface luminance, δ WHITE is defined as :

$$\delta \text{ WHITE}(5P) = \text{Maximum}(L_{on1}, L_{on2}, L_{on3}, L_{on4}, L_{on5}) / \text{Minimum}(L_{on1}, L_{on2}, L_{on3}, L_{on4}, L_{on5})$$

Where L_{on1} to L_{on5} are the luminance with all pixels displaying white at 5 locations .

For more information, see the FIG. 2.

4. Response time is the time required for the display to transition from G(N) to G(M) (Rise Time, Tr_R) and from G(M) to G(N) (Decay Time, Tr_D). For additional information see the FIG. 3. (N<M)

※ G to G Spec stands for average value of all measured points.

5. Viewing angle is the angle at which the contrast ratio is greater than 10. The angles are determined for the horizontal or x axis and the vertical or y axis with respect to the z axis which is normal to the LCD module surface. For more information, see the FIG. 4.

6. Gray scale specification

Gamma Value is approximately 2.2. For more information, see the Table 12.

Table 12. GRAY SCALE SPECIFICATION

Gray Level	Luminance [%] (Typ.)
L0	0.08
L63	0.22
L127	1.03
L191	2.52
L255	4.74
L319	7.74
L383	11.56
L447	16.22
L511	21.76
L575	28.20
L639	35.56
L703	43.85
L767	53.10
L831	63.33
L895	74.54
L959	86.76
L1023	100

Product Specification

Measuring point for surface luminance & measuring point for luminance variation.

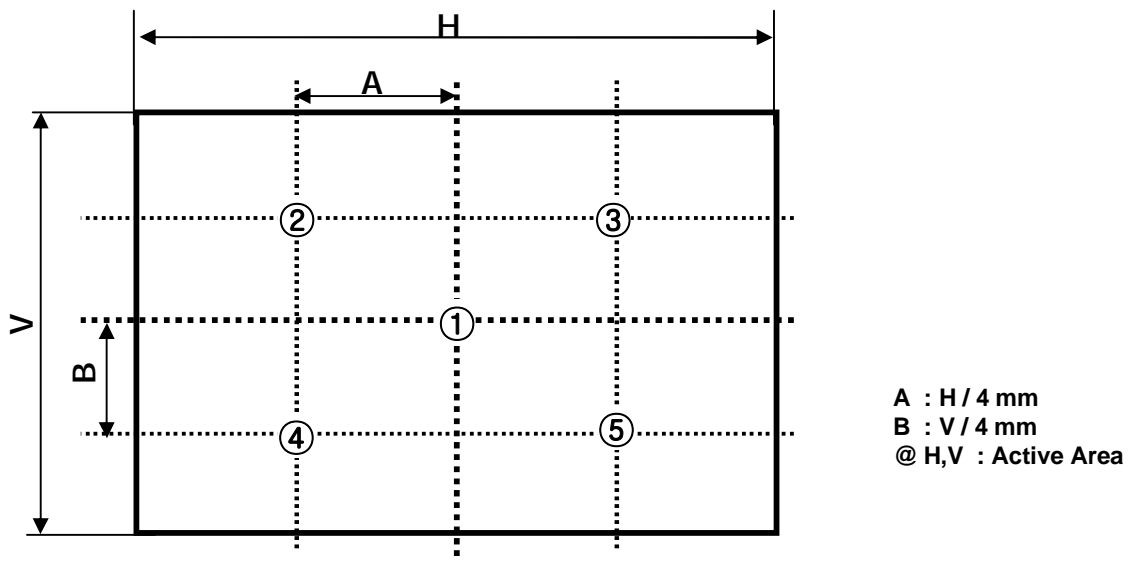

FIG. 2 5 Points for Luminance Measure

Response time is defined as the following figure and shall be measured by switching the input signal for "Gray(N)" and "Gray(M)".

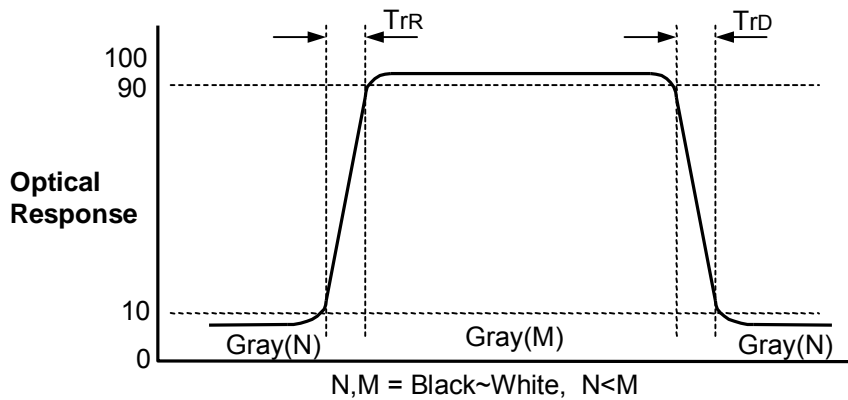

FIG. 3 Response Time

Product Specification

Dimension of viewing angle range

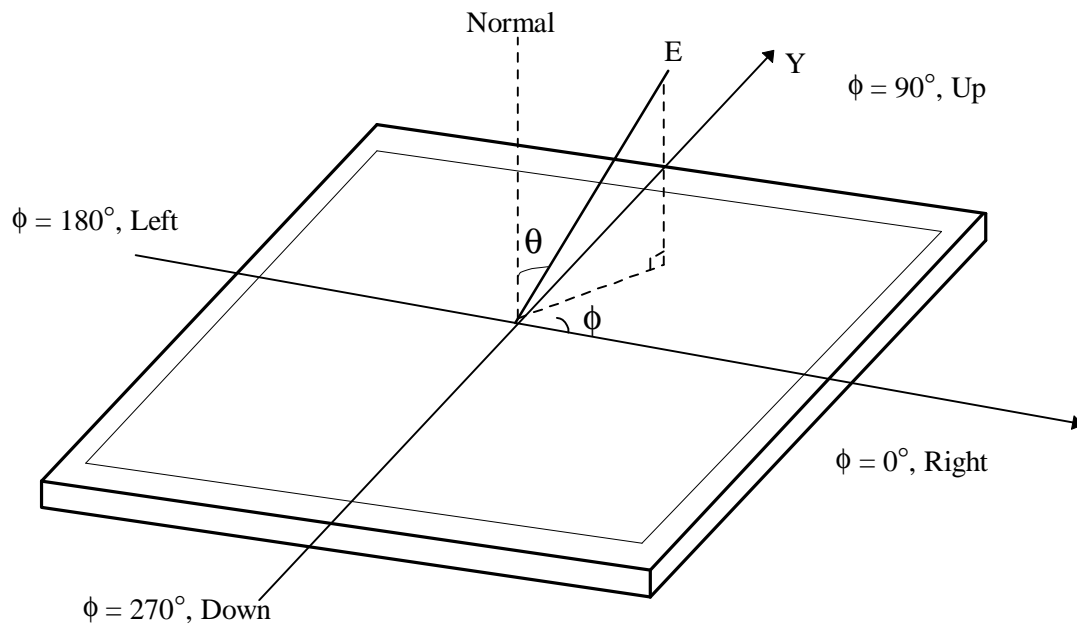

FIG. 4 Viewing Angle

Product Specification

5. Mechanical Characteristics

Table 13 provides general mechanical characteristics.

Table 13. MECHANICAL CHARACTERISTICS

Item	Value	
Outline Dimension	Horizontal	1096.0 mm
	Vertical	640.0 mm
	Depth	51.0 mm
Bezel Area	Horizontal	1049.0 mm
	Vertical	593.0 mm
Active Display Area	Horizontal	1039.68 mm
	Vertical	584.82 mm
Weight	14.5 Kg (Typ.), 15.5 Kg (Max.)	

Note : Please refer to a mechanic drawing in terms of tolerance at the next page.

Product Specification

<FRONT VIEW>

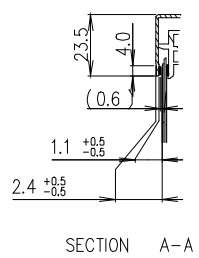
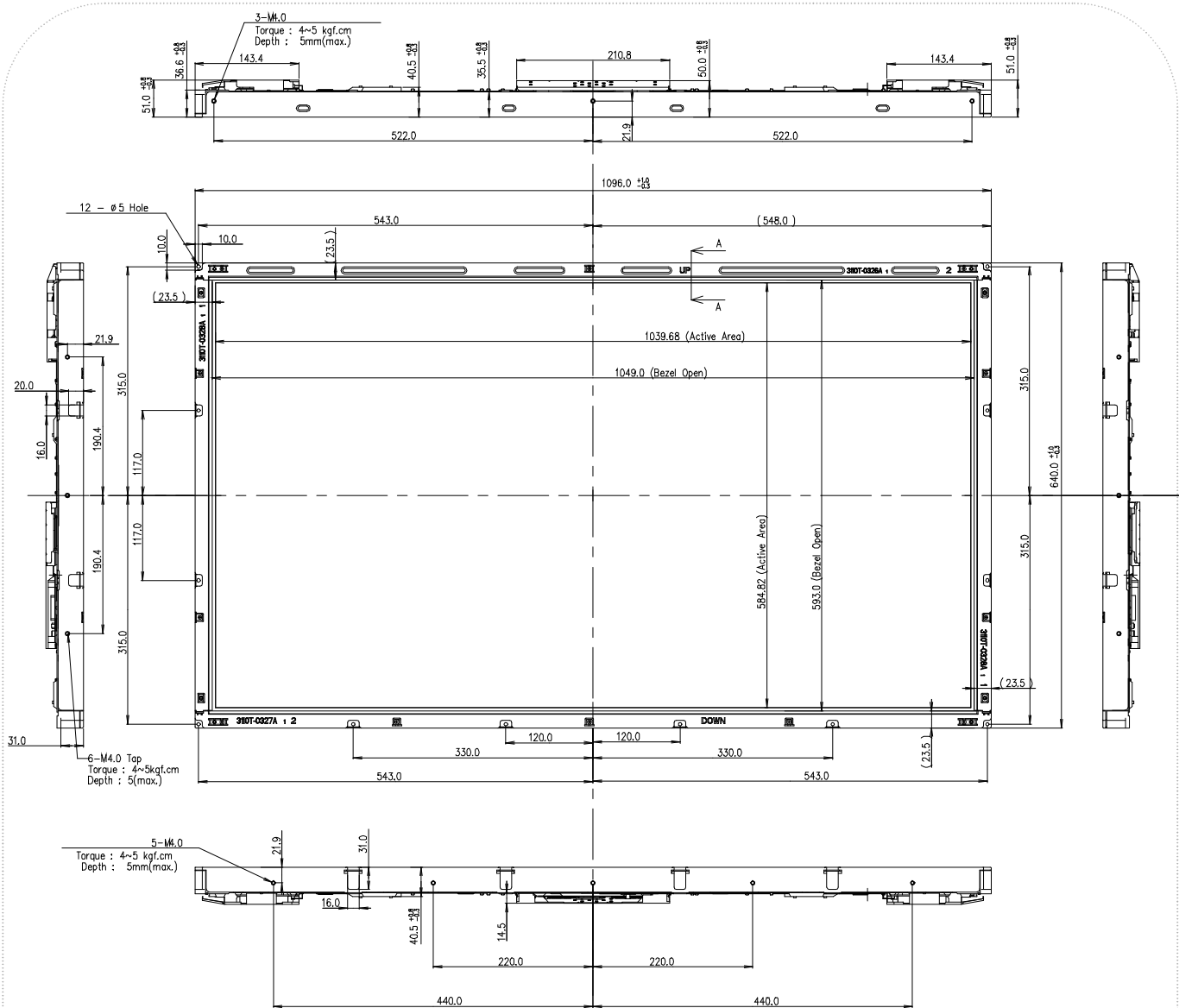

NOTES
 1. Unspecified tolerances are to be ± 1.0 mm.
 2. Tilt and partial disposition tolerance of display area are as following.
 (1) X-Direction : IA-BI ≤ 1.5 mm
 (2) Y-Direction : IC-DI ≤ 1.5 mm

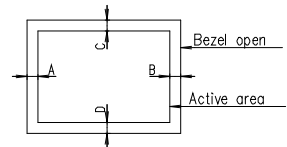

Product Specification

<REAR VIEW>

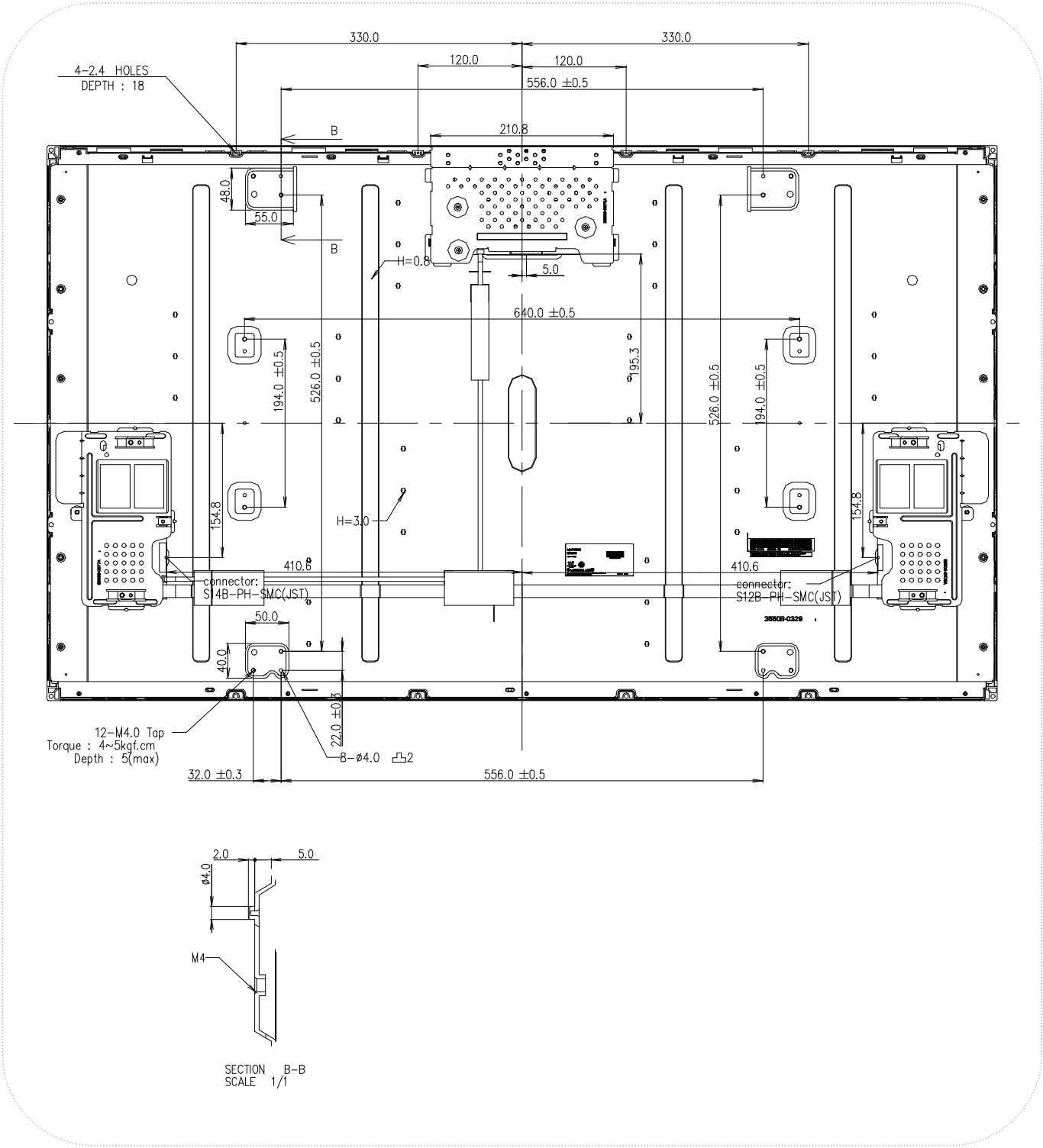

Product Specification

6. Reliability**Table 14. ENVIRONMENT TEST CONDITION**

No.	Test Item	Condition
1	High temperature storage test	Ta= 60°C 240h
2	Low temperature storage test	Ta= -20°C 240h
3	High temperature operation test	Ta= 50°C 50%RH 240h
4	Low temperature operation test	Ta= 0°C 240h
5	Vibration test (non-operating)	Wave form : random Vibration level : 1.0G RMS Bandwidth : 10-300Hz Duration : X,Y,Z, 30 min One time each direction
6	Shock test (non-operating)	Shock level :50G(X,Y axis) , 35G(Z axis) Waveform : half sine wave, 11ms Direction : ±X, ±Y, ±Z One time each direction
7	Humidity condition Operation	Ta= 40 °C, 90%RH
8	Altitude operating storage / shipment	0 - 15,000 feet 0 - 40,000 feet

Note : Before and after Reliability test, LCM should be operated with normal function.

7. International Standards

7-1. Safety

- a) UL 60065, 7th Edition, dated June 30, 2003, Underwriters Laboratories, Inc., Standard for Audio, Video and Similar Electronic Apparatus.
- b) CAN/CSA C22.2, No. 60065:03, Canadian Standards Association, Standard for Audio, Video and Similar Electronic Apparatus.
- c) IEC60065:2001, 7th Edition CB-scheme and EN 60065:2002, Safety requirements for Audio, Video and Similar Electronic Apparatus..

7-2. EMC

- a) ANSI C63.4 "Methods of Measurement of Radio-Noise Emissions from Low-Voltage Electrical and Electrical Equipment in the Range of 9kHz to 40GHz. "American National Standards Institute(ANSI), 1992
- b) CISPR13 "Limits and Methods of Measurement of Radio interference characteristics of Sound and Television broadcast receivers and associated equipment"
CISPR22 "Limits and Methods of Measurement of Radio interference characteristics of Information Technology Equipment" International Special Committee on Radio Interference.
- c) EN55013 "Limits and Methods of Measurement of Radio interference characteristics of Sound and Television broadcast receivers and associated equipment"
EN55022 "Limits and Methods of Measurement of Radio interference characteristics of Information Technology Equipment" European Committee for Electro Technical Standardization.(CENELEC), 1988(Including A1:2000)

Product Specification

8. Packing**8-1. Designation of Lot Mark**

a) Lot Mark

A	B	C	D	E	F	G	H	I	J	K	L	M
---	---	---	---	---	---	---	---	---	---	---	---	---

A,B,C : SIZE(INCH)

D : YEAR

F : PANEL CODE

H : ASSEMBLY CODE

E : MONTH

G : FACTORY CODE

I,J,K,L,M : SERIAL NO.

Note

1. YEAR

Year	2001	2002	2003	2004	2005	2006	2007	2008	2009	2010
Mark	1	2	3	4	5	6	7	8	9	0

2. MONTH

Month	Jan	Feb	Mar	Apr	May	Jun	Jul	Aug	Sep	Oct	Nov	Dec
Mark	1	2	4	4	5	6	7	8	9	A	B	C

b) Location of Lot Mark

Serial NO. is printed on the label. The label is attached to the backside of the LCD module.
This is subject to change without prior notice.

8-2. Packing Form

a) Package quantity in one Pallet : 12 pcs

b) Pallet Size : 1300mm(W) X 1140mm(D) X 860mm(H)

9. Precautions

Please pay attention to the followings when you use this TFT LCD module.

9-1. Mounting Precautions

- (1) You must mount a module using specified mounting holes (Details refer to the drawings).
- (2) You should consider the mounting structure so that uneven force (ex. Twisted stress) is not applied to the module. And the case on which a module is mounted should have sufficient strength so that external force is not transmitted directly to the module.
- (3) Please attach the surface transparent protective plate to the surface in order to protect the polarizer. Transparent protective plate should have sufficient strength in order to resist external force.
- (4) You should adopt radiation structure to satisfy the temperature specification.
- (5) Acetic acid type and chlorine type materials for the cover case are not desirable because the former generates corrosive gas of attacking the polarizer at high temperature and the latter causes circuit break by electro-chemical reaction.
- (6) Do not touch, push or rub the exposed polarizers with glass, tweezers or anything harder than HB pencil lead. And please do not rub with dust clothes with chemical treatment. Do not touch the surface of polarizer for bare hand or greasy cloth. (Some cosmetics are detrimental to the polarizer.)
- (7) When the surface becomes dusty, please wipe gently with absorbent cotton or other soft materials like chamois soaks with petroleum benzine. Normal-hexane is recommended for cleaning the adhesives used to attach front / rear polarizers. Do not use acetone, toluene and alcohol because they cause chemical damage to the polarizer.
- (8) Wipe off saliva or water drops as soon as possible. Their long time contact with polarizer causes deformations and color fading.
- (9) Do not open the case because inside circuits do not have sufficient strength.

9-2. Operating Precautions

- (1) The spike noise causes the mis-operation of circuits. It should be lower than following voltage :
 $V = \pm 200\text{mV}$ (Over and under shoot voltage)
- (2) Response time depends on the temperature. (In lower temperature, it becomes longer.)
- (3) Brightness depends on the temperature. (In lower temperature, it becomes lower.)
 And in lower temperature, response time (required time that brightness is stable after turned on) becomes longer
- (4) Be careful for condensation at sudden temperature change. Condensation makes damage to polarizer or electrical contacted parts. And after fading condensation, smear or spot will occur.
- (5) When fixed patterns are displayed for a long time, remnant image is likely to occur.
- (6) Module has high frequency circuits. Sufficient suppression to the electromagnetic interference shall be done by system manufacturers. Grounding and shielding methods may be important to minimize the interference.
- (7) Please do not give any mechanical and/or acoustical impact to LCM. Otherwise, LCM can't be operated its full characteristics perfectly.
- (8) A screw which is fastened up the steels should be a machine screw.
 (if not, it can cause conductive particles and deal LCM a fatal blow)
- (9) Please do not set LCD on its edge.
- (10) It is recommended to avoid the signal cable and conductive material over the inverter transformer for it can cause the abnormal display and temperature rising.
- (11) Partial darkness may happen during 3~5 minutes when LCM is operated initially in condition that luminance is under 40% at low temperature (under 5°C). This phenomenon which disappears naturally after 3~5 minutes is not a problem about reliability but LCD characteristic

9-3. Electrostatic Discharge Control

Since a module is composed of electronic circuits, it is not strong to electrostatic discharge. Make certain that treatment persons are connected to ground through wrist band etc. And don't touch interface pin directly.

9-4. Precautions for Strong Light Exposure

Strong light exposure causes degradation of polarizer and color filter.

9-5. Storage

When storing modules as spares for a long time, the following precautions are necessary.

- (1) Store them in a dark place. Do not expose the module to sunlight or fluorescent light. Keep the temperature between 5°C and 35°C at normal humidity.
- (2) The polarizer surface should not come in contact with any other object.
It is recommended that they be stored in the container in which they were shipped.

9-6. Handling Precautions for Protection Film

- (1) The protection film is attached to the bezel with a small masking tape.
When the protection film is peeled off, static electricity is generated between the film and polarizer.
This should be peeled off slowly and carefully by people who are electrically grounded and with well ion-blown equipment or in such a condition, etc.
- (2) When the module with protection film attached is stored for a long time, sometimes there remains a very small amount of glue still on the bezel after the protection film is peeled off.
- (3) You can remove the glue easily. When the glue remains on the bezel surface or its vestige is recognized, please wipe them off with absorbent cotton waste or other soft material like chamois soaked with normal-hexane.

APPENDIX-I-1

■ Required signal assignment for Flat Link (Thine : THC63LVD103) Transmitter(Pin7="L")

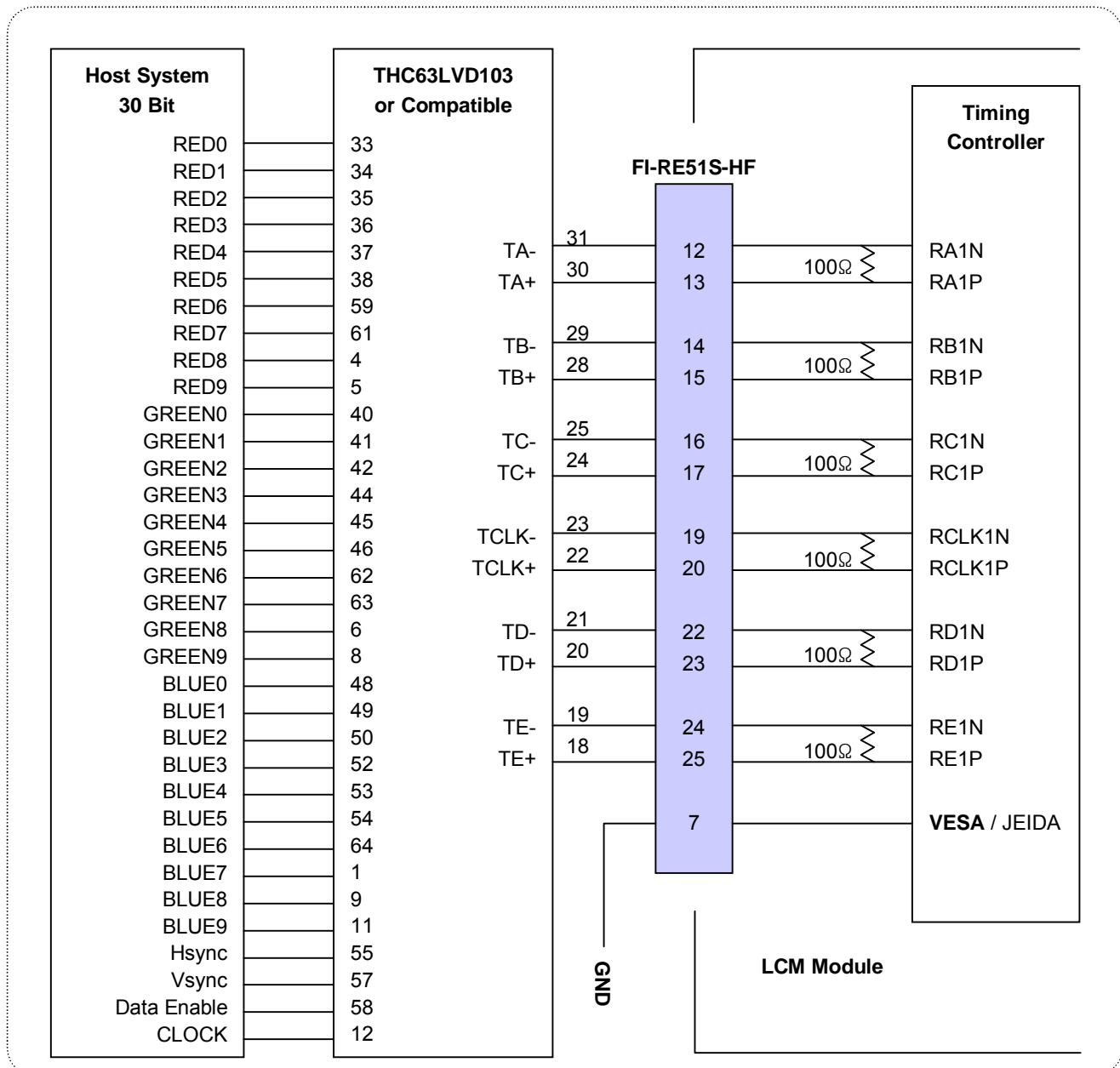

Notes:

1. The LCD module uses a 100 Ohm(Ω) resistor between positive and negative lines of each receiver input.
2. Refer to LVDS transmitter data sheet for detail descriptions. (THC63LVD103 or Compatible)
3. '9' means MSB and '0' means LSB at R,G,B pixel data.

APPENDIX-I-2

■ Required signal assignment for Flat Link (Thine : THC63LVD103) Transmitter(Pin7="H")

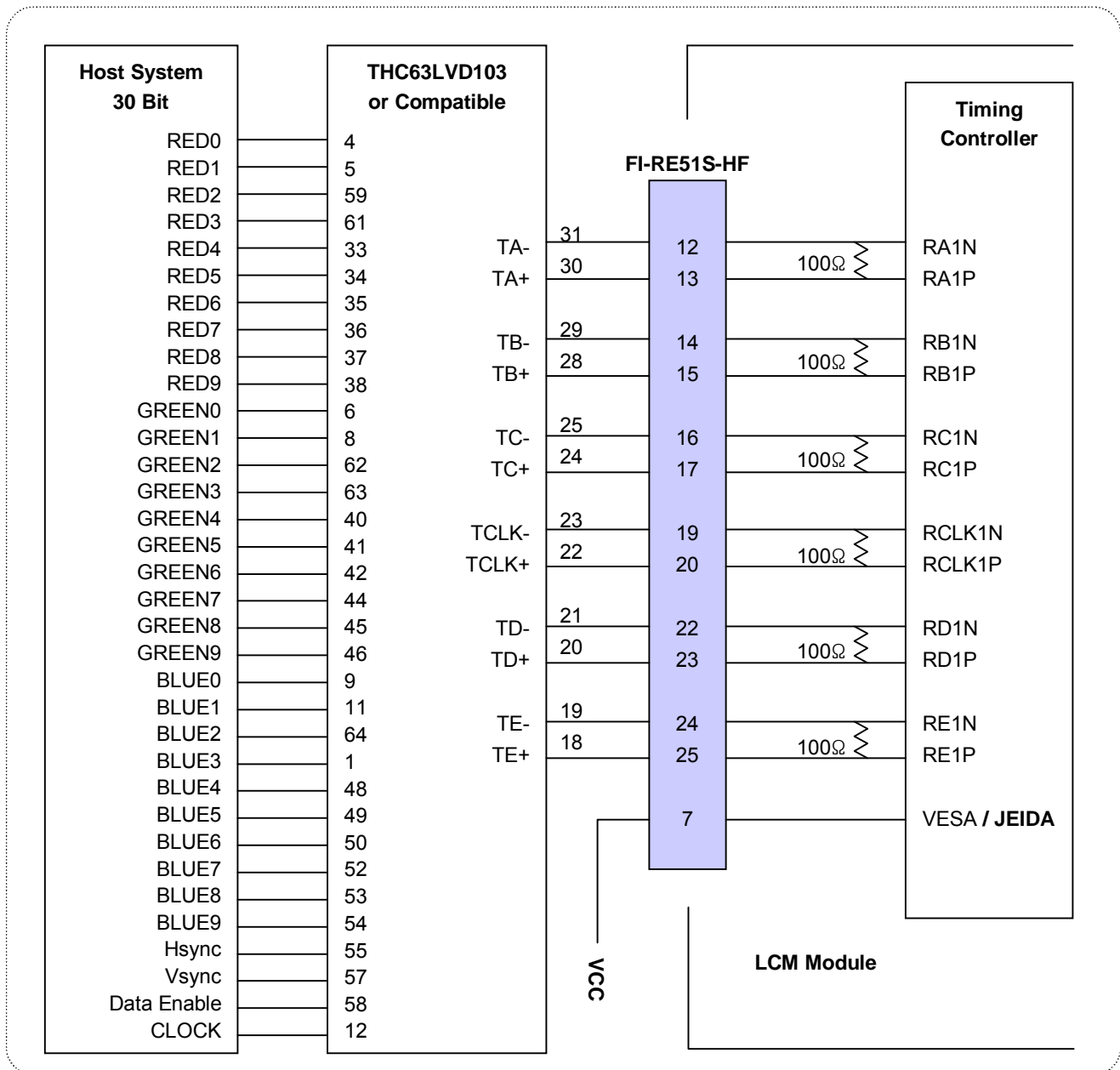

Notes:

1. The LCD module uses a 100 Ohm(Ω) resistor between positive and negative lines of each receiver input.
2. Refer to LVDS transmitter data sheet for detail descriptions. (THC63LVD103 or Compatible)
3. '9' means MSB and '0' means LSB at R,G,B pixel data.

Product Specification

APPENDIX-II

■ Pallet Ass'y

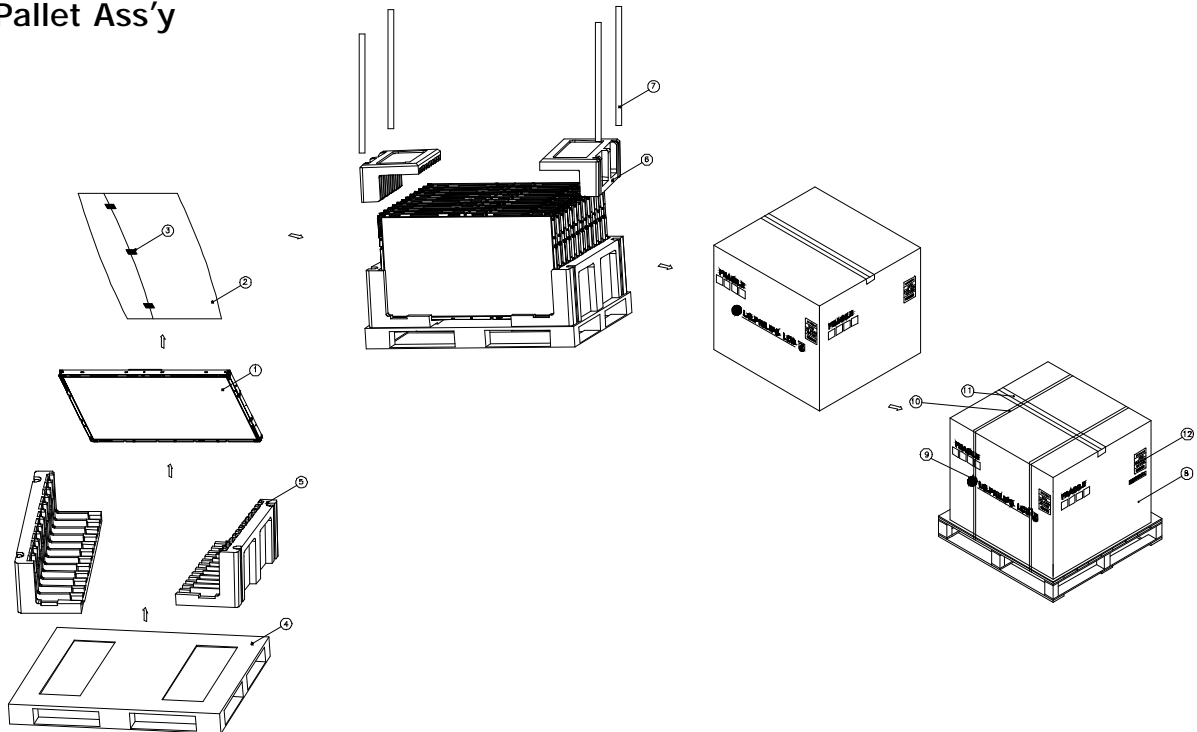

NO.	DESCRIPTION	MATERIAL
1	LCD Module	
2	BAG	47INCH
3	TAPE	MASKING 20MMX50M
4	PALLET	PAPER 1300X1140X130MM
5	PACKING,BOTTOM	EPS
6	PACKING, TOP	EPS
7	ANGLE,POST	PAPER
8	ANGLE,PACKING	PAPER
9	BAND,CLIP	STEEL
10	BAND	PP
11	TAPE	OPP
12	LABEL	YUPO 80G 100X100

Product Specification

APPENDIX- III

■ LCM Label

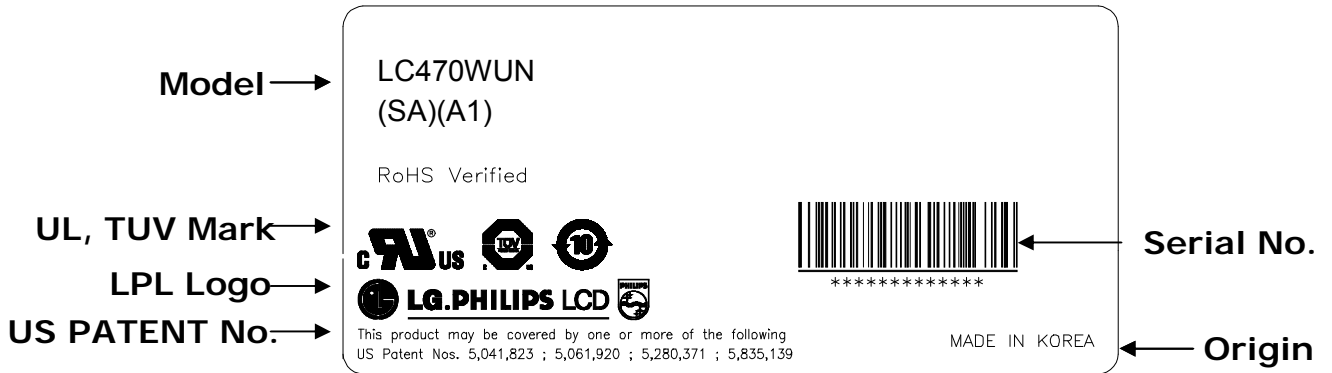

■ Serial No. (See CAS 24page for more information)

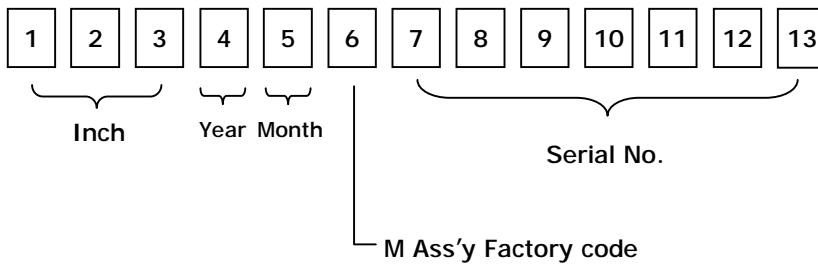

APPENDIX- IV

■ Pallet Label

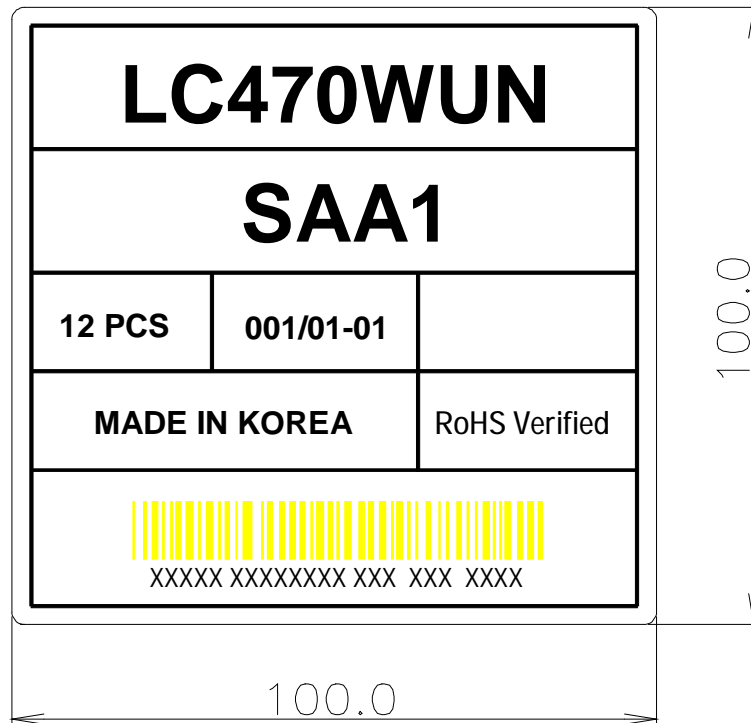

Product Specification

APPENDIX- V -1

■ LCM DCR Only (Reference)

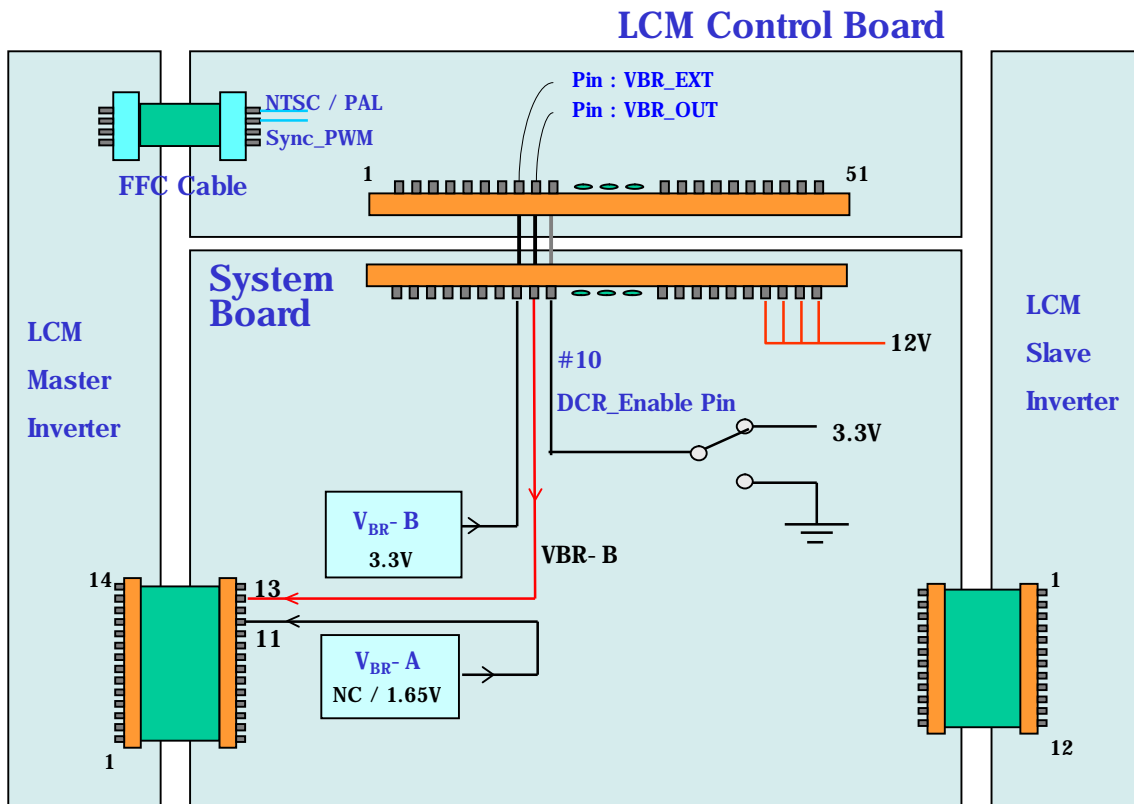

■ DCR_Enable Option Pin Description

DCR_Enable	On(3.3V)	Off (0V)
VBR_OUT (V _{BR-B}) Signal Source	From T-Con (ASIC)	From System (VBR_EXT Pin)
V _{BR-B}	0V ~ 3.3V	3.3V
V _{BR-A}	1.65V or NC	1.65V or NC
DCR Level	2600 : 1	1300 : 1

Gray Level	Luminance [%] DCR On VBR-A = 1.65V
L0	0.03
L63	0.09
L127	0.47
L191	1.51
L255	3.13
L319	5.46
L383	8.61
L447	12.7
L511	17.7
L575	23.7
L639	30.9
L703	39.2
L767	48.7
L831	59.5
L895	71.6
L959	85.1
L1023	100

APPENDIX- V -2

■ System DCR (Dynamic Contrast Ratio)- Max 13000:1 (Reference)

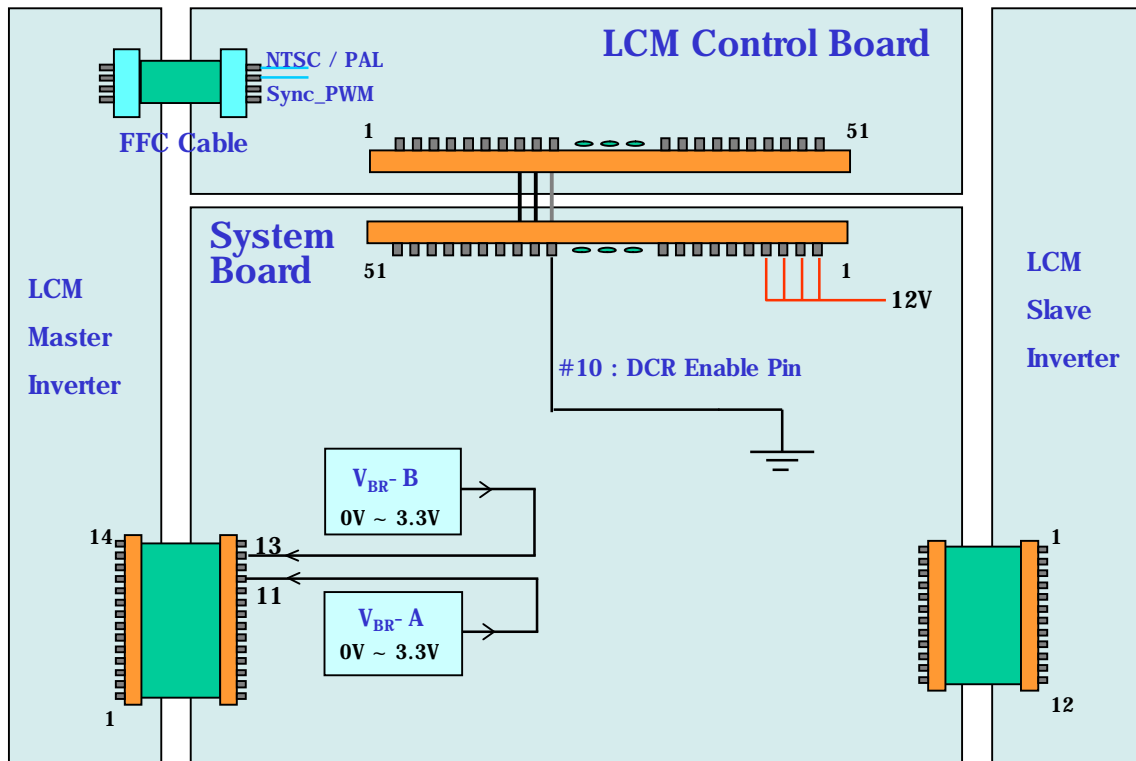

V_{BR-B}	0V ~ 3.3V	3.3V	$V_{BR-A,B}$ Voltage	Function
V_{BR-A}	0V ~ 1.65V	1.65V	$V_{BR-B} : 3.3V$ $V_{BR-A} : 1.65V$	Maximum Brightness (100%) (DCR Condition)
DCR Level	13000 : 1	1300 : 1	0V	Minimum Brightness (10%)

Note : 1. To make DCR Max 13000:1, V_{BR-A} and V_{BR-B} must be given by system.

2. DCR Max 13000:1 is defined mathematically as :

DCR = Maximum DCR_n (n=1, 2, 3, 4, 5)

$$DCR_n = \frac{\text{Surface Luminance at position n with all white pixels } (V_{BR-B}=3.3V, V_{BR-A}=1.65V)}{\text{Surface Luminance at position n with all black pixels } (V_{BR-B}=0V, V_{BR-A}=0V)}$$

n = the Position number(1, 2, 3, 4, 5). For more information, see FIG 2.

3. Measurement Sequence (aging time 10 min each pattern) :

- ① Turn On LCM
- ② Measure Black Luminance ($V_{BR-B}=0V$, $V_{BR-A}=0V$)
- ③ Measure White Luminance ($V_{BR-B}=3.3V$, $V_{BR-A}=3.3V$)

4. In case the lowest minimum brightness is continued,
it can affect the lamp reliability and appear the partial darkness.

APPENDIX- VI

Option Pin Circuit Block Diagram

Circuit Block Diagram of LVDS Format Selection pin

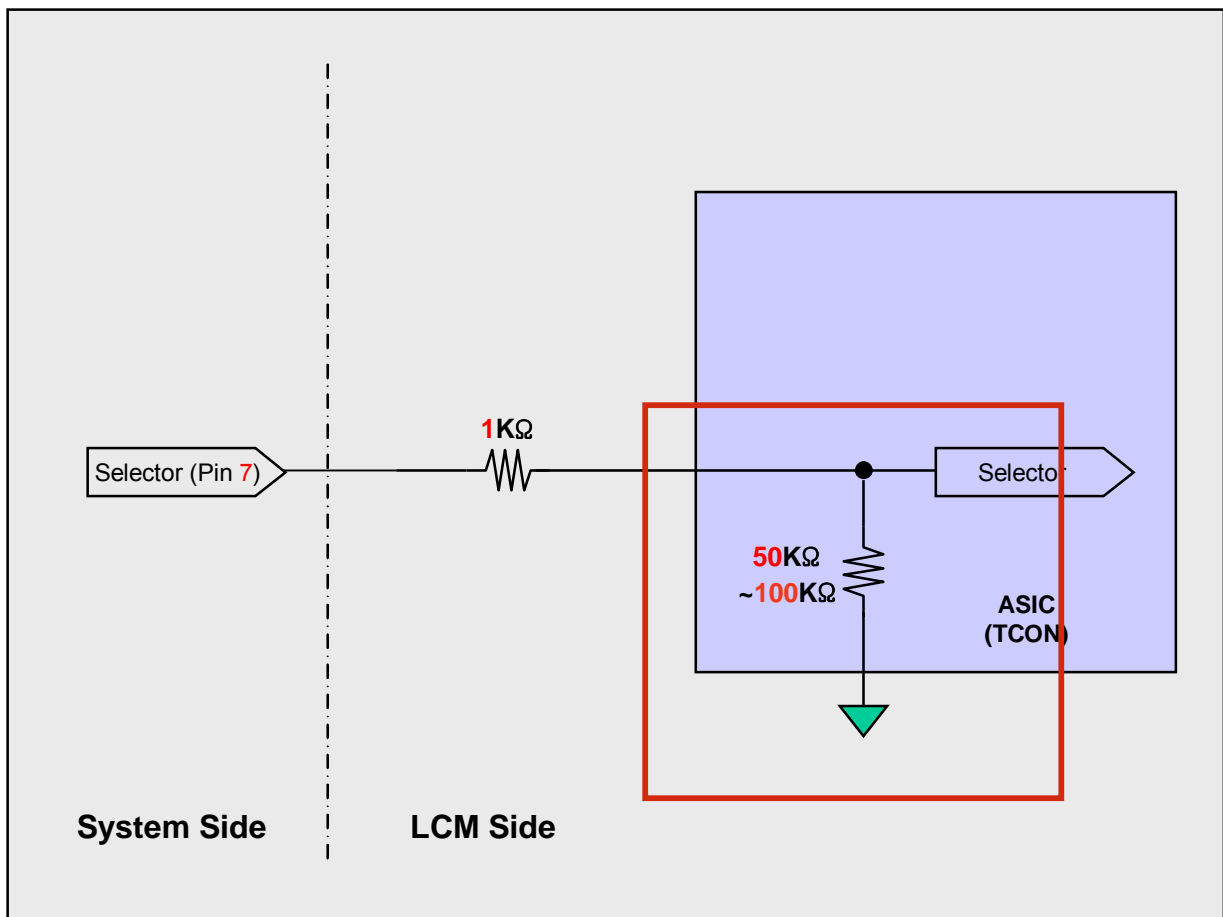

Product Specification

APPENDIX- VII

LVDS Input characteristics

1. DC Specification

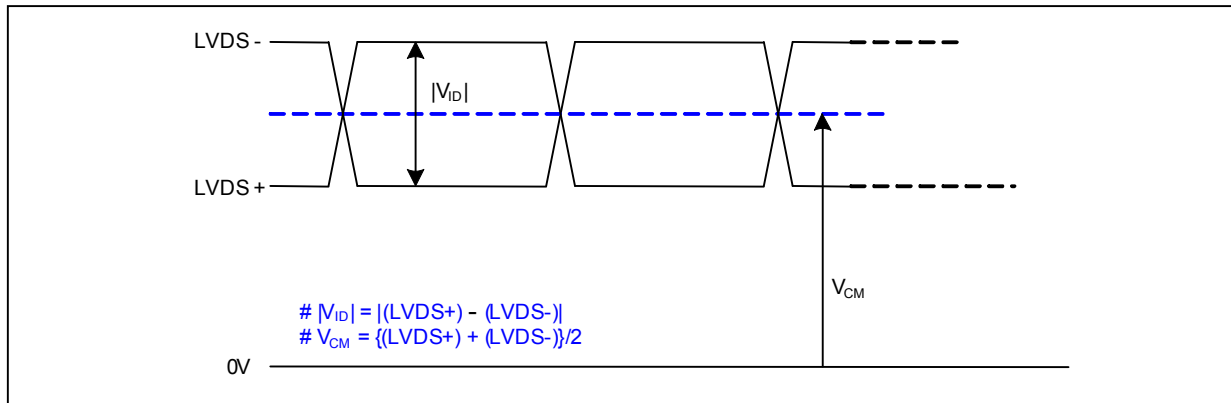

Description	Symbol	Min	Max	Unit	Notes
LVDS Differential Voltage	$ V_{ID} $	200	500	mV	-
LVDS Common mode Voltage	V_{CM}	1.0	1.5	V	-

2. AC Specification

1) LVDS Clock to data timing

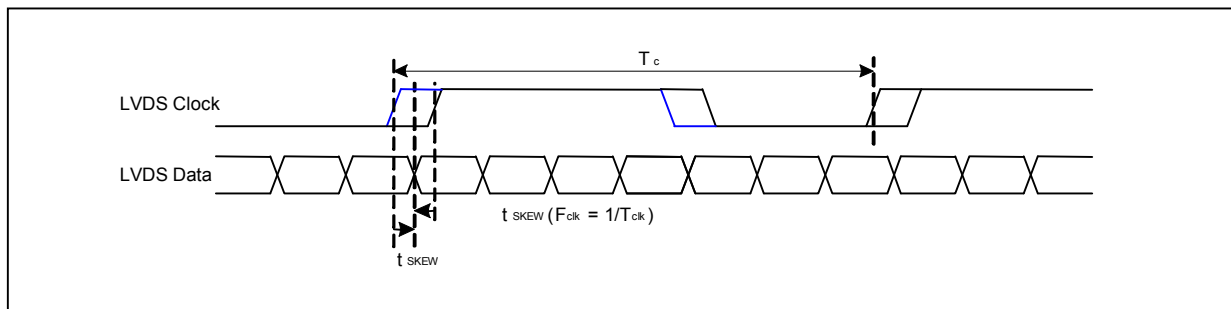

Description	Symbol	Min	Max	Unit	Notes
LVDS Clock to Data Skew Margin	t_{SKEW}	$-(T_c / 7) * 0.25$	$+(T_c / 7) * 0.25$	ps	Note 1

Product Specification

2) LVDS Clock timing

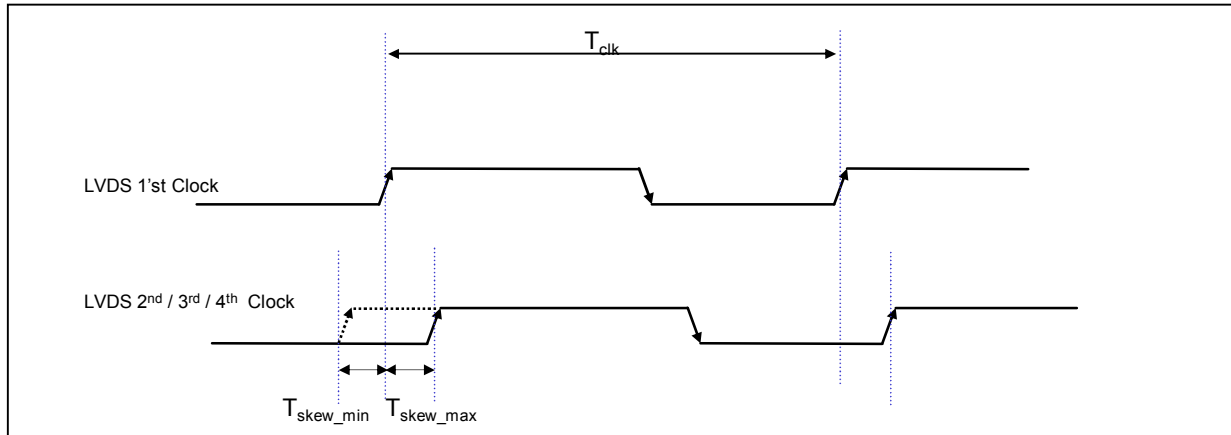

< LVDS inter-port Clock timing >

Description	Symbol	Min	Max	Unit	Notes
LVDS inter-port Clock Skew	T_{skew}	-2.0	2.5	ns	-

APPENDIX- VIII

LVDS Data-Mapping info. (10bit)

■ LVDS Select : “H” Data-Mapping (JEIDA format)

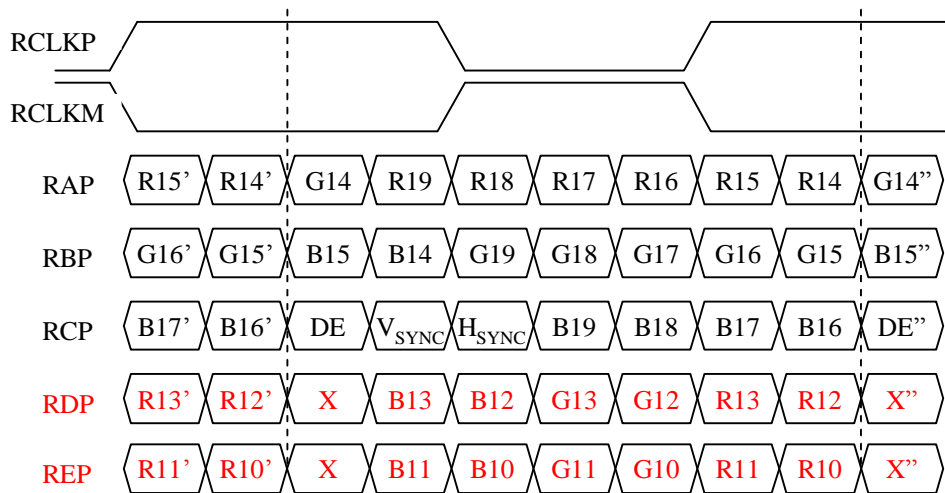

■ LVDS Select : “L” Data-Mapping (VESA format)

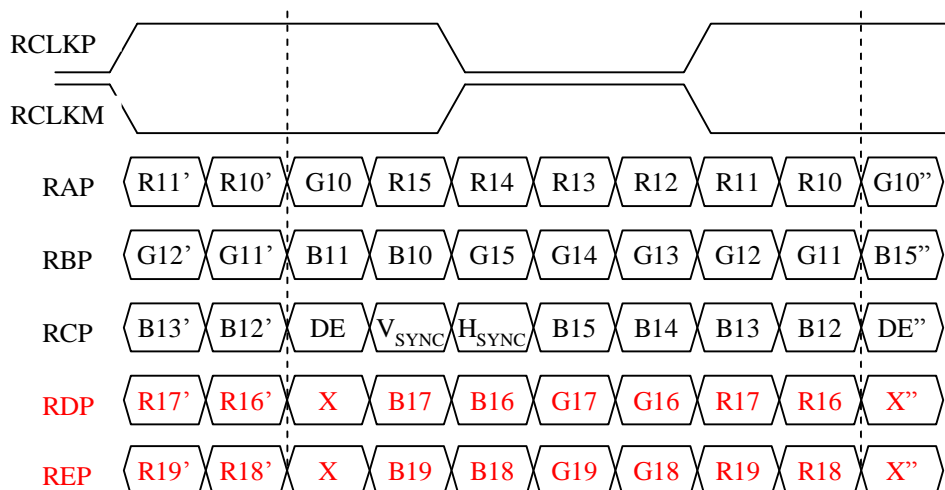

Product Specification

APPENDIX- IX

Gray to Gray Response Time Uniformity

This is only the reference data of G to G and uniformity for LC470WUN-SAA1 model.

1. G to G Response Time :
 Response time is defined as Figure3 and shall be measured by switching the input signal for "Gray (N) " and "Gray(M)".(128 Gray Step at 10bit (D))

2. G to G Uniformity
 The variation of G to G Uniformity , $\delta_{G\ to\ G}$ is defined as :

$$G\ to\ G\ Uniformity = \frac{Maximum(GtoG) - Typical(GtoG)}{Typical(GtoG)} \leq 1$$

*Maximum (GtoG) means maximum value of measured time (N, M = 0 (Black) ~ 1023(White), 128 gray step).

	0Gray	127ray	255Gray	...	895Gray	1023Gray
0Gray		TrR:0Gà 127G	TrR:0Gà 255G	...	TrR:0Gà 895G	TrR:0Gà 1023G
127Gray	TrD:127Gà 0G		TrR:127Gà 255G	...	TrR:127Gà 895G	TrR:127Gà 1023G
255Gray	TrD:255Gà 0G	TrD:255Gà 127G		...	TrR:255Gà 895G	TrR:255Gà 1023G
...
895Gray	TrD:895Gà 0G	TrD:895Gà 127G	TrD:895Gà 255G	...		TrR:895Gà 1023G
1023Gray	TrD:1023Gà 0G	TrD:1023Gà 127G	TrD:1023Gà 255G	...	TrD:1023Gà 895G	

- 3. Sampling Size : 2 pcs
- 4. Measurement Method : Follow the same rule as optical characteristics measurement.
- 5. Current Status

Below table is actual data of production on **Nov. 08, 2007 (LPL RV Event Sample)**

	G to G Response Time [ms]		Uniformity
	Min.	Max.	
# 1	3	8	0.6
# 2	3	7	0.4

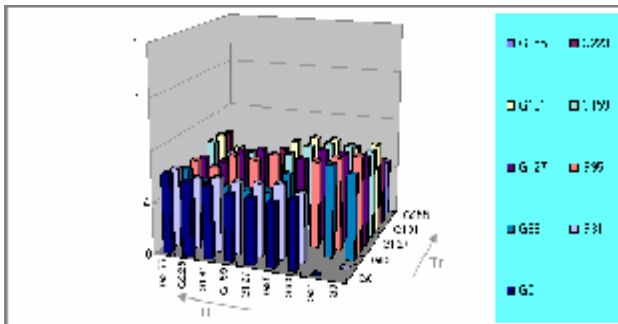

< # 1 >

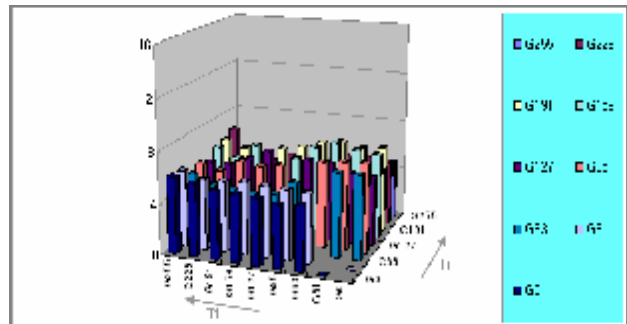

< # 2 >