

TFT-Display Datenblatt

Modell LD101WX1

Kurzdaten

Hersteller	LG Display
Diagonale	10,1" / 25,6cm
Format	16:9
Auflösung	1280x800
Backlight	LED / 400cd/m ²
Interface	LVDS
Touchscreen	nein
Temperatur	0...+50°C (Betrieb)

SPECIFICATION FOR APPROVAL

- (◆) Preliminary Specification
() Final Specification

Title	10.1" WX TFT LCD
-------	------------------

Customer	
MODEL	

SUPPLIER	LG Display Co., Ltd.
*MODEL	LD101WX1
Suffix	SL01

*When you obtain standard approval,
please use the above model name without suffix

APPROVED BY	SIGNATURE
/	_____
/	_____
/	_____

Please return 1 copy for your confirmation with your signature and comments.

APPROVED BY	SIGNATURE
_____	_____
REVIEWED BY	_____
_____	_____
PREPARED BY	_____
_____	_____

**Products Engineering Dept.
LG Display Co., Ltd**

Product Specification

Contents

No	ITEM	Page
	COVER	1
	CONTENTS	2
	RECORD OF REVISIONS	3
1	GENERAL DESCRIPTION	4
2	ABSOLUTE MAXIMUM RATINGS	5
3	ELECTRICAL SPECIFICATIONS	
3-1	ELECTRICAL CHARACTERISTICS	6
3-2	INTERFACE CONNECTION	8
3-3	LVDS SIGNAL TIMING SPECIFICATIONS	9
3-4	SIGNAL TIMING SPECIFICATIONS	11
3-5	SIGNAL TIMING WAVEFORMS	11
3-6	COLOR INPUT DATA REFERNECE	12
3-7	POWER SEQUENCE	13
4	OPTICAL SPECIFICATIONS	14
5	MECHANICAL CHARACTERISTICS	17
6	RELIABILITY	20
7	INTERNATIONAL STANDARDS	
7-1	SAFETY	21
7-2	EMC	21
8	PACKING	
8-1	DESIGNATION OF LOT MARK	22
8-2	PACKING FORM	22
9	PRECAUTIONS	23
A	APPENDIX. Enhanced Extended Display Identification Data	25

Product Specification

2. Absolute Maximum Ratings

The following are maximum values which, if exceeded, may cause faulty operation or damage to the unit.

Table 1. ABSOLUTE MAXIMUM RATINGS

Parameter	Symbol	Values		Units	Notes
		Min	Max		
Power Input Voltage	VCC	-0.3	4.0	Vdc	at 25 ± 5°C
Operating Temperature	TOP	0	50	°C	1
Storage Temperature	HST	-20	60	°C	1

Note : 1. Temperature and relative humidity range are shown in the figure below.
Wet bulb temperature should be 39°C Max, and no condensation of water.

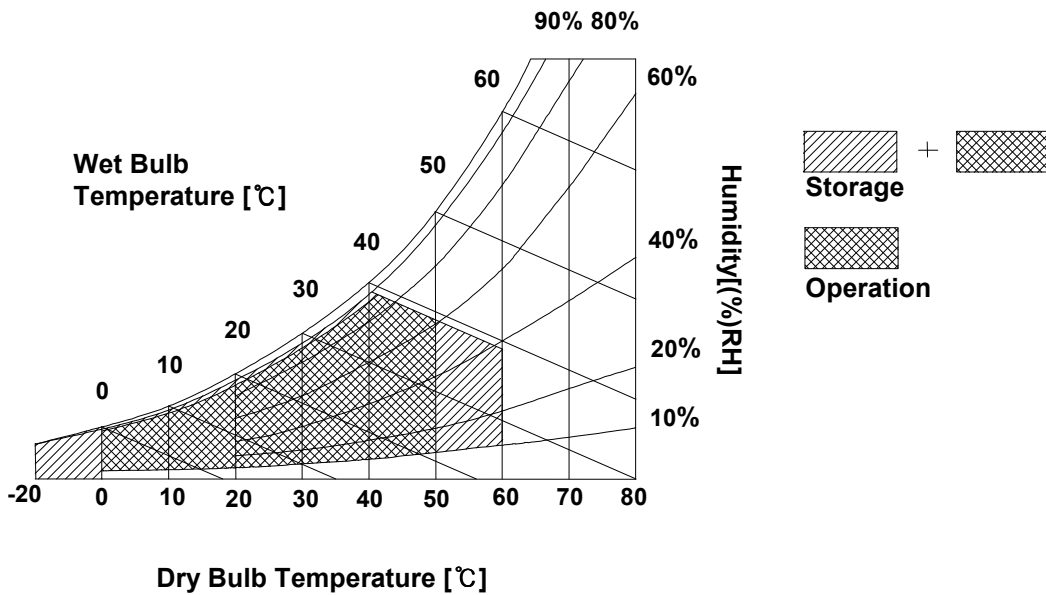

3. Electrical Specifications

3-1. Electrical Characteristics

The LD101WX1 requires two power inputs. One is employed to power the LCD electronics and to drive the TFT array and liquid crystal. The second input which powers the LED BL.

Table 2. ELECTRICAL CHARACTERISTICS

Parameter	Symbol	Values			Unit	Notes
		Min	Typ	Max		
LOGIC :						
Power Supply Input Voltage	VCC	3.0	3.3	3.6	V	1
Power Supply Input Current	Mosaic ICC	-	181	208	mA	2
Power Consumption	PCC	-	0.6	0.69	W	2
Power Supply Inrush Current	ICC_P	-		1500	mA	3
LVDS Impedance	ZLVDS	90	100	110	Ω	4
BACKLIGHT : (with LED Driver)						
LED Power Input Voltage	VLED	3			V	5
LED Power Input Current	ILED	-	843	857	mA	6
LED Power Consumption	PLED	-	2.53	2.71	W	6
LED Power Inrush Current	ILED_P	-		2000	mA	7
PWM Duty Ratio		5	-	100	%	8
PWM Jitter	-	0	-	0.2	%	9
PWM Frequency	FPWM	100	-	1000	Hz	
PWM High Level Voltage	V_{PWM_H}		1.8		V	
PWM Low Level Voltage	V_{PWM_L}	0	-	0.3	V	
LED_EN High Voltage	VLED_EN_H		1.8		V	
LED_EN Low Voltage	VLED_EN_L	0	-	0.3	V	

Product Specification

3-2. Interface Connections

This LCD employs two interface connections, a 45 pin connector used for the module electronics interface and the other connector used for the integral backlight system.

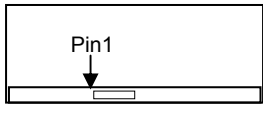
Pin	Symbol	Description	Notes
1	AVDD	LCD Logic and driver power(3.3V)	<p>[Connector] Hirose FH39J-45S-0.3SHW</p> <p>[Connector pin arrangement]</p>  <p>[LCD Module Rear View]</p> <p>[Level shift for PWM (9 pin)] - Level shift circuit for PWM can make a power consumption increased because of the switching of FET</p>
2	AVDD	LCD Logic and driver power(3.3V)	
3	AVDD	LCD Logic and driver power(3.3V)	
4	IOVDD	Power supply for level shift circuit and EDID (1.8V)	
5	NC	No connection	
6	GND	Ground	
7	GND	Ground	
8	NC	No connection	
9	LED_PWM	Back light LED driver PWM (1.8V, LGD use level shift)	
10	SDA	DDC Data (Only for EDID)	
11	SCL	DDC clock (Only for EDID)	
12	LED_EN	LED enable input level (1.8V, LGD use level shift)	
13	ID0	ID pin, Pull down 0Kohm to GND	
14	ID1	ID pin, Pull down 0Kohm to GND	
15	LVDS 0-	LVDS0 data negative signal	
16	LVDS 0+	LVDS0 data positive signal	
17	GND	Ground	
18	LVDS 1-	LVDS1 data negative signal	
19	LVDS 1+	LVDS1 data positive signal	
20	GND	Ground	
21	LVDS 2-	LVDS2 data negative signal	
22	LVDS 2+	LVDS2 data positive signal	
23	GND	Ground	
24	LVDS CLK-	LVDS Clock negative signal	
25	LVDS CLK+	LVDS Clock positive signal	
26	GND	Ground	
27	LVDS 3-	LVDS3 data negative signal	
28	LVDS 3+	LVDS3 data positive signal	
29	GND	Ground	
30	GND	Ground	
31	NC	No connection	
32	VDD-	Ground	
33	VDD-	Ground	
34	VDD-	Ground	
35	VDD-	Ground	
36	VDD-	Ground	
37	NC	No connection	
38	VDD+	Power supply for LED (3V)	
39	VDD+	Power supply for LED (3V)	
40	VDD+	Power supply for LED (3V)	
41	VDD+	Power supply for LED (3V)	
42	VDD+	Power supply for LED (3V)	
43	NC	No connection	
44	NC	No connection (LGD Only)	
45	NC	No connection (LGD Only)	

Product Specification

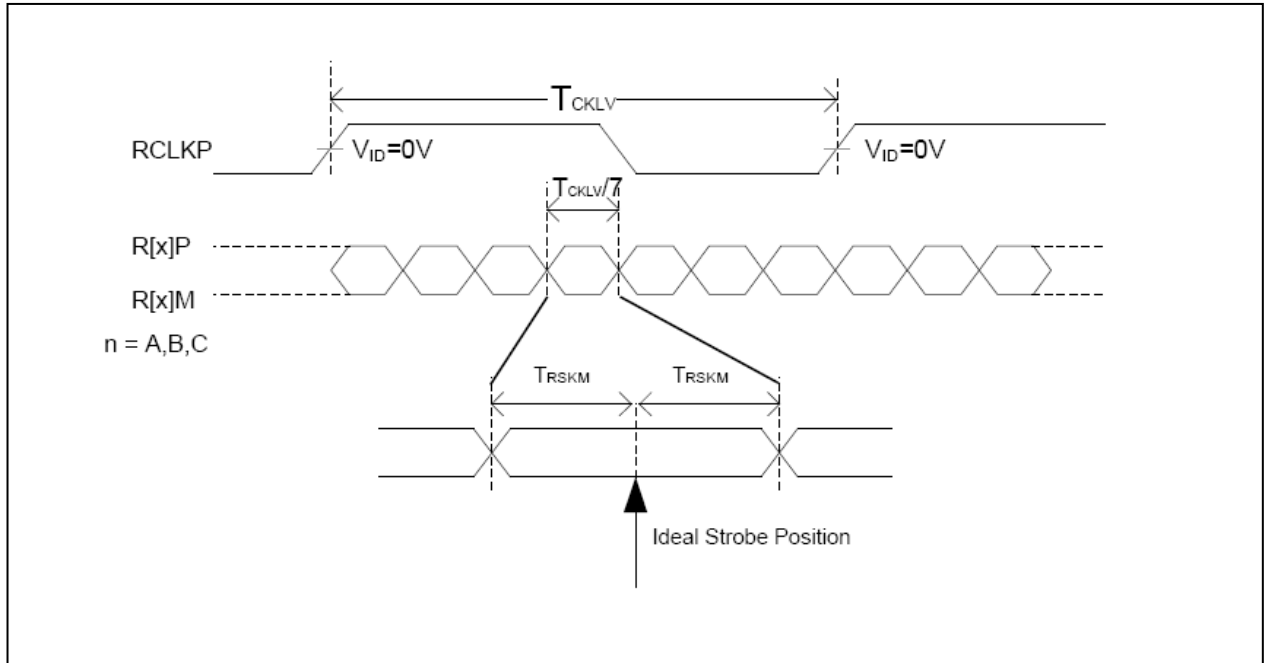

< LVDS input Skew timing >

3-3-3. Data Format

- LVDS 1 Port

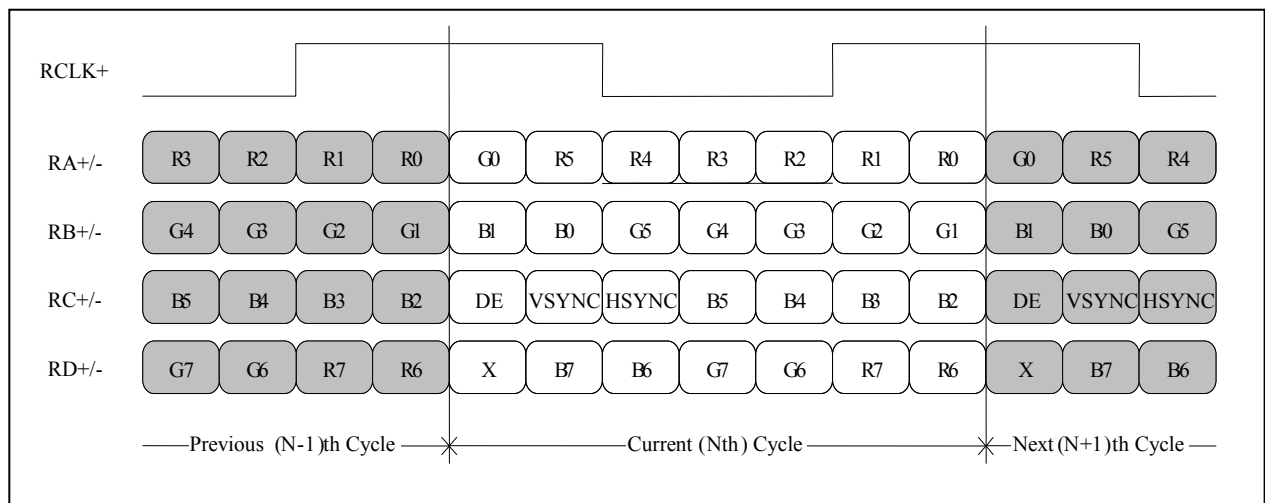

< LVDS Data Format >

3-4. Signal Timing Specifications

This is the signal timing required at the input of the User connector. All of the interface signal timing should be satisfied with the following specifications and specifications of LVDS Tx/Rx for its proper operation.

Table 5. TIMING TABLE

ITEM	Symbol	Min	Typ	Max	Unit	Note
DCLK	Frequency	f_{CLK}	67.5	71.0	74.5	MHz
Hsync	Period	T_{hp}	1366	1440	1488	tCLK
	Width	t_{WH}	16	32	48	
	Width-Active	t_{WHA}	1280	1280	1280	
Vsync	Period	t_{VP}	811	823	847	tHP
	Width	t_{WV}	3	6	9	
	Width-Active	t_{WVA}	800	800	800	
Data Enable	Horizontal back porch	t_{HBP}	54	80	98	tCLK
	Horizontal front porch	t_{HFP}	16	48	62	
	Vertical back porch	t_{VBP}	7	15	35	tHP
	Vertical front porch	t_{VFP}	1	2	3	

3-5. Signal Timing Waveforms

Condition : VCC = 3.3V

Data Enable, Hsync, Vsync

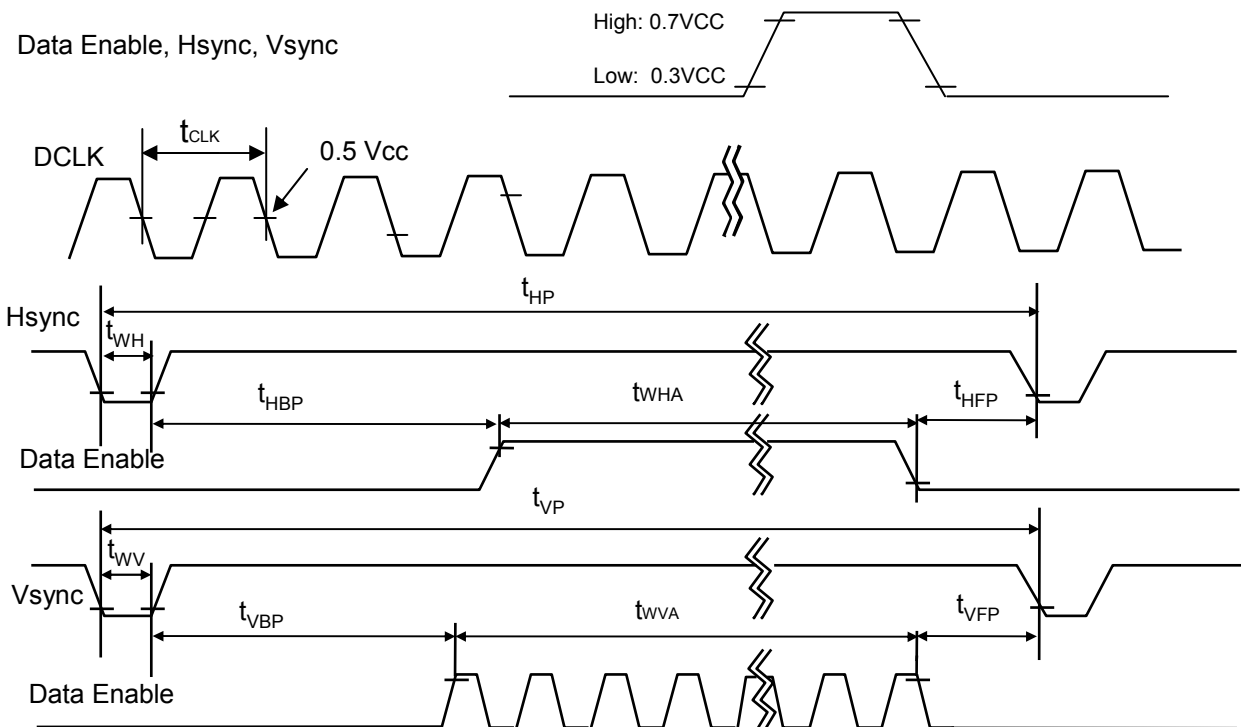

Product Specification

3-7. Power Sequence for LCD

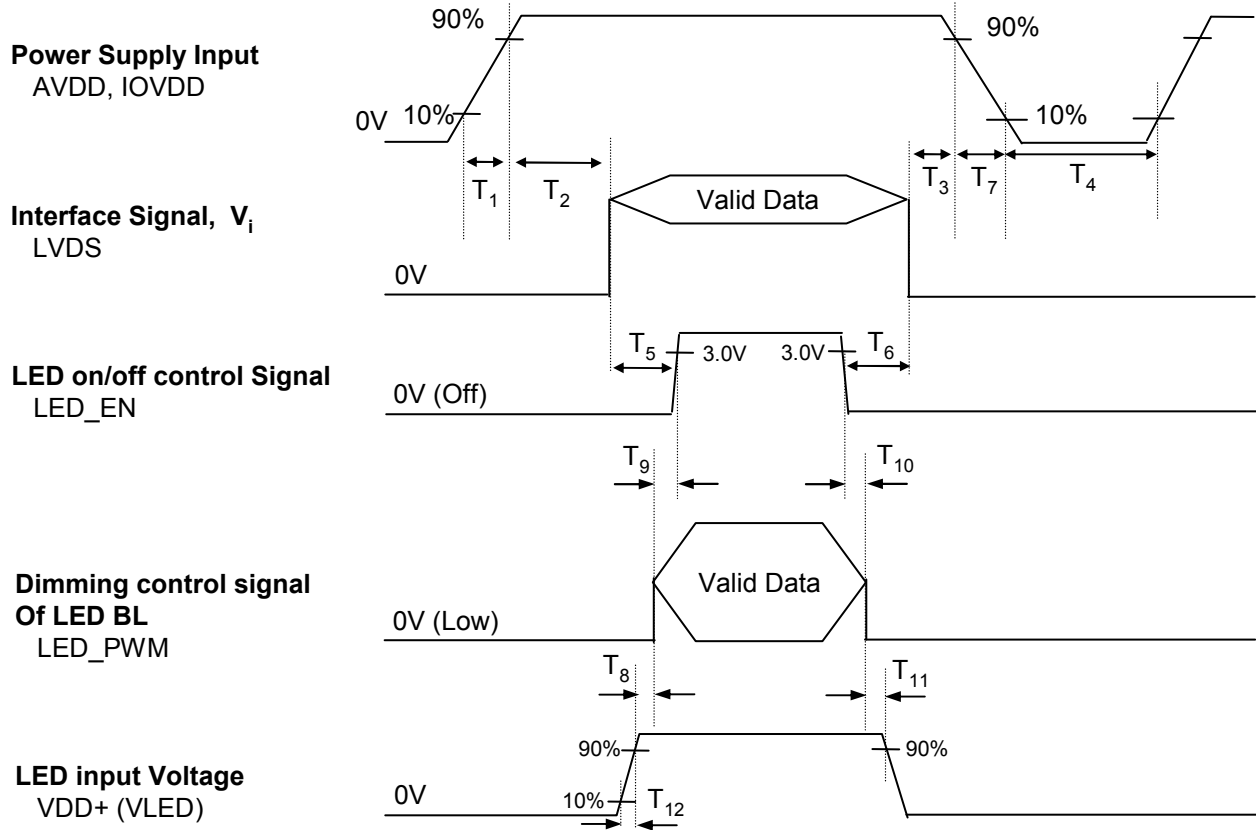

Table 6. POWER SEQUENCE TABLE

Logic Parameter	Value			Units	LED Parameter	Value			Units
	Min.	Typ.	Max.			Min.	Typ.	Max.	
T ₁	0.5	-	10	ms	T ₈	10	-	-	ms
T ₂	0	-	50	ms	T ₉	0	-	-	ms
T ₃	0	-	50	ms	T ₁₀	0	-	-	ms
T ₄	400	-	-	ms	T ₁₁	10	-	-	ms
T ₅	200	-	-	ms	T ₁₂	0.5	-	-	ms
T ₆	200	-	-	ms					
T ₇	3	-	10	ms					

Note)

1. Do not insert the mating cable when system turn on.
2. Valid Data have to meet "3-3. LVDS Signal Timing Specifications"
3. LVDS, LED_EN and PWM need to be on pull-down condition on invalid status.
4. LGD recommend the rising sequence of VLED after the Vcc and valid status of LVDS turn on.

Product Specification

4. Optical Specification

Optical characteristics are determined after the unit has been 'ON' and stable for approximately 30 minutes in a dark environment at 25°C. The values specified are at an approximate distance 50cm from the LCD surface at a viewing angle of Φ and Θ equal to 0°.

FIG. 1 presents additional information concerning the measurement equipment and method.

FIG. 1 Optical Characteristic Measurement Equipment and Method

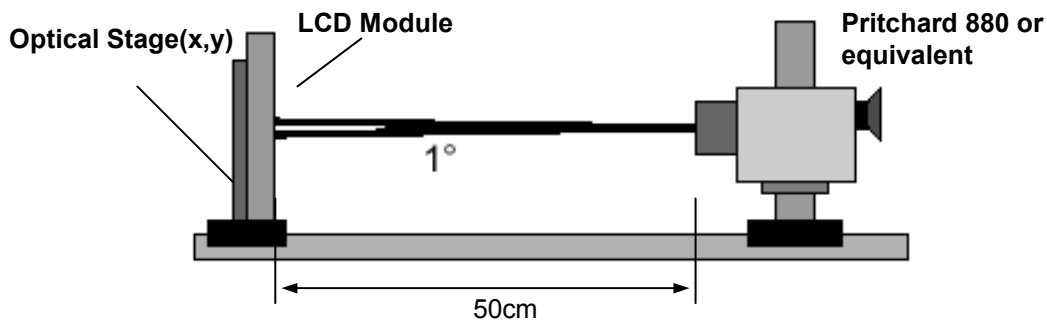

Table 8. OPTICAL CHARACTERISTICS

Ta=25°C, VCC=3.3V, fv=60Hz, fCLK= 69.4 MHz

Parameter	Symbol	Values			Units	Notes
		Min	Typ	Max		
Contrast Ratio	CR	500	700	-		1
Surface Luminance, white	w/o TSP L _{WH}	320	400	-	cd/m ²	2
	w/ TSP L _{WH}	80	90			
Luminance Variation	δ_{WHITE}	70	80			3
Response Time	T _R + T _D	-	35	50	ms	4
Color Coordinates(w/o TSP)						
RED	RX	0.565	0.595	0.625		
	RY	0.322	0.352	0.382		
GREEN	GX	0.305	0.335	0.365		
	GY	0.530	0.560	0.590		
BLUE	BX	0.126	0.156	0.186		
	BY	0.089	0.119	0.149		
WHITE	WX	0.280	0.310	0.340		
	WY	0.295	0.325	0.355		
Viewing Angle						
x axis, right($\Phi=0^\circ$)	Θ_r	80	-	-	degree	5
x axis, left ($\Phi=180^\circ$)	Θ_l	80	-	-	degree	
y axis, up ($\Phi=90^\circ$)	Θ_u	80	-	-	degree	
y axis, down ($\Phi=270^\circ$)	Θ_d	80	-	-	degree	
Gray Scale		2.2	2.5	2.8		

Product Specification

Note)

1. Contrast Ratio(CR) is defined mathematically as

$$\text{Contrast Ratio} = \frac{\text{Surface Luminance with all white pixels}}{\text{Surface Luminance with all black pixels}}$$

2. Surface luminance is the average of 5 point across the LCD surface 50cm from the surface with all pixels displaying white. For more information see FIG 1.

$$L_{WH} = \text{Average}(L_1, L_2, \dots L_5)$$

3. The variation in surface luminance, the panel variation (δ_5) is determined by measuring L_N at each test position 1 through 13 and then defined as followed numerical formula. For more information see FIG 2.

$$\delta_5 = \frac{\text{Minimum}(L_1, L_2, \dots L_5)}{\text{Maximum}(L_1, L_2, \dots L_5)}$$

The panel variation (δ_{13}) is determined by measuring L_N at each test position 1 through 13 and then defined as followed numerical formula. For more information see FIG 2.

$$\delta_{13} = \frac{\text{Minimum}(L_1, L_2, \dots L_{13})}{\text{Maximum}(L_1, L_2, \dots L_{13})}$$

4. Response time is the time required for the display to transition from white to black (rise time, Tr_R) and from black to white(Decay Time, Tr_D). For additional information see FIG 3.

5. Viewing angle is the angle at which the contrast ratio is greater than 100. The angles are determined for the horizontal or x axis and the vertical or y axis with respect to the z axis which is normal to the LCD surface. For more information see FIG 4.

Product Specification

5. Mechanical Characteristics

The contents provide general mechanical characteristics for the model LD101WX1. In addition the figures in the next page are detailed mechanical drawing of the LCD.

Outline Dimension	Horizontal	228.96 ± 0.2mm
	Vertical	148.5 ± 0.2mm
	Thickness	2.50mm (max), 4.8mm w/ PCB (max)
Active Display Area	Horizontal	216.96 mm
	Vertical	135.60 mm
Weight	145g (Max.) (TBD)	
Surface Treatment	Hard coating	

Product Specification

<FRONT VIEW_LCM>

Note) Unit:[mm], General tolerance: $\pm 0.3\text{mm}$

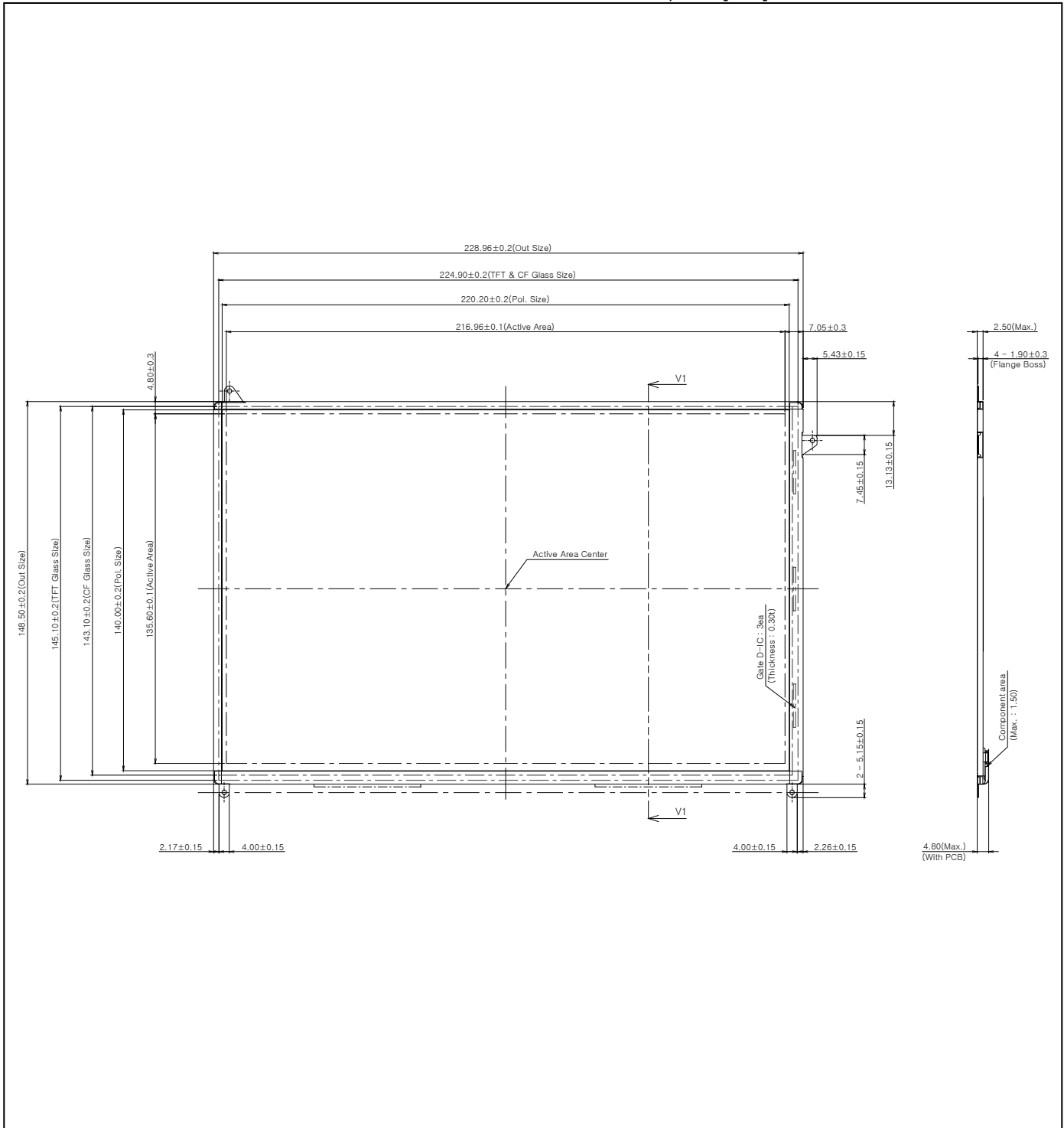

Product Specification

6. Reliability

Environment test condition

No.	Test Item	Conditions
1	High temperature storage test	Ta= 60°C, 240h
2	Low temperature storage test	Ta= -20°C, 240h
3	High temperature operation test	Ta= 50°C, 50%RH, 240h
4	Low temperature operation test	Ta= 0°C, 240h
5	Thermal shock (non-operating)	-10~60°C, 100Cycle
6	Altitude (non-operating)	40,000ft, room temperature, 24Hrs
7	Sine Vibration test (non-operating)	Sine wave, 10 ~ 500 ~ 10Hz, 1.5G, 0.37oct/min 3 axis, 1hour/axis
8	Random Vibration test (non-operating)	Random, 1.5Grms, Z axis 1hr
9	Shock test (non-operating)	Half sine wave, 180G, 2ms one shock of each six faces(I.e. run 180G 6ms for all six faces)

{ Result Evaluation Criteria }

There should be no change which might affect the practical display function when the display quality test is conducted under normal operating condition.

7. International Standards

7-1. Safety

- a) UL 60950-1, Second Edition, Underwriters Laboratories Inc.
Information Technology Equipment - Safety - Part 1 : General Requirements.
- b) CAN/CSA C22.2 No.60950-1-07, Second Edition, Canadian Standards Association.
Information Technology Equipment - Safety - Part 1 : General Requirements.
- c) EN 60950-1:2006 + A11:2009, European Committee for Electrotechnical Standardization (CENELEC).
Information Technology Equipment - Safety - Part 1 : General Requirements.
- d) IEC 60950-1:2005, Second Edition, The International Electrotechnical Commission (IEC).
Information Technology Equipment - Safety - Part 1 : General Requirements.

7-2. EMC

- a) ANSI C63.4 "American National Standard for Methods of Measurement of Radio-Noise Emissions from Low-Voltage Electrical and Electronic Equipment in the Range of 9 kHz to 40 GHz." American National Standards Institute (ANSI), 2003.
- b) CISPR 22 "Information technology equipment – Radio disturbance characteristics – Limit and methods of measurement." International Special Committee on Radio Interference (CISPR), 2005.
- c) CISPR 13 "Sound and television broadcast receivers and associated equipment – Radio disturbance characteristics – Limits and method of measurement." International Special Committee on Radio Interference (CISPR), 2006.

7-3. Environment

- a) RoHS, Directive 2002/95/EC of the European Parliament and of the council of 27 January 2003

Product Specification

8. Packing

8-1. Designation of Lot Mark

a) Lot Mark

A	B	C	D	E	F	G	H	I	J	K	L	M
---	---	---	---	---	---	---	---	---	---	---	---	---

A,B,C : SIZE(INCH)

E : MONTH

D : YEAR

F ~ M : SERIAL NO.

Note

1. YEAR

Year	2011	2012	2013	2014	2015	2016	2017	2018	2019	2020
Mark	A	B	C	D	E	F	G	H	J	K

2. MONTH

Month	Jan	Feb	Mar	Apr	May	Jun	Jul	Aug	Sep	Oct	Nov	Dec
Mark	1	2	3	4	5	6	7	8	9	A	B	C

b) Location of Lot Mark

Serial No. is printed on the label. The label is attached to the backside of the LCD module.
 This is subject to change without prior notice.

8-2. Packing Form

a) Package quantity in one box : **TBD** pcs

b) Box Size : **TBD**

9. PRECAUTIONS

Please pay attention to the followings when you use this TFT LCD module.

9-1. MOUNTING PRECAUTIONS

- (1) You must mount a module using holes arranged in four corners or four sides.
- (2) You should consider the mounting structure so that uneven force (ex. Twisted stress) is not applied to the module. And the case on which a module is mounted should have sufficient strength so that external force is not transmitted directly to the module.
- (3) Please attach the surface transparent protective plate to the surface in order to protect the polarizer. Transparent protective plate should have sufficient strength in order to resist external force.
- (4) You should adopt radiation structure to satisfy the temperature specification.
- (5) Acetic acid type and chlorine type materials for the cover case are not desirable because the former generates corrosive gas of attacking the polarizer at high temperature and the latter causes circuit break by electro-chemical reaction.
- (6) Do not touch, push or rub the exposed polarizers with glass, tweezers or anything harder than HB pencil lead. And please do not rub with dust clothes with chemical treatment. Do not touch the surface of polarizer for bare hand or greasy cloth. (Some cosmetics are detrimental to the polarizer.)
- (7) When the surface becomes dusty, please wipe gently with absorbent cotton or other soft materials like chamois soaks with petroleum benzene. Normal-hexane is recommended for cleaning the adhesives used to attach front / rear polarizers. Do not use acetone, toluene and alcohol because they cause chemical damage to the polarizer.
- (8) Wipe off saliva or water drops as soon as possible. Their long time contact with polarizer causes deformations and color fading.
- (9) Do not open the case because inside circuits do not have sufficient strength.

9-2. OPERATING PRECAUTIONS

- (1) The spike noise causes the mis-operation of circuits. It should be lower than following voltage :
 $V = \pm 200\text{mV}$ (Over and under shoot voltage)
- (2) Response time depends on the temperature. (In lower temperature, it becomes longer.)
- (3) Brightness depends on the temperature. (In lower temperature, it becomes lower.)
And in lower temperature, response time (required time that brightness is stable after turned on) becomes longer.
- (4) Be careful for condensation at sudden temperature change. Condensation makes damage to polarizer or electrical contacted parts. And after fading condensation, smear or spot will occur.
- (5) When fixed patterns are displayed for a long time, remnant image is likely to occur.
- (6) Module has high frequency circuits. Sufficient suppression to the electromagnetic interference shall be done by system manufacturers. Grounding and shielding methods may be important to minimize the interference.

9-3. ELECTROSTATIC DISCHARGE CONTROL

Since a module is composed of electronic circuits, it is not strong to electrostatic discharge. Make certain that treatment persons are connected to ground through wrist band etc. And don't touch interface pin directly.

9-4. PRECAUTIONS FOR STRONG LIGHT EXPOSURE

Strong light exposure causes degradation of polarizer and color filter.

9-5. STORAGE

When storing modules as spares for a long time, the following precautions are necessary.

- (1) Store them in a dark place. Do not expose the module to sunlight or fluorescent light. Keep the temperature between 5°C and 35°C at normal humidity.
- (2) The polarizer surface should not come in contact with any other object.
It is recommended that they be stored in the container in which they were shipped.

9-6. HANDLING PRECAUTIONS FOR PROTECTION FILM

- (1) When the protection film is peeled off, static electricity is generated between the film and polarizer.
This should be peeled off slowly and carefully by people who are electrically grounded and with well ion-blown equipment or in such a condition, etc.
- (2) The protection film is attached to the polarizer with a small amount of glue. If some stress is applied to rub the protection film against the polarizer during the time you peel off the film, the glue is apt to remain on the polarizer.
Please carefully peel off the protection film without rubbing it against the polarizer.
- (3) When the module with protection film attached is stored for a long time, sometimes there remains a very small amount of glue still on the polarizer after the protection film is peeled off.
- (4) You can remove the glue easily. When the glue remains on the polarizer surface or its vestige is recognized, please wipe them off with absorbent cotton waste or other soft material like chamois soaked with normal-hexane.

Product Specification

APPENDIX A. Enhanced Extended Display Identification Data (EEDID™) 1/3

	Byte (Dec)	Byte (Hex)	Field Name and Comments	Value (Hex)	Value (Bin)
Header	0	00	Header	00	00000000
	1	01	Header	FF	11111111
	2	02	Header	FF	11111111
	3	03	Header	FF	11111111
	4	04	Header	FF	11111111
	5	05	Header	FF	11111111
	6	06	Header	FF	11111111
	7	07	Header	00	00000000
Vendor / Product EDID Version	8	08	EISA manufacture code (3 Character ID) LGD	30	00110000
	9	09	EISA manufacture code (Compressed ASC II)	E4	11100100
	10	0A	Panel Supplier Reserved - Product Code 0330h	30	00110000
	11	0B	(Hex. LSB first)	03	00000011
	12	0C	LCD Module Serial No - Preferred but Optional ("0" if not used)	00	00000000
	13	0D	LCD Module Serial No - Preferred but Optional ("0" if not used)	00	00000000
	14	0E	LCD Module Serial No - Preferred but Optional ("0" if not used)	00	00000000
	15	0F	LCD Module Serial No - Preferred but Optional ("0" if not used)	00	00000000
	16	10	Week of Manufacture 00 weeks	00	00000000
	17	11	Year of Manufacture 2011 years	15	00010101
18	12	EDID structure version # = 1	01	00000001	
19	13	EDID revision # = 3	03	00000011	
Display Parameters	20	14	Video input Definition = Digital signal	80	10000000
	21	15	Max H image size (Rounded cm) = 22 cm	16	00010110
	22	16	Max V image size (Rounded cm) = 13 cm	0D	00001101
	23	17	Display gamma = (gamma*100)-100 = Example:(2.2*100)-100=120 = 2.2 Gamma	78	01111000
	24	18	Feature Support (no_DPMS, no_Active Off/Very Low Power, RGB color display, Timing BLK 1,no_GTF)	0A	00001010
Panel Color Coordinates	25	19	Red/Green Low Bits (Rx/Ry/Gx/Gy)	05	00000101
	26	1A	Blue/White Low Bits (Bx/By/Wx/Wy)	85	10000101
	27	1B	Red X Rx = 0.605	9B	10011011
	28	1C	Red Y Ry = 0.355	5B	01011011
	29	1D	Green X Gx = 0.329	54	01010100
	30	1E	Green Y Gy = 0.579	94	10010100
	31	1F	Blue X Bx = 0.150	26	00100110
	32	20	Blue Y By = 0.055	0E	00001110
33	21	White X Wx = 0.313	50	01010000	
34	22	White Y Wy = 0.329	54	01010100	
Established Timings	35	23	Established timing 1 (00h if not used)	00	00000000
	36	24	Established timing 2 (00h if not used)	00	00000000
	37	25	Manufacturer's timings (00h if not used)	00	00000000
Standard Timing ID	38	26	Standard timing ID1 (01h if not used)	01	00000001
	39	27	Standard timing ID1 (01h if not used)	01	00000001
	40	28	Standard timing ID2 (01h if not used)	01	00000001
	41	29	Standard timing ID2 (01h if not used)	01	00000001
	42	2A	Standard timing ID3 (01h if not used)	01	00000001
	43	2B	Standard timing ID3 (01h if not used)	01	00000001
	44	2C	Standard timing ID4 (01h if not used)	01	00000001
	45	2D	Standard timing ID4 (01h if not used)	01	00000001
	46	2E	Standard timing ID5 (01h if not used)	01	00000001
	47	2F	Standard timing ID5 (01h if not used)	01	00000001
	48	30	Standard timing ID6 (01h if not used)	01	00000001
	49	31	Standard timing ID6 (01h if not used)	01	00000001
	50	32	Standard timing ID7 (01h if not used)	01	00000001
	51	33	Standard timing ID7 (01h if not used)	01	00000001
	52	34	Standard timing ID8 (01h if not used)	01	00000001
	53	35	Standard timing ID8 (01h if not used)	01	00000001

Product Specification

APPENDIX A. Enhanced Extended Display Identification Data (EEDID™) 2/3

	Byte (Dec)	Byte (Hex)	Field Name and Comments	Value (Hex)	Value (Bin)	
Timing Descriptor #1	54	36	Pixel Clock/10,000 (LSE) 71 MHz@ 59.9Hz	BC	10111100	
	55	37	Pixel Clock/10,000 (MSE)	1B	00011011	
	56	38	Horizontal Active (lower 8 bits) 1280 Pixels	00	00000000	
	57	39	Horizontal Blanking(Thp-HA) (lower 8 bits) 160 Pixels	A0	10100000	
	58	3A	Horizontal Active / Horizontal Blanking(Thp-HA) (upper 4.4bits)	50	01010000	
	59	3B	Vertical Active 800 Lines	20	00100000	
	60	3C	Vertical Blanking (Tvp-HA) (DE Blanking typ for DE only panels) 23 Lines	17	00010111	
	61	3D	Vertical Active : Vertical Blanking (Tvp-HA) (upper 4.4bits)	30	00110000	
	62	3E	Horizontal Sync. Offset (Thfp) 48 Pixels	30	00110000	
	63	3F	Horizontal Sync Pulse Width (HSPW) 32 Pixels	20	00100000	
	64	40	Vertical Sync Offset(Tvfp) : Sync Width (VSPW) 3 Lines : 5 Lines	35	00110101	
	65	41	Horizontal Vertical Sync Offset/Width (upper 2bits)	00	00000000	
	66	42	Horizontal Image Size (mm) 223 mm	DF	11011111	
	67	43	Vertical Image Size (mm) 125 mm	7D	01111101	
	68	44	Horizontal Image Size / Vertical Image Size	00	00000000	
	69	45	Horizontal Border = 0 (Zero for Notebook LCD)	00	00000000	
	70	46	Vertical Border = 0 (Zero for Notebook LCD)	00	00000000	
	71	47	Non-Interlace, Normal display, no stereo, Digital Separate (Vsync_NEG, Hsync_POS), DE only note : LSB is set to '1' if panel is DE-timing only. H/V can be ignored.	1B	00011011	
	Timing Descriptor #2	72	48	Pixel Clock/10,000 (LSE) 59.26 MHz@ 50Hz	26	00100110
		73	49	Pixel Clock/10,000 (MSE)	17	00010111
		74	4A	Horizontal Active (lower 8 bits) 1280 Pixels	00	00000000
75		4B	Horizontal Blanking(Thp-HA) (lower 8 bits) 160 Pixels	A0	10100000	
76		4C	Horizontal Active / Horizontal Blanking(Thp-HA) (upper 4.4bits)	50	01010000	
77		4D	Vertical Active 800 Lines	20	00100000	
78		4E	Vertical Blanking (Tvp-HA) (DE Blanking typ for DE only panels) 23 Lines	17	00010111	
79		4F	Vertical Active : Vertical Blanking (Tvp-HA) (upper 4.4bits)	30	00110000	
80		50	Horizontal Sync. Offset (Thfp) 48 Pixels	30	00110000	
81		51	Horizontal Sync Pulse Width (HSPW) 32 Pixels	20	00100000	
82		52	Vertical Sync Offset(Tvfp) : Sync Width (VSPW) 3 Lines : 5 Lines	35	00110101	
83		53	Horizontal Vertical Sync Offset/Width (upper 2bits)	00	00000000	
84		54	Horizontal Image Size (mm) 223 mm	DF	11011111	
85		55	Vertical Image Size (mm) 125 mm	7D	01111101	
86		56	Horizontal Image Size / Vertical Image Size	00	00000000	
87		57	Horizontal Border = 0 (Zero for Notebook LCD)	00	00000000	
88		58	Vertical Border = 0 (Zero for Notebook LCD)	00	00000000	
89		59	Non-Interlace, Normal display, no stereo, Digital Separate (Vsync_NEG, Hsync_POS), DE only note : LSB is set to '1' if panel is DE-timing only. H/V can be ignored.	1B	00011011	
Timing Descriptor #3	90	5A	Flag	00	00000000	
	91	5B	Flag	00	00000000	
	92	5C	Flag	00	00000000	
	93	5D	Data Type Tag (ASCII String)	FE	11111110	
	94	5E	Flag	00	00000000	
	95	5F	ASCII String L	4C	01001100	
	96	60	ASCII String G	47	01000111	
	97	61	ASCII String	20	00100000	
	98	62	ASCII String D	44	01000100	
	99	63	ASCII String i	69	01101001	
	100	64	ASCII String s	73	01110011	
	101	65	ASCII String p	70	01110000	
	102	66	ASCII String l	6C	01101100	
	103	67	ASCII String a	61	01100001	
	104	68	ASCII String y	79	01111001	
	105	69	Manufacturer P/N(IF<13 char-> 0Ah, then terminate with ASC II code 0Ah,set remaining char = 20h)	0A	00001010	
	106	6A	Manufacturer P/N(IF<13 char-> 0Ah, then terminate with ASC II code 0Ah,set remaining char = 20h)	20	00100000	
	107	6B	Manufacturer P/N(IF<13 char-> 0Ah, then terminate with ASC II code 0Ah,set remaining char = 20h)	20	00100000	

TBD

APPENDIX A. Enhanced Extended Display Identification Data (EEDID™) 3/3

	Byte (Dec)	Byte (Hex)	Field Name and Comments	Value (Hex)	Value (Bin)
Timing Descriptor #4	108	6C	Flag	00	00000000
	109	6D	Flag	00	00000000
	110	6E	Flag	00	00000000
	111	6F	Data Type Tag (ASCII String)	FE	11111110
	112	70	Flag	00	00000000
	113	71	ASCII String	L	01001100
	114	72	ASCII String	D	01000100
	115	73	ASCII String	1	00110001
	116	74	ASCII String	0	00110000
	117	75	ASCII String	1	00110001
	118	76	ASCII String	W	01010111
	119	77	ASCII String	X	01011000
	120	78	ASCII String	1	00110001
	121	79	ASCII String	-	00101101
	122	7A	ASCII String	S	01010011
	123	7B	ASCII String	L	01001100
	124	7C	ASCII String	0	00110000
125	7D	ASCII String	1	00110001	
Checksum	126	7E	Extension flag (# of optional 128 panel ID extension block to follow, Typ = 0)	00	00000000
	127	7F	Check Sum (The 1-byte sum of all 128 bytes in this panel ID block shall = 0)	79	01111001