

TFT-Display Datenblatt

Modell LD420WXN-SAA1

Kurzdaten

| | |
|------------|---------------------------|
| Hersteller | LG Display |
| Diagonale | 42,0" / 106,7cm |
| Format | 16:9 |
| Auflösung | 1366x768 |
| Backlight | EEFL/500cd/m ² |
| Temperatur | 0...+50°C (Betrieb) |

Product Specification

SPECIFICATION FOR APPROVAL

- (●) Preliminary Specification
() Final Specification

| | |
|--------------|---------------------------|
| Title | 42.0" WXGA TFT LCD |
|--------------|---------------------------|

| | |
|-------|--|
| BUYER | |
| MODEL | |

| | |
|----------|--------------------------|
| SUPPLIER | LG.Philips LCD Co., Ltd. |
| *MODEL | LD420WXN |
| SUFFIX | SAA1 |

*When you obtain standard approval,
please use the above model name without suffix

| APPROVED BY | SIGNATURE DATE |
|-------------|----------------|
| / | |
| / | |
| / | |

Please return 1 copy for your confirmation with your signature and comments.

| APPROVED BY | SIGNATURE DATE |
|------------------------|----------------|
| Y. S Park / S. Manager | |
| REVIEWED BY | |
| M. K Lee / Manager | |
| PREPARED BY | |
| J. H Kim / Engineer | |

**TV Products Development Dept.
LG. Philips LCD Co., Ltd**

Product Specification

CONTENTS

| Number | ITEM | Page |
|--------|--|------|
| | COVER | 1 |
| | CONTENTS | 2 |
| | RECORD OF REVISIONS | 3 |
| 1 | GENERAL DESCRIPTION | 4 |
| 2 | ABSOLUTE MAXIMUM RATINGS | 5 |
| 3 | ELECTRICAL SPECIFICATIONS | 6 |
| 3-1 | ELECTRICAL CHARACTERISTICS | 6 |
| 3-2 | INTERFACE CONNECTIONS | 8 |
| 3-3 | SIGNAL TIMING SPECIFICATIONS | 10 |
| 3-4 | SIGNAL TIMING WAVEFORMS | 11 |
| 3-5 | COLOR DATA REFERENCE | 12 |
| 3-6 | POWER SEQUENCE | 13 |
| 4 | OPTICAL SPECIFICATIONS | 15 |
| 5 | MECHANICAL CHARACTERISTICS | 20 |
| 6 | RELIABILITY | 22 |
| 7 | INTERNATIONAL STANDARDS | 23 |
| 7-1 | SAFETY | 23 |
| 7-2 | EMC | 23 |
| 8 | PACKING | 24 |
| 8-1 | DESIGNATION OF LOT MARK | 24 |
| 8-2 | PACKING FORM | 24 |
| 9 | PRECAUTIONS | 25 |
| 9-1 | MOUNTING PRECAUTIONS | 25 |
| 9-2 | OPERATING PRECAUTIONS | 25 |
| 9-3 | ELECTROSTATIC DISCHARGE CONTROL | 26 |
| 9-4 | PRECAUTIONS FOR STRONG LIGHT EXPOSURE | 26 |
| 9-5 | STORAGE | 26 |
| 9-6 | HANDLING PRECAUTIONS FOR PROTECTION FILM | 26 |
| 9-7 | APPROPRIATE CONDITION FOR PUBLIC DISPLAY | 26 |

Product Specification

1. General Description

The LC420WXN is a Color Active Matrix Liquid Crystal Display with an integral External Electrode Fluorescent Lamp (EEFL) backlight system. The matrix employs a-Si Thin Film Transistor as the active element. It is a transmissive type display operating in the normally black mode. It has a 42.0 inch diagonally measured active display area with WXGA resolution (768 vertical by 1366 horizontal pixel array). Each pixel is divided into Red, Green and Blue sub-pixels or dots which are arranged in vertical stripes. Gray scale or the luminance of the sub-pixel color is determined with a 8-bit gray scale signal for each dot, thus presenting a palette of more than 16.7M(true) colors.

It has been designed to apply the 8-bit 1-port LVDS interface.

It is intended to support LCD TV, PCTV where high brightness, super wide viewing angle, high color gamut, high color depth and fast response time are important.

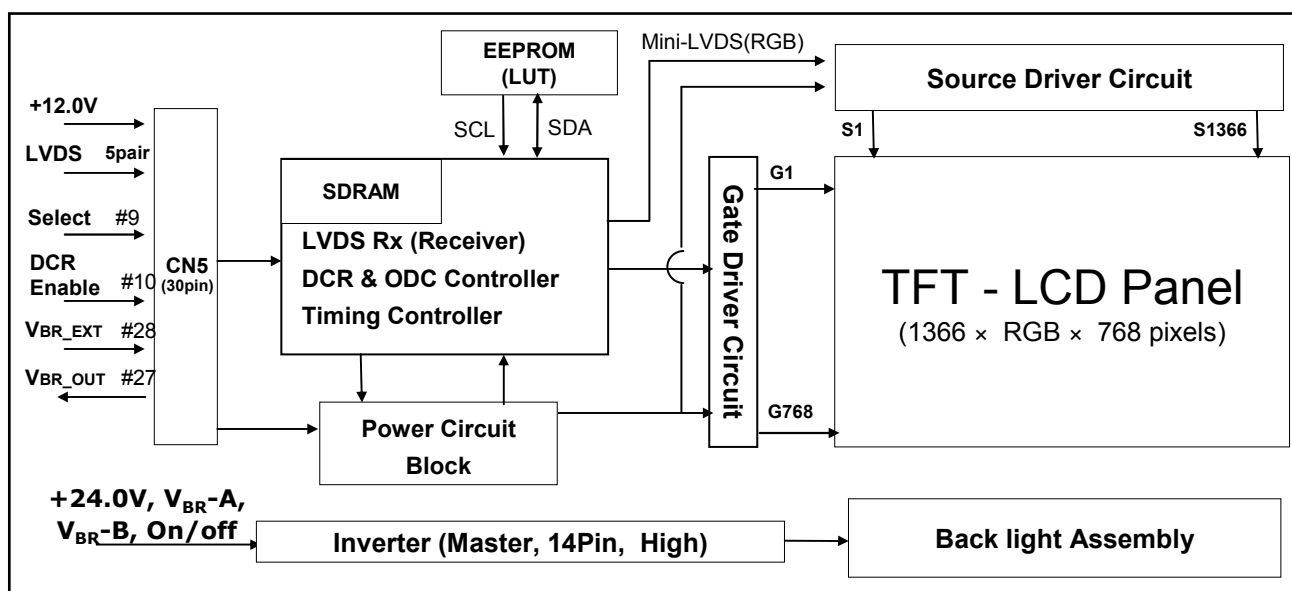

General Features

| | |
|------------------------|--|
| Active Screen Size | 42.02 inches(1067.308mm) diagonal |
| Outline Dimension | 983 mm(H) x 576 mm(V) x 51 mm(D) (Typ.) |
| Pixel Pitch | 0.227mm x 0.681mm x RGB |
| Pixel Format | 1366 horiz. by 768 vert. Pixels RGB stripe arrangement |
| Color Depth | 8-bit, 16.7 M colors |
| Luminance, White | 500 cd/m ² (Center 1-point) (Typ.) |
| Viewing Angle (CR>10) | Viewing Angle Free (R/L 178 (Typ.), U/D 178 (Typ)) |
| Power Consumption | Total 165.4 W (Typ.) (Logic=5.40 W, Inverter=160W [VBR-A = 1.65V]) |
| Weight | 10.5 Kg (Typ.) |
| Display Operating Mode | Transmissive mode, Normally black |
| Surface Treatment | Hard coating(3H), Anti-glare treatment of the front polarizer (Haze 13%) |

Product Specification

2. Absolute Maximum Ratings

The following items are maximum values which, if exceeded, may cause faulty operation or damage to the LCD module.

Table 1. ABSOLUTE MAXIMUM RATINGS

| Parameter | | Symbol | Value | | Unit | Remark |
|----------------------------|-------------|------------------------------------|-------|-------|--------|--------------|
| | | | Min | Max | | |
| Power Input Voltage | LCD circuit | V _{LCD} | +8.0 | +14.0 | V [DC] | at 25 ± 2 °C |
| | Inverter | V _{BL} | -0.3 | 27.0 | V [DC] | |
| Inverter Control Voltage | ON/OFF | V _{OFF} / V _{ON} | -0.3 | +5.5 | V [DC] | |
| | Brightness | V _{BR} | 0.0 | +5.0 | V [DC] | |
| Operating Temperature | | T _{OP} | 0 | +50 | °C | Note 1 |
| Storage Temperature | | T _{ST} | -20 | +60 | °C | |
| Operating Ambient Humidity | | H _{OP} | 10 | 90 | %RH | |
| Storage Humidity | | H _{ST} | 10 | 90 | %RH | |

Note 1. Temperature and relative humidity range are shown in the figure below.
Wet bulb temperature should be 39 °C Max, and no condensation of water.

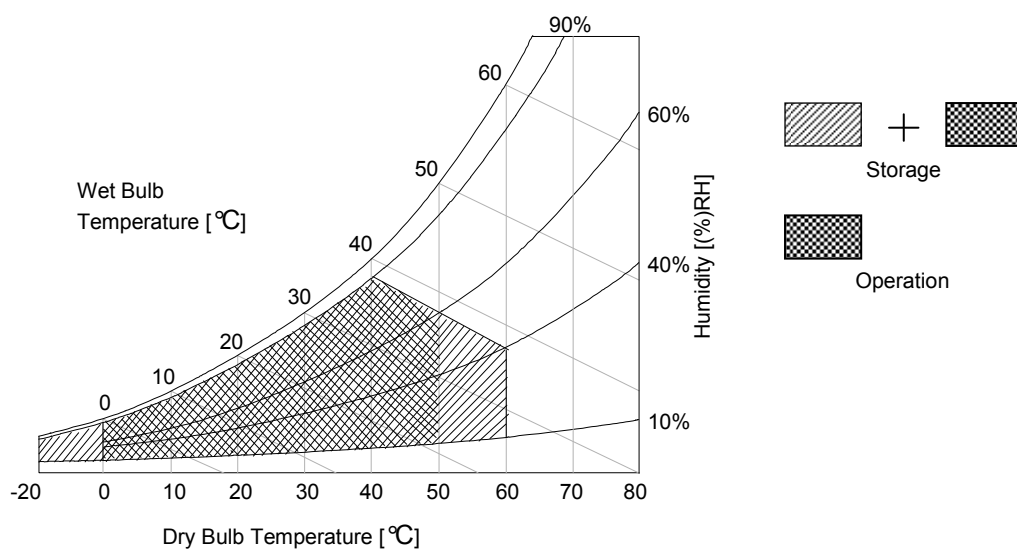

Product Specification

3. Electrical Specifications

3-1. Electrical Characteristics

It requires two power inputs. One is employed to power for the LCD circuit. The other input power for the EEFL/Backlight is to power inverter.

Table 2. ELECTRICAL CHARACTERISTICS

| Parameter | Symbol | Value | | | Unit | Note |
|---------------------|-------------------|-------|------|------|--------|------|
| | | Min | Typ | Max | | |
| Circuit : | | | | | | |
| Power Input Voltage | V _{LCD} | 11.4 | 12.0 | 12.6 | V [DC] | |
| Power Input Current | I _{LCD} | - | 450 | 585 | mA | 1 |
| | | - | 500 | 650 | mA | 2 |
| Power Consumption | P _{LCD} | | 5.4 | 7.0 | Watt | 1 |
| Rush current | I _{RUSH} | - | - | 3.0 | A | 3 |

- Note :
1. The specified current and power consumption are under the $V_{LCD}=12.0V$, $25 \pm 2^{\circ}C$, $f_V=60Hz$ condition whereas mosaic pattern(8 x 6) is displayed and f_V is the frame frequency.
 2. The current is specified at the maximum current pattern.
 3. The duration of rush current is about 2ms and rising time of power input is 1ms (min.).

White : 255Gray
Black : 0Gray

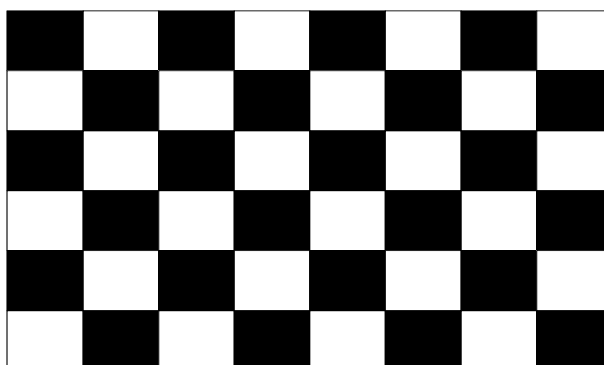

Mosaic Pattern(8 x 6)

Product Specification

Table 3. ELECTRICAL CHARACTERISTICS (Continue)

| Parameter | Symbol | Values | | | Unit | Notes | | |
|--|-------------------|--------|-------|------|------|--|---------------------|--|
| | | Min | Typ | Max | | | | |
| Inverter : | | | | | | | | |
| Power Supply Input Voltage | VBL | 22.8 | 24.0 | 25.2 | Vdc | 1 | | |
| Power Supply Input Voltage Ripple | | - | - | 0.5 | Vp-p | 1 | | |
| Power Supply Input Current | After Aging | IBL_A | - | 6.7 | 7.2 | A | VBR-A = 1.65V ... 1 | |
| | | | - | 7.2 | 7.7 | A | VBR-A = 3.30V ... 1 | |
| | Before Aging | IBL_B | - | 7.2 | 7.7 | A | VBR-A = 1.65V ... 2 | |
| | | | - | 7.7 | 8.2 | A | VBR-A = 3.30V ... 2 | |
| Power Supply Input Current (In-Rush) | Irush | - | - | 9.3 | A | VBL = 22.8V VBR-B = 3.3V VBR-A = 1.65V | | |
| Power Consumption | PBL | - | 160 | 172 | W | VBR-A = 1.65V ... 1 | | |
| Input Voltage for Control System Signals | Brightness Adjust | VBR-A | 0.0 | 1.65 | 3.3 | Vdc | | |
| | On/Off | On | V on | 2.5 | - | 5.0 | Vdc | |
| | | Off | V off | -0.3 | 0.0 | 0.8 | Vdc | |
| | Brightness Adjust | VBR-B | 0 | - | 3.3 | V | | |
| Lamp: | | | | | | | | |
| Discharge Stabilization Time | Ts | | | 3 | min | 3 | | |
| Life Time | | 50,000 | | | Hrs | 4 | | |

Notes :

- Electrical characteristics are determined after the unit has been 'ON' and stable for approximately 30 minutes at $25 \pm 2^\circ\text{C}$. The specified current and power consumption are under the typical supply Input voltage 24V and V_{BR} (V_{BR-A} : 1.65V & V_{BR-B} : 3.3V), it is total power consumption. The ripple voltage of the power supply input voltage is under 0.5 Vp-p. LPL recommend Input Voltage is $24.0V \pm 5\%$.
- Electrical characteristics are determined within 30 minutes at $25 \pm 2^\circ\text{C}$. The specified currents are under the typical supply Input voltage 24V.
- The brightness of the lamp after lighted for 5minutes is defined as 100%.
 T_s is the time required for the brightness of the center of the lamp to be not less than 95% at typical current. The screen of LCD module may be partially dark by the time the brightness of lamp is stable after turn on.
- Specified Values are for a single lamp which is aligned horizontally.
The life time is determined as the time which luminance of the lamp is 50% compared to that of initial value at the typical lamp current (V_{BR-A} : 1.65V & V_{BR-B} : 3.3V), on condition of continuous operating at $25 \pm 2^\circ\text{C}$
- LPL recommend that the PWM freq. is synchronized with Two times harmonic of Vsync signal of system.
- The duration of rush current is about 20ms.

Product Specification

3-2. Interface Connections

This LCD module employs two kinds of interface connection, a 30-pin connector is used for the module electronics and 14-pin connector is used for the integral backlight system.

3-2-1. LCD Module

- LCD Connector(CN5) : FI-X30SSL-HF (Manufactured by JAE) or Equivalent
- Mating Connector : FI-30C2L (Manufactured by JAE) or Equivalent

Table 4. MODULE CONNECTOR(CN5) PIN CONFIGURATION

| Pin No. | Symbol | Description | Note |
|---------|------------|--|------|
| 1 | VLCD | Power Supply +12.0V | |
| 2 | VLCD | Power Supply +12.0V | |
| 3 | VLCD | Power Supply +12.0V | |
| 4 | VLCD | Power Supply +12.0V | |
| 5 | GND | Ground | |
| 6 | GND | Ground | |
| 7 | GND | Ground | |
| 8 | GND | Ground | |
| 9 | Select | Select LVDS Data format | 1 |
| 10 | DCR Enable | Dynamic CR Enable ('L' = Disable , 'H' = Enable) | 2 |
| 11 | GND | Ground | |
| 12 | RA- | LVDS Receiver Signal(-) | |
| 13 | RA+ | LVDS Receiver Signal(+) | |
| 14 | GND | Ground | |
| 15 | RB- | LVDS Receiver Signal(-) | |
| 16 | RB+ | LVDS Receiver Signal(+) | |
| 17 | GND | Ground | |
| 18 | RC- | LVDS Receiver Signal(-) | |
| 19 | RC+ | LVDS Receiver Signal(+) | |
| 20 | GND | Ground | |
| 21 | RCLK- | LVDS Receiver Clock Signal(-) | |
| 22 | RCLK+ | LVDS Receiver Clock Signal(+) | |
| 23 | GND | Ground | |
| 24 | RD- | LVDS Receiver Signal(-) | |
| 25 | RD+ | LVDS Receiver Signal(+) | |
| 26 | GND | Ground | |
| 27 | VBR_OUT | VBR output form LCD module | |
| 28 | VBR_EXT | External VBR input from System to LCD module | |
| 29 | GND | Ground | |
| 30 | GND | Ground | 3 |

- Notes: 1. The pin no 9 is an option pin for DISM or LG format. (VESA Format = "GND" / JEIDA Format ="VCC")
Please refer to Appendix for further details.
2. The pin no 10 is an option pin for DCR Function (Enable = "VCC" / Disable ="GND")
3. The pin no 30 is LCD Test option.
LCM operates "AGP" (Auto Generation Pattern) or "NSB" (No Signal Black) is case that LVDS signals are out of frequency or abnormal condition in spite of 12 volt power supply.
LPL recommends "NSB". (AGP : "VCC" or "OPEN" / NSB : "GND")
4. All GND (ground) pins should be connected together, which should be also connected to the LCD module's metal frame.
5. All VLCD (power input) pins should be connected together.
6. Input Levels of LVDS signals are based on the IEA 664 Standard.

Product Specification

3-2-2. Backlight Inverter

- Inverter Connector : S14B-PH-SMC (JST) or Equivalent
- Mating Connector : PHR-14 or Equivalent

Table 5. INVERTER CONNECTOR PIN CONFIGURATION

| Pin No | Symbol | Description | Note |
|--------|--------|--|------|
| 1 | VBL | Power Supply +24.0V | |
| 2 | VBL | Power Supply +24.0V | |
| 3 | VBL | Power Supply +24.0V | |
| 4 | VBL | Power Supply +24.0V | |
| 5 | VBL | Power Supply +24.0V | |
| 6 | GND | Backlight Ground | 1 |
| 7 | GND | Backlight Ground | |
| 8 | GND | Backlight Ground | |
| 9 | GND | Backlight Ground | |
| 10 | GND | Backlight Ground | |
| 11 | VBR-A | Analog dimming voltage DC 0.0V ~ 3.3V (Typ : 1.65V) | 2, 3 |
| 12 | On/Off | 0.0V ~ 5.0V | |
| 13 | VBR-B | Burst dimming voltage DC 0.0V ~ 3.3V | 3 |
| 14 | Status | Normal : Upper 3.0V Abnormal : Under 0.7V | 4 |

- Notes :
1. GND should be connected to the LCD module's metal frame.
 2. If Pin #11 is open, VBR-A = 1.65V. When apply over 1.65V(~ 3.3V) continuously, its luminance is increasing however lamp's life time is decreasing.
It could be usable for boost up luminance when using DCR (=Dynamic contrast ratio) function only.
 3. Minimum Brightness : VBR-B =0V Maximum Brightness : VBR-B = 3.3V
 4. Even though Pin #14 is open, there is no effect on inverter operating, The output terminal of inverter.
 5. Each impedance of pin #11,12 and 13 is 300[k Ω], 80[k Ω], 75[k Ω]

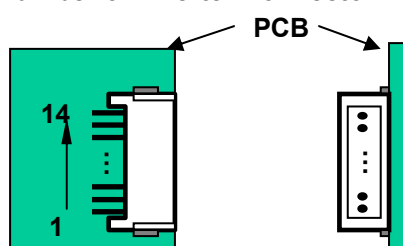
◆ Pin Number of Inverter Connector

Product Specification

3-3. Signal Timing Specifications

Table 6 and Table 7 show the signal timing required at the input of the LVDS transmitter. All of the interface signal timings should be satisfied with the following specification for normal operation.

Table 6. TIMING TABLE for NTSC &PAL**[DE (Data Enable) Only]**

| ITEM | Symbol | | Min | Typ | Max | Unit | Note |
|-------|------------------------|------|----------|------|----------|------|--|
| DCLK | Period | tCLK | 12.5 | 13.8 | 15.8 | ns | |
| | Frequency | - | 63 | 72.4 | 80 | MHz | |
| Hsync | Period | tHT | 1456 | 1528 | 1920 | tCLK | |
| | Horizontal Valid | tHV | 1366 | 1366 | 1366 | tCLK | |
| | Horizontal Blank | - | tHP- tHV | 162 | tHP- tHV | | |
| | Frequency | fH | 45 | 47.4 | 50 | KHz | |
| | Width | tWH | - | 32 | - | tCLK | |
| | Horizontal Back Porch | tHBP | 24 | 48 | - | | |
| | Horizontal Front Porch | tHFP | 40 | 80 | - | | |
| Vsync | Period | tVT | 776 | 790 | 1063 | tHP | |
| | Vertical Valid | tVV | 768 | 768 | 768 | tHP | |
| | Vertical Blank | - | tVP- tVV | 22 | tVP- tVV | tHP | |
| | Frequency | fV | 47 | 60 | 63 | Hz | Note 1) PAL : 47~53Hz NTSC : 57~63Hz |
| | Width | tWV | - | 5 | - | tHP | |
| | Vertical Back Porch | tVBP | 5 | 15 | - | Hz | |
| | Vertical Front Porch | tVFP | 1 | 2 | - | tHP | |

Note : 1. The Input of HSYNC & VSYNC signal does not have an effect on normal operation(DE Only Mode).

If you use spread spectrum for EMI, add some additional clock to minimum value for clock margin.

2. The performance of the electro-optical characteristics may be influenced by variance of the vertical refresh rate and the horizontal frequency.
3. Timing should be set based on clock frequency.

Product Specification

3-4. Signal Timing Waveforms

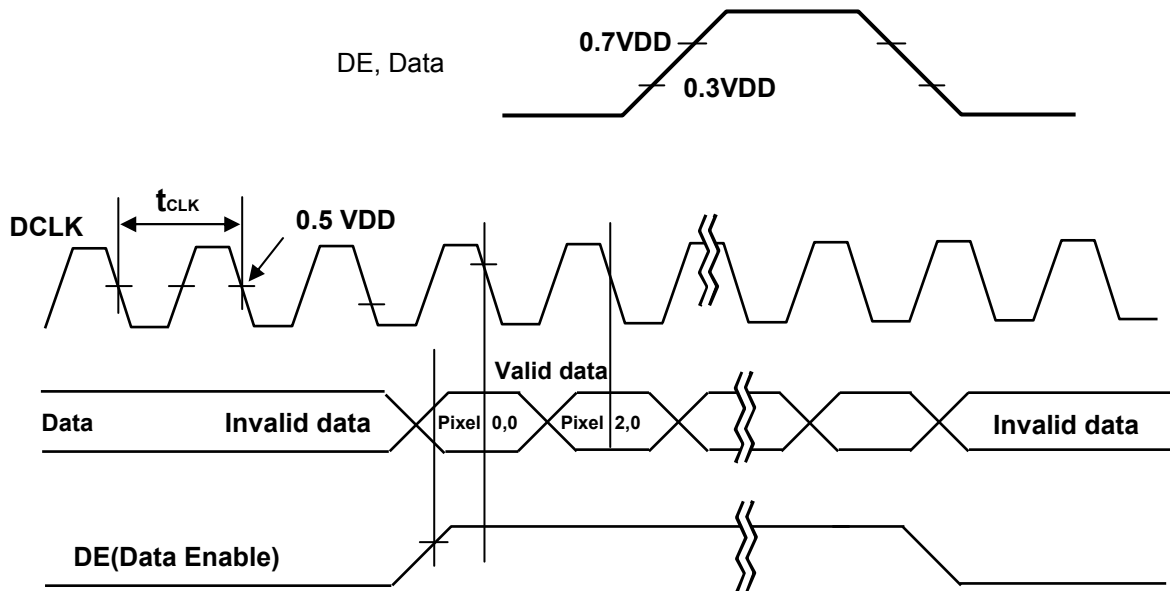

* Reference : Sync. Relation

* $t_{HB} = t_{HFP} + t_{WH} + t_{HBP}$

* $t_{VB} = t_{VFP} + t_{WV} + t_{VBP}$

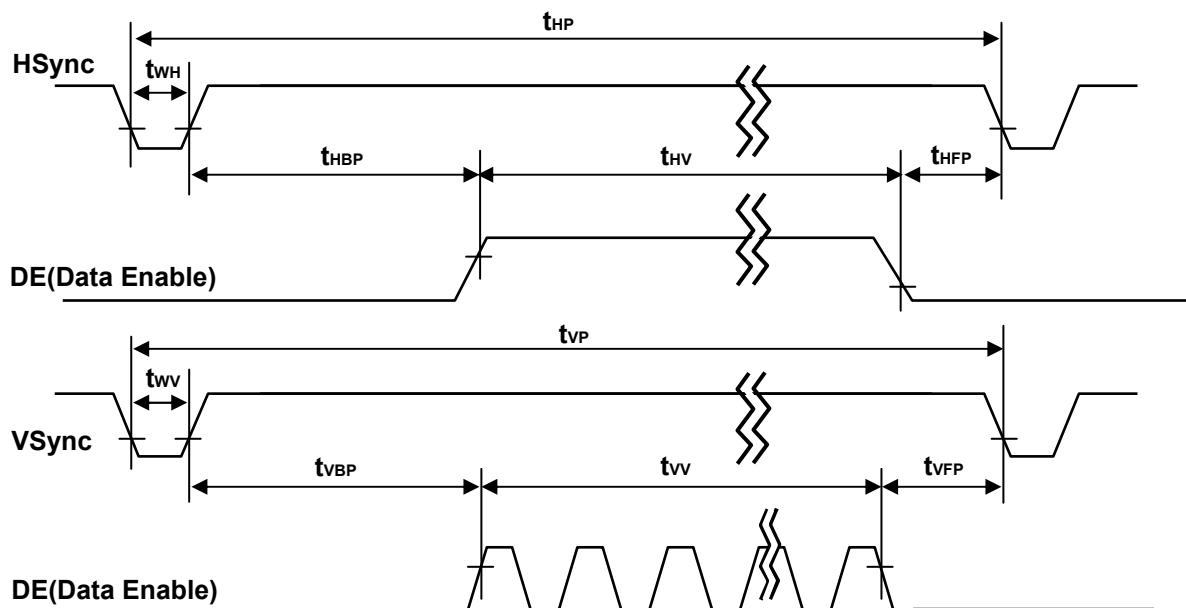

Product Specification

3-5. Color Data Reference

The brightness of each primary color(red,green,blue) is based on the 8-bit gray scale data input for the color. The higher binary input, the brighter the color. Table 8 provides a reference for color versus data input.

Table 7. COLOR DATA REFERENCE

| Color | | Input Color Data | | | | | | | | | | | | | | | | | | | | | | | |
|-------------|------------------|------------------|----|----|----|-----|----|----|----|-------|----|----|----|-----|----|----|----|------|----|----|----|-----|----|----|----|
| | | RED | | | | | | | | GREEN | | | | | | | | BLUE | | | | | | | |
| | | MSB | | | | LSB | | | | MSB | | | | LSB | | | | MSB | | | | LSB | | | |
| | | R7 | R6 | R5 | R4 | R3 | R2 | R1 | R0 | G7 | G6 | G5 | G4 | G3 | G2 | G1 | G0 | B7 | B6 | B5 | B4 | B3 | B2 | B1 | B0 |
| Basic Color | Black | 0 | 0 | 0 | 0 | 0 | 0 | 0 | 0 | 0 | 0 | 0 | 0 | 0 | 0 | 0 | 0 | 0 | 0 | 0 | 0 | 0 | 0 | 0 | 0 |
| | Red (255) | 1 | 1 | 1 | 1 | 1 | 1 | 1 | 1 | 0 | 0 | 0 | 0 | 0 | 0 | 0 | 0 | 0 | 0 | 0 | 0 | 0 | 0 | 0 | 0 |
| | Green (255) | 0 | 0 | 0 | 0 | 0 | 0 | 0 | 0 | 1 | 1 | 1 | 1 | 1 | 1 | 1 | 1 | 0 | 0 | 0 | 0 | 0 | 0 | 0 | 0 |
| | Blue (255) | 0 | 0 | 0 | 0 | 0 | 0 | 0 | 0 | 0 | 0 | 0 | 0 | 0 | 0 | 0 | 0 | 1 | 1 | 1 | 1 | 1 | 1 | 1 | 1 |
| | Cyan | 0 | 0 | 0 | 0 | 0 | 0 | 0 | 0 | 1 | 1 | 1 | 1 | 1 | 1 | 1 | 1 | 1 | 1 | 1 | 1 | 1 | 1 | 1 | 1 |
| | Magenta | 1 | 1 | 1 | 1 | 1 | 1 | 1 | 1 | 0 | 0 | 0 | 0 | 0 | 0 | 0 | 0 | 1 | 1 | 1 | 1 | 1 | 1 | 1 | 1 |
| | Yellow | 1 | 1 | 1 | 1 | 1 | 1 | 1 | 1 | 1 | 1 | 1 | 1 | 1 | 1 | 1 | 1 | 0 | 0 | 0 | 0 | 0 | 0 | 0 | 0 |
| | White | 1 | 1 | 1 | 1 | 1 | 1 | 1 | 1 | 1 | 1 | 1 | 1 | 1 | 1 | 1 | 1 | 1 | 1 | 1 | 1 | 1 | 1 | 1 | 1 |
| RED | RED (000) Dark | 0 | 0 | 0 | 0 | 0 | 0 | 0 | 0 | 0 | 0 | 0 | 0 | 0 | 0 | 0 | 0 | 0 | 0 | 0 | 0 | 0 | 0 | 0 | 0 |
| | RED (001) | 0 | 0 | 0 | 0 | 0 | 0 | 0 | 1 | 0 | 0 | 0 | 0 | 0 | 0 | 0 | 0 | 0 | 0 | 0 | 0 | 0 | 0 | 0 | 0 |
| | ... | ... | | | | | | | | ... | | | | | | | | ... | | | | | | | |
| | RED (254) | 1 | 1 | 1 | 1 | 1 | 1 | 1 | 0 | 0 | 0 | 0 | 0 | 0 | 0 | 0 | 0 | 0 | 0 | 0 | 0 | 0 | 0 | 0 | 0 |
| | RED (255) | 1 | 1 | 1 | 1 | 1 | 1 | 1 | 1 | 0 | 0 | 0 | 0 | 0 | 0 | 0 | 0 | 0 | 0 | 0 | 0 | 0 | 0 | 0 | 0 |
| GREEN | GREEN (000) Dark | 0 | 0 | 0 | 0 | 0 | 0 | 0 | 0 | 0 | 0 | 0 | 0 | 0 | 0 | 0 | 0 | 0 | 0 | 0 | 0 | 0 | 0 | 0 | 0 |
| | GREEN (001) | 0 | 0 | 0 | 0 | 0 | 0 | 0 | 0 | 0 | 0 | 0 | 0 | 0 | 0 | 0 | 1 | 0 | 0 | 0 | 0 | 0 | 0 | 0 | 0 |
| | ... | ... | | | | | | | | ... | | | | | | | | ... | | | | | | | |
| | GREEN (254) | 0 | 0 | 0 | 0 | 0 | 0 | 0 | 0 | 1 | 1 | 1 | 1 | 1 | 1 | 1 | 0 | 0 | 0 | 0 | 0 | 0 | 0 | 0 | 0 |
| | GREEN (255) | 0 | 0 | 0 | 0 | 0 | 0 | 0 | 0 | 1 | 1 | 1 | 1 | 1 | 1 | 1 | 1 | 0 | 0 | 0 | 0 | 0 | 0 | 0 | 0 |
| BLUE | BLUE (000) Dark | 0 | 0 | 0 | 0 | 0 | 0 | 0 | 0 | 0 | 0 | 0 | 0 | 0 | 0 | 0 | 0 | 0 | 0 | 0 | 0 | 0 | 0 | 0 | 0 |
| | BLUE (001) | 0 | 0 | 0 | 0 | 0 | 0 | 0 | 0 | 0 | 0 | 0 | 0 | 0 | 0 | 0 | 0 | 0 | 0 | 0 | 0 | 0 | 0 | 0 | 1 |
| | ... | ... | | | | | | | | ... | | | | | | | | ... | | | | | | | |
| | BLUE (254) | 0 | 0 | 0 | 0 | 0 | 0 | 0 | 0 | 0 | 0 | 0 | 0 | 0 | 0 | 0 | 0 | 1 | 1 | 1 | 1 | 1 | 1 | 1 | 0 |
| | BLUE (255) | 0 | 0 | 0 | 0 | 0 | 0 | 0 | 0 | 0 | 0 | 0 | 0 | 0 | 0 | 0 | 0 | 1 | 1 | 1 | 1 | 1 | 1 | 1 | 1 |

Product Specification

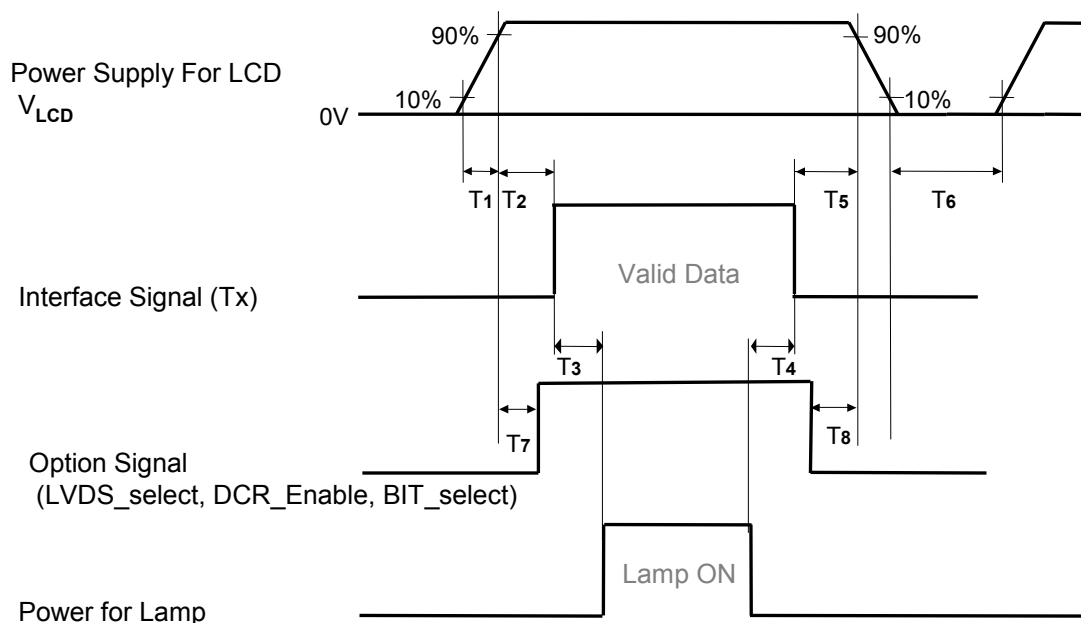
3-6. Power Sequence**3-6-1. LCD Driving circuit****Table 8. POWER SEQUENCE**

| Parameter | Value | | | Unit | Notes |
|-----------|--------------------|-----|-----|------|-------|
| | Min | Typ | Max | | |
| T1 | 0.5 | - | 20 | ms | |
| T2 | 0.5 | - | - | ms | 4 |
| T3 | $3 \times (1/f_V)$ | - | - | ms | 3 |
| T4 | 200 | - | - | ms | 3 |
| T5 | 0 | - | - | ms | |
| T6 | 2.0 | - | - | s | 5 |
| T7 | 0 | - | T2 | ms | 4 |
| T8 | 0 | - | - | ms | 4 |

- Note :
1. Please avoid floating state of interface signal at invalid period.
 2. When the interface signal is invalid, be sure to pull down the power supply V_{LCD} to 0V.
 3. The T3/T4 is recommended value, the case when failed to meet a minimum specification, abnormal display would be shown. There is no reliability problem.
 4. If the on time of signals (Interface signal and Option signals) precedes the on time of Power (V_{LCD}), check the LCD logic Power (V_{CC}) is under 0.8V, otherwise it will be happened abnormal display.
 5. T6 should be measured after the Module has been fully discharged between power off and on period.

Product Specification

3-6-2. Sequence for Inverter

Power Supply For Inverter

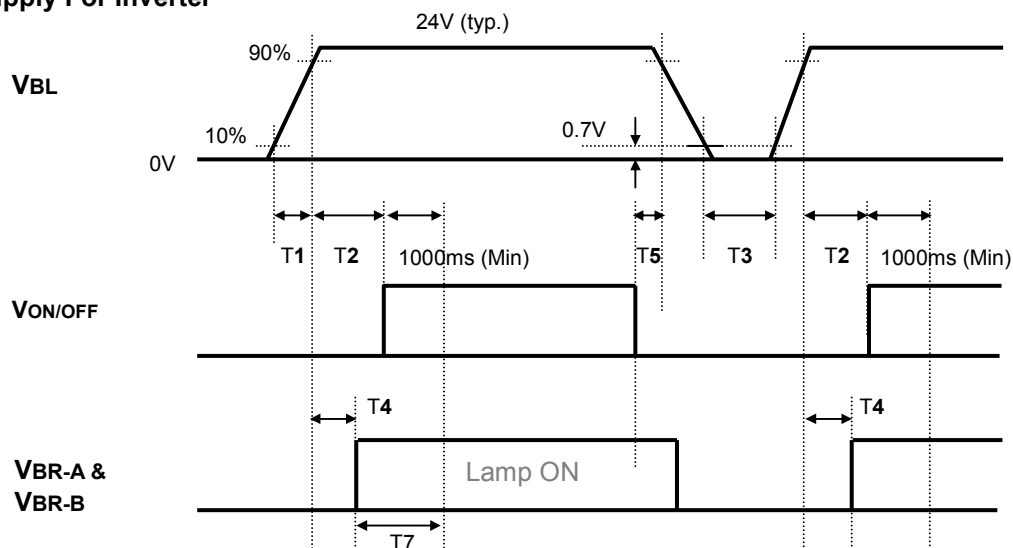

3-6-3. Deep condition for Inverter

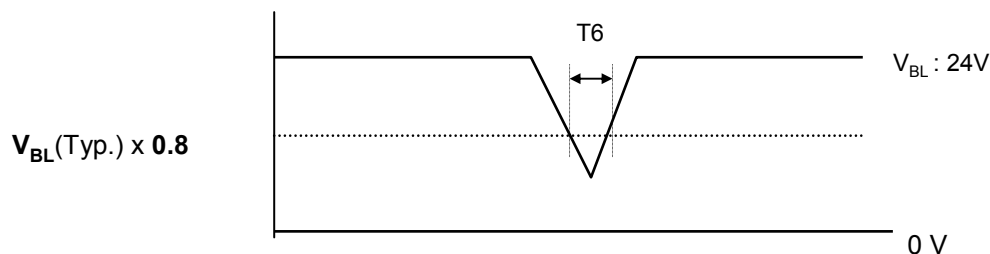

Table 9. Power Sequence for Inverter

| Parameter | Values | | | Units | Remarks |
|-----------|--------|-----|-----|-------|--------------------------|
| | Min | Typ | Max | | |
| T1 | 20 | - | - | ms | 1 |
| T2 | 500 | - | - | ms | |
| T3 | 200 | - | - | ms | |
| T4 | 0 | - | - | ms | 2 |
| T5 | 10 | - | - | ms | |
| T6 | - | - | 10 | ms | $V_{BL}(Typ) \times 0.8$ |
| T7 | 1000 | - | - | ms | 3 |

Notes : 1. T1 describes rising time of 0V to 24V and this parameter does not applied at restarting time.

2. T4(max) is less than T2.

3. In T7 section, VBR-B is recommended 3.3V.

Product Specification

4. Optical Specification

Optical characteristics are determined after the unit has been 'ON' and stable in a dark environment at $25 \pm 2^\circ\text{C}$. The values are specified at an approximate distance 50cm from the LCD surface at a viewing angle of Φ and θ equal to 0° .

It is presented additional information concerning the measurement equipment and method in FIG. 1.

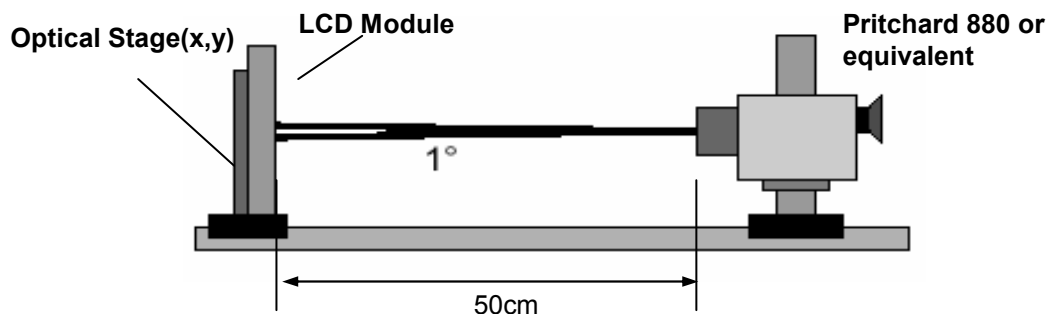

FIG. 1 Optical Characteristic Measurement Equipment and Method

$T_a = 25 \pm 2^\circ\text{C}$, $V_{LCD} = 12.0\text{V}$, $f_v = 60\text{Hz}$, $D_{clk} = 72.4\text{MHz}$,
 $V_{BR-A} = 1.65\text{V}$, $V_{BR-B} = 3.3\text{V}$ (Except DCR Function)

Table 10. OPTICAL CHARACTERISTICS

| Parameter | Symbol | Value | | | Unit | Note | |
|--------------------------------|-----------------------------------|------------|--------------|-------|-------------------|--------|---|
| | | Min | Typ | Max | | | |
| Contrast Ratio | CR | 600 | 800 | | | 1 | |
| Surface Luminance, white | L_{WH} | 400 | 500 | | cd/m ² | 2 | |
| Luminance Variation | δ_{WHITE} 5P | | | 1.3 | | 3 | |
| Response Time | Gray-to-Gray | G to G | - | 9 | 14 | ms | 4 |
| Color Coordinates [CIE1931] | RED | Rx | Typ -0.03 | TBD | Typ +0.03 | | |
| | | Ry | | TBD | | | |
| | GREEN | Gx | | TBD | | | |
| | | Gy | | TBD | | | |
| | BLUE | Bx | | TBD | | | |
| | | By | | TBD | | | |
| | WHITE | Wx | | 0.279 | | | |
| Wy | | 0.292 | | | | | |
| Viewing Angle (CR>10) | | | | | | | |
| | x axis, right($\phi=0^\circ$) | θ_r | 89 | - | - | degree | 5 |
| | x axis, left ($\phi=180^\circ$) | θ_l | 89 | - | - | | |
| | y axis, up ($\phi=90^\circ$) | θ_u | 89 | - | - | | |
| | y axis, down ($\phi=270^\circ$) | θ_d | 89 | - | - | | |
| Gray Scale | | | - | 2.2 | - | | 6 |

Product Specification

Notes :1. Contrast Ratio(CR) is defined mathematically as :

CR(Contrast Ratio) = Maximum CR_n (n=1, 2, 3, 4, 5)

$$CR_n = \frac{\text{Surface Luminance at position n with all white pixels}}{\text{Surface Luminance at position n with all black pixels}}$$

n = the Position number(1, 2, 3, 4, 5). For more information, see FIG 2.

2. Surface luminance are determined after the unit has been 'ON' and 30min after lighting the backlight in a dark environment at $25 \pm 2^\circ\text{C}$. Surface luminance is the luminance value at center 1-point across the LCD surface 50cm from the surface with all pixels displaying white.

For more information see the FIG. 2.

3. The variation in surface luminance, δ WHITE is defined as :

$$\delta \text{ WHITE}(5P) = \text{Maximum}(L_{on1}, L_{on2}, L_{on3}, L_{on4}, L_{on5}) / \text{Minimum}(L_{on1}, L_{on2}, L_{on3}, L_{on4}, L_{on5})$$

Where L_{on1} to L_{on5} are the luminance with all pixels displaying white at 5 locations .

For more information, see the FIG. 2.

4. Response time is the time required for the display to transition from G(N) to G(M) (Rise Time, Tr_R) and from G(M) to G(N) (Decay Time, Tr_D). For additional information see the FIG. 3. (N<M)

5. Viewing angle is the angle at which the contrast ratio is greater than 10. The angles are determined for the horizontal or x axis and the vertical or y axis with respect to the z axis which is normal to the LCD module surface. For more information, see the FIG. 4.

6. Gray scale specification

Gamma Value is approximately 2.2. For more information, see the Table 11.

Table 11. GRAY SCALE SPECIFICATION

| Gray Level | Luminance [%] (Typ) |
|------------|---------------------|
| L0 | 0.12 |
| L15 | 0.29 |
| L31 | 1.10 |
| L47 | 2.69 |
| L63 | 5.12 |
| L79 | 8.67 |
| L95 | 13.3 |
| L111 | 18.1 |
| L127 | 23.7 |
| L143 | 29.9 |
| L159 | 36.9 |
| L175 | 45.6 |
| L191 | 55.4 |
| L207 | 65.2 |
| L223 | 76.2 |
| L239 | 85.9 |
| L255 | 100 |

Product Specification

Measuring point for surface luminance & measuring point for luminance variation

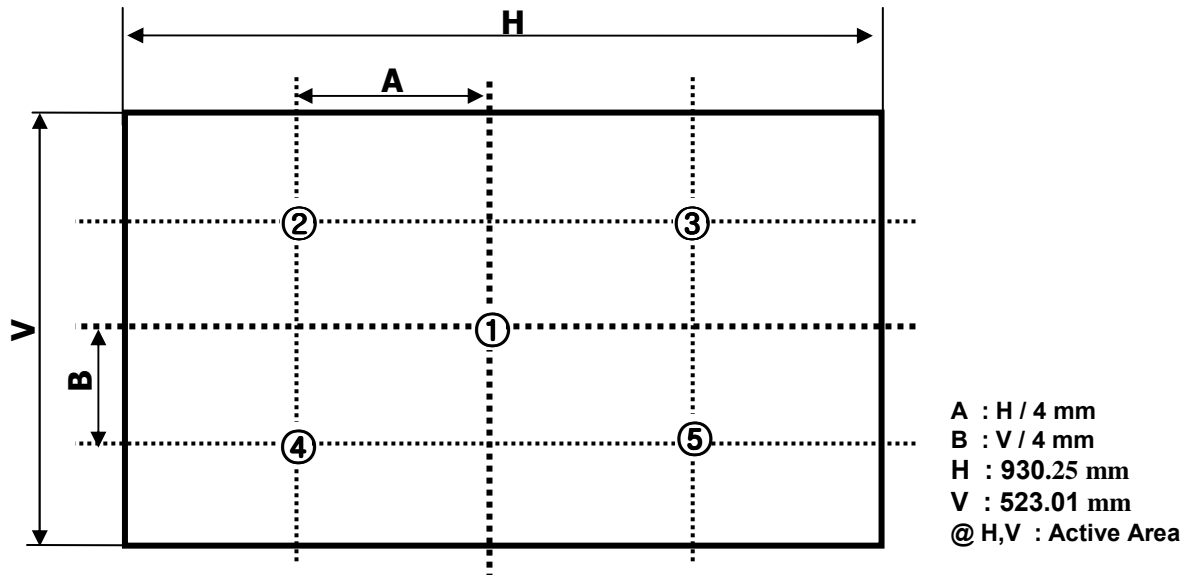

FIG. 2 5 Points for Luminance Measure

Response time is defined as the following figure and shall be measured by switching the input signal for "Gray(N)" and "Gray(M)".

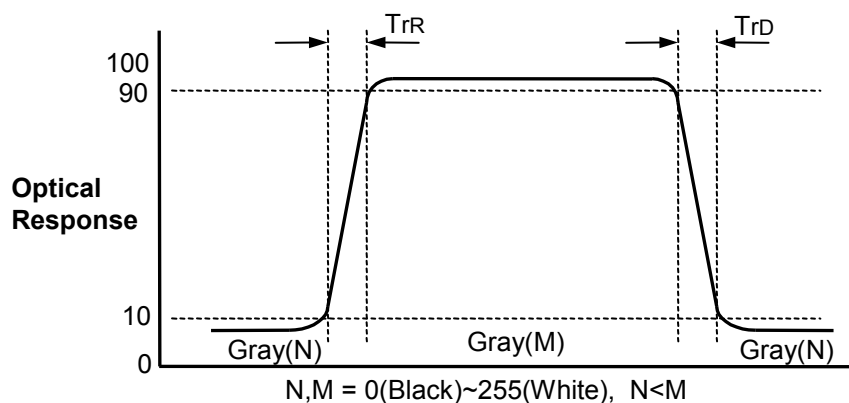

FIG.3 Response Time

Product Specification

Dimension of viewing angle range

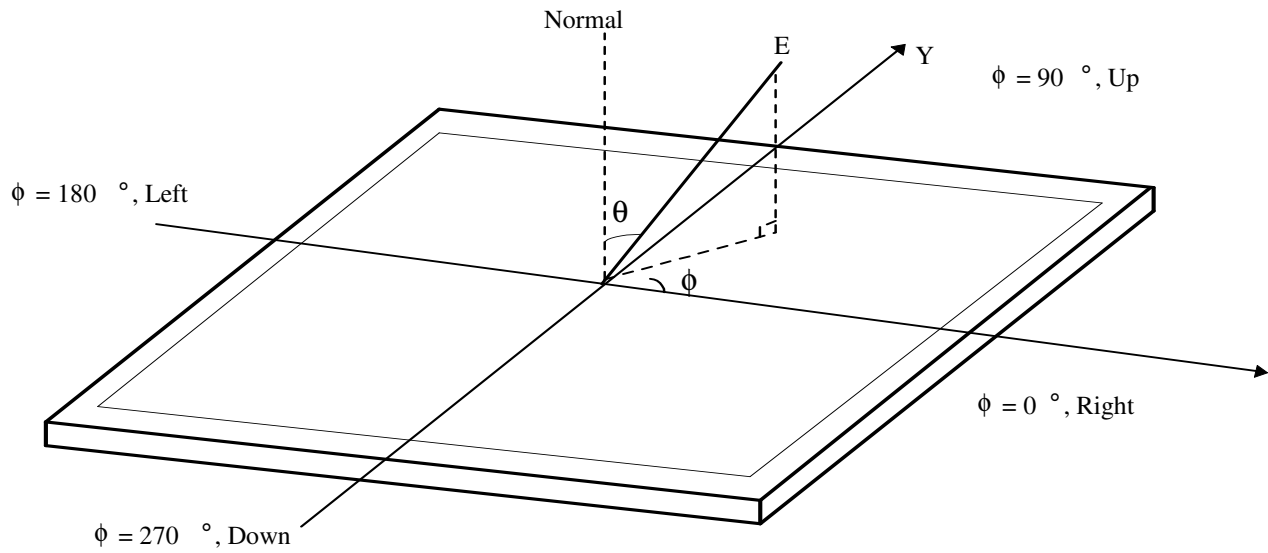

FIG.4 Viewing Angle

Product Specification

5. Mechanical Characteristics

Table 12 provides general mechanical characteristics.

Table 12. MECHANICAL CHARACTERISTICS

| Item | Value | |
|---------------------|---------------------------------|-----------|
| Outline Dimension | Horizontal | 983.0 mm |
| | Vertical | 576.0 mm |
| | Depth | 51.0 mm |
| Bezel Area | Horizontal | 939.0 mm |
| | Vertical | 531.0 mm |
| Active Display Area | Horizontal | 930.25 mm |
| | Vertical | 523.01 mm |
| Weight | 10.5 Kg (Typ.) , 11.0 Kg (Max.) | |

Note : 1.Please refer to a mechanic drawing in terms of tolerance at the next page.

Product Specification

<FRONT VIEW>

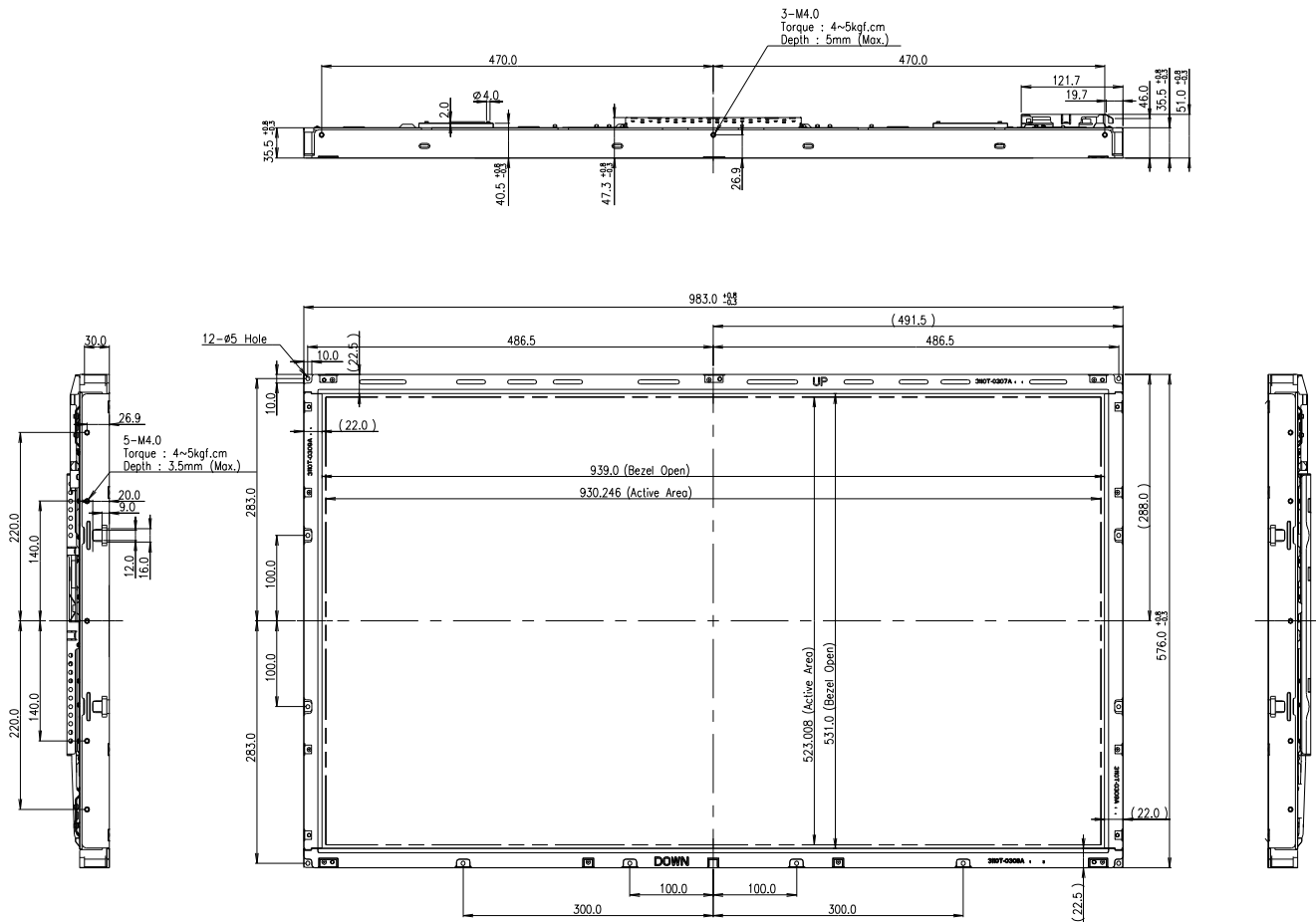

SCALE 1/4

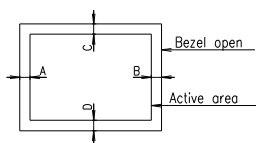
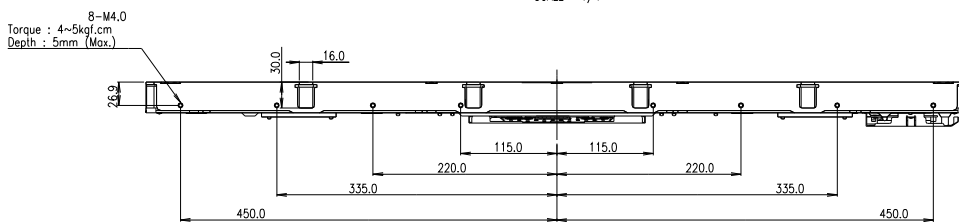

- NOTES
1. Unspecified tolerances are to be ± 1.0 mm.
 2. Tilt and partial disposition tolerance of display area are as following.
 - (1) X-Direction : $IA-BI \leq 1.5$ mm
 - (2) Y-Direction : $IC-DI \leq 1.5$ mm

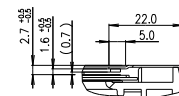

SECTION A-A
SCALE 1/1

Product Specification

<REAR VIEW>

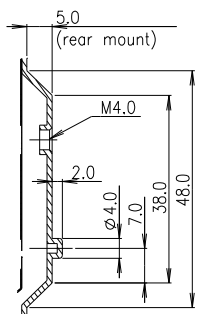
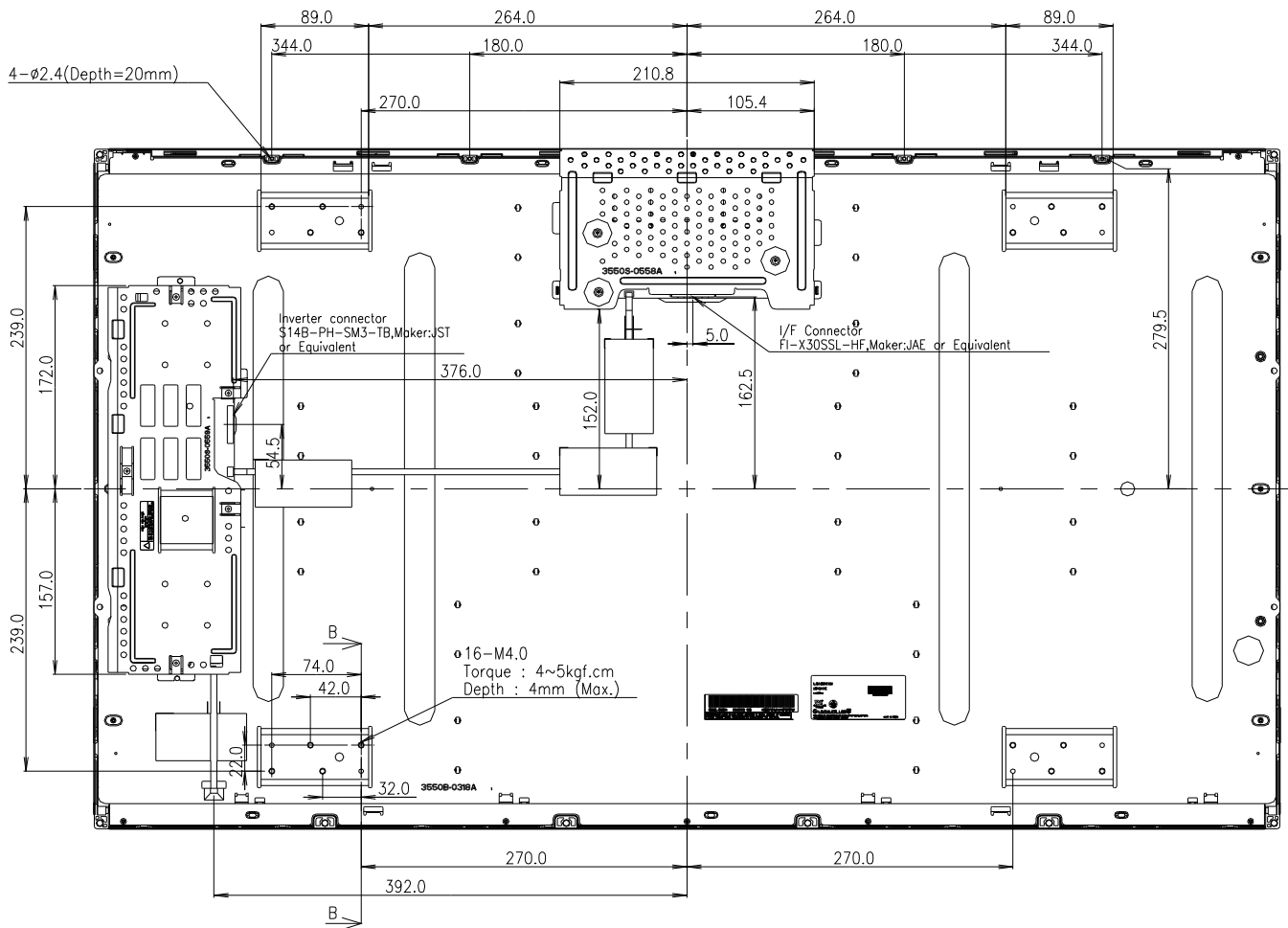

SECTION B-B
SCALE 1/1

Product Specification

6. Reliability**Table 13. ENVIRONMENT TEST CONDITION**

| No. | Test Item | Condition |
|-----|--|--|
| 1 | High temperature storage test | Ta= 60°C 240h |
| 2 | Low temperature storage test | Ta= -20°C 240h |
| 3 | High temperature operation test | Ta= 50°C 50%RH 240h |
| 4 | Low temperature operation test | Ta= 0°C 240h |
| 5 | Vibration test (operating) | Wave form : random Vibration level : 1.0Grms Bandwidth : 10-300Hz Duration : X,Y,Z, 30 min One time each direction |
| 6 | Shock test (operating) | Shock level : 50Grms Waveform : half sine wave, 11ms Direction : ±X, ±Y, ±Z One time each direction |
| 7 | Humidity condition Operation | Ta= 40 °C ,90%RH |
| 8 | Altitude operating storage / shipment | 0 - 14,000 feet(4267.2m) 0 - 40,000 feet(12192m) |

Note : Before and after Reliability test, LCM should be operated with normal function.

7. International Standards

7-1. Safety

- a) UL 60065, 7th Edition, dated June 30, 2003, Underwriters Laboratories, Inc., Standard for Audio, Video and Similar Electronic Apparatus.
- b) CAN/CSA C22.2, No. 60065:03, Canadian Standards Association, Standard for Audio, Video and Similar Electronic Apparatus.
- c) IEC60065:2001, 7th Edition CB-scheme and EN 60065:2002, Safety requirements for Audio, Video and Similar Electronic Apparatus..

7-2. EMC

- a) ANSI C63.4 "Methods of Measurement of Radio-Noise Emissions from Low-Voltage Electrical and Electrical Equipment in the Range of 9kHz to 40GHz. "American National Standards Institute(ANSI), 1992
- b) CISPR13 "Limits and Methods of Measurement of Radio interference characteristics of Sound and Television broadcast receivers and associated equipment"
CISPR22 "Limits and Methods of Measurement of Radio interference characteristics of Information Technology Equipment" International Special Committee on Radio Interference.
- c) EN55013 "Limits and Methods of Measurement of Radio interference characteristics of Sound and Television broadcast receivers and associated equipment"
EN55022 "Limits and Methods of Measurement of Radio interference characteristics of Information Technology Equipment" European Committee for Electro Technical Standardization.(CENELEC), 1988(Including A1:2000)

Product Specification

8. Packing

8-1. Designation of Lot Mark

a) Lot Mark

| | | | | | | | | | | | | |
|---|---|---|---|---|---|---|---|---|---|---|---|---|
| A | B | C | D | E | F | G | H | I | J | K | L | M |
|---|---|---|---|---|---|---|---|---|---|---|---|---|

A,B,C : SIZE(INCH)

E : MONTH

D : YEAR

F ~ M : SERIAL NO.

Note

1. YEAR

| | | | | | | | | | | |
|------|------|------|------|------|------|------|------|------|------|------|
| Year | 2001 | 2002 | 2003 | 2004 | 2005 | 2006 | 2007 | 2008 | 2009 | 2010 |
| Mark | 1 | 2 | 3 | 4 | 5 | 6 | 7 | 8 | 9 | 0 |

2. MONTH

| | | | | | | | | | | | | |
|-------|-----|-----|-----|-----|-----|-----|-----|-----|-----|-----|-----|-----|
| Month | Jan | Feb | Mar | Apr | May | Jun | Jul | Aug | Sep | Oct | Nov | Dec |
| Mark | 1 | 2 | 3 | 4 | 5 | 6 | 7 | 8 | 9 | A | B | C |

b) Location of Lot Mark

Serial No. is printed on the label. The label is attached to the backside of the LCD module.
This is subject to change without prior notice.

8-2. Packing Form

a) Package quantity in one box : 12 pcs

b) Box Size :1140 mm(L) X 990 mm(W) X 820 mm(H)

Product Specification

9. Precautions

Please pay attention to the followings when you use this TFT LCD module.

9-1. Mounting Precautions

- (1) You must mount a module using specified mounting holes (Details refer to the drawings).
- (2) You should consider the mounting structure so that uneven force (ex. Twisted stress) is not applied to the module. And the case on which a module is mounted should have sufficient strength so that external force is not transmitted directly to the module.
- (3) Please attach the surface transparent protective plate to the surface in order to protect the polarizer. Transparent protective plate should have sufficient strength in order to resist external force.
- (4) You should adopt radiation structure to satisfy the temperature specification.
- (5) Acetic acid type and chlorine type materials for the cover case are not desirable because the former generates corrosive gas of attacking the polarizer at high temperature and the latter causes circuit break by electro-chemical reaction.
- (6) Do not touch, push or rub the exposed polarizers with glass, tweezers or anything harder than HB pencil lead. And please do not rub with dust clothes with chemical treatment. Do not touch the surface of polarizer for bare hand or greasy cloth. (Some cosmetics are detrimental to the polarizer.)
- (7) When the surface becomes dusty, please wipe gently with absorbent cotton or other soft materials like chamois soaks with petroleum benzine. Normal-hexane is recommended for cleaning the adhesives used to attach front / rear polarizers. Do not use acetone, toluene and alcohol because they cause chemical damage to the polarizer. There is no problem of Panel crack under 5kgf / ϕ 10mm
- (8) Wipe off saliva or water drops as soon as possible. Their long time contact with polarizer causes deformations and color fading.
- (9) Do not open the case because inside circuits do not have sufficient strength.

9-2. Operating Precautions

- (1) The spike noise causes the mis-operation of circuits. It should be lower than following voltage :
V=± 200mV(Over and under shoot voltage)
- (2) Response time depends on the temperature. (In lower temperature, it becomes longer.)
- (3) Brightness depends on the temperature. (In lower temperature, it becomes lower.)
And in lower temperature, response time(required time that brightness is stable after turned on) becomes longer
- (4) Be careful for condensation at sudden temperature change. Condensation makes damage to polarizer or electrical contacted parts. And after fading condensation, smear or spot will occur.
- (5) When fixed patterns are displayed for a long time, remnant image is likely to occur.
- (6) Module has high frequency circuits. Sufficient suppression to the electromagnetic interference shall be done by system manufacturers. Grounding and shielding methods may be important to minimize the interference.
- (7) Please do not give any mechanical and/or acoustical impact to LCM. Otherwise, LCM can't be operated its full characteristics perfectly.
- (8) A screw which is fastened up the steels should be a machine screw.
(if not, it can cause conductive particles and deal LCM a fatal blow)
- (9) Please do not set LCD on its edge.
- (10) It is recommended to avoid the signal cable and conductive material over the inverter transformer for it can cause the abnormal display and temperature rising.
- (11) Partial darkness may happen during 3~5 minutes when LCM is operated initially in condition that luminance is under 40% at low temperature (under 5℃). This phenomenon which disappears naturally after 3~5 minutes is not a problem about reliability but LCD characteristic

9-3. Electrostatic Discharge Control

Since a module is composed of electronic circuits, it is not strong to electrostatic discharge. Make certain that treatment persons are connected to ground through wrist band etc. And don't touch interface pin directly.

9-4. Precautions for Strong Light Exposure

Strong light exposure causes degradation of polarizer and color filter.

9-5. Storage

When storing modules as spares for a long time, the following precautions are necessary.

- (1) Store them in a dark place. Do not expose the module to sunlight or fluorescent light. Keep the temperature between 5°C and 35°C at normal humidity.
- (2) The polarizer surface should not come in contact with any other object.
It is recommended that they be stored in the container in which they were shipped.

9-6. Handling Precautions for Protection Film

- (1) The protection film is attached to the bezel with a small masking tape.
When the protection film is peeled off, static electricity is generated between the film and polarizer.
This should be peeled off slowly and carefully by people who are electrically grounded and with well ion-blown equipment or in such a condition, etc.
- (2) When the module with protection film attached is stored for a long time, sometimes there remains a very small amount of glue still on the bezel after the protection film is peeled off.
- (3) You can remove the glue easily. When the glue remains on the bezel surface or its vestige is recognized, please wipe them off with absorbent cotton waste or other soft material like chamois soaked with normal-hexane.

9-7. Appropriate Condition for Public Display

- Generally large-sized LCD modules are designed for consumer applications (TV).

Accordingly, a long-term display like in Public Display (PD) application, can cause uneven display including image sticking. To optimize module's lifetime and function, several operating usages are required.

1. Normal operating condition

- Temperature: 0 ~ 40°C
- Operating Ambient Humidity : 10 ~ 90 %
- Display pattern: dynamic pattern (Real display)

Note) Long-term static display can cause image sticking.

2. Operating usages under abnormal condition1

a. Ambient condition

- Well-ventilated place is recommended to set up PD system.

b. Power and screen save

- Periodical power-off or screen save is needed after long-term display.

Product Specification

3. Operating usages to protect against image sticking due to long-term static display
 - a. Suitable operating time: under 18 hours a day.
 - b. Static information display recommended to use with moving image.
 - Cycling display between 5 minutes' information(static) display and 10 seconds' moving image.
 - c. Background and character (image) color change
 - Use different colors for background and character, respectively.
 - Change colors themselves periodically.
 - d. Avoid combination of background and character with large different luminance.
 - 1) Abnormal condition just means conditions except normal condition.
 - 2) Black image or moving image is strongly recommended as a screen save.
4. Lifetime in this spec. is guaranteed only when PD is used according to operating usages.

APPENDIX-I-1

■ Required signal assignment for Flat Link (DS90C385) Transmitter(Pin9="L")

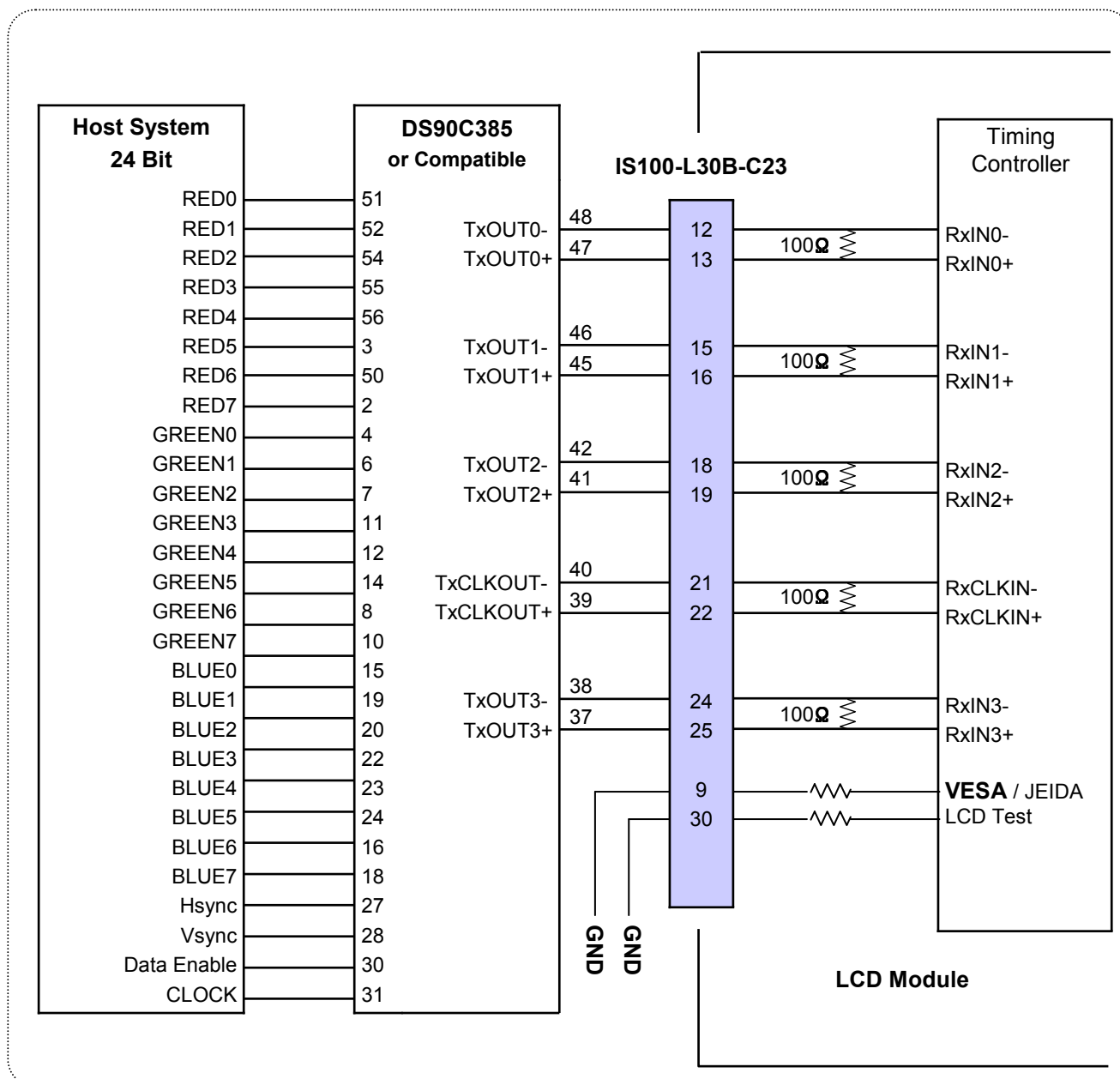

Notes:

1. The LCD module uses a 100 Ohm(Ω) resistor between positive and negative lines of each receiver input.
2. Refer to LVDS transmitter data sheet for detail descriptions. (THC63LVD823 or Compatible)
3. '7' means MSB and '0' means LSB at R,G,B pixel data.

APPENDIX-I-2

■ Required signal assignment for Flat Link (DS90C385) Transmitter(Pin9="H")

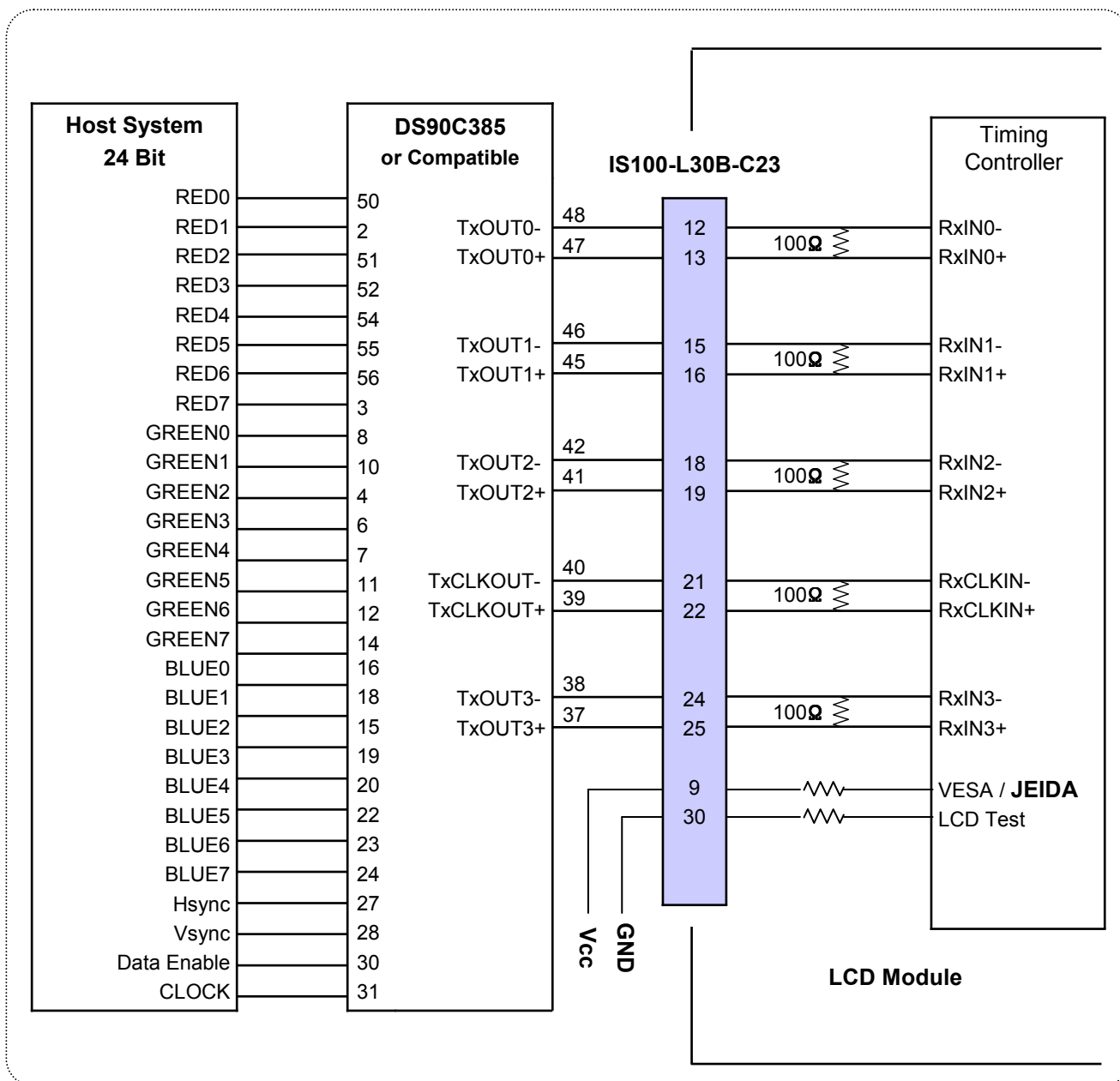

Notes:

1. The LCD module uses a 100 Ohm(Ω) resistor between positive and negative lines of each receiver input.
2. Refer to LVDS transmitter data sheet for detail descriptions. (THC63LVD823 or Compatible)
3. '7' means MSB and '0' means LSB at R,G,B pixel data.

Product Specification

APPENDIX-II

■ LD420WXN-SAA1 – Pallet Ass'y

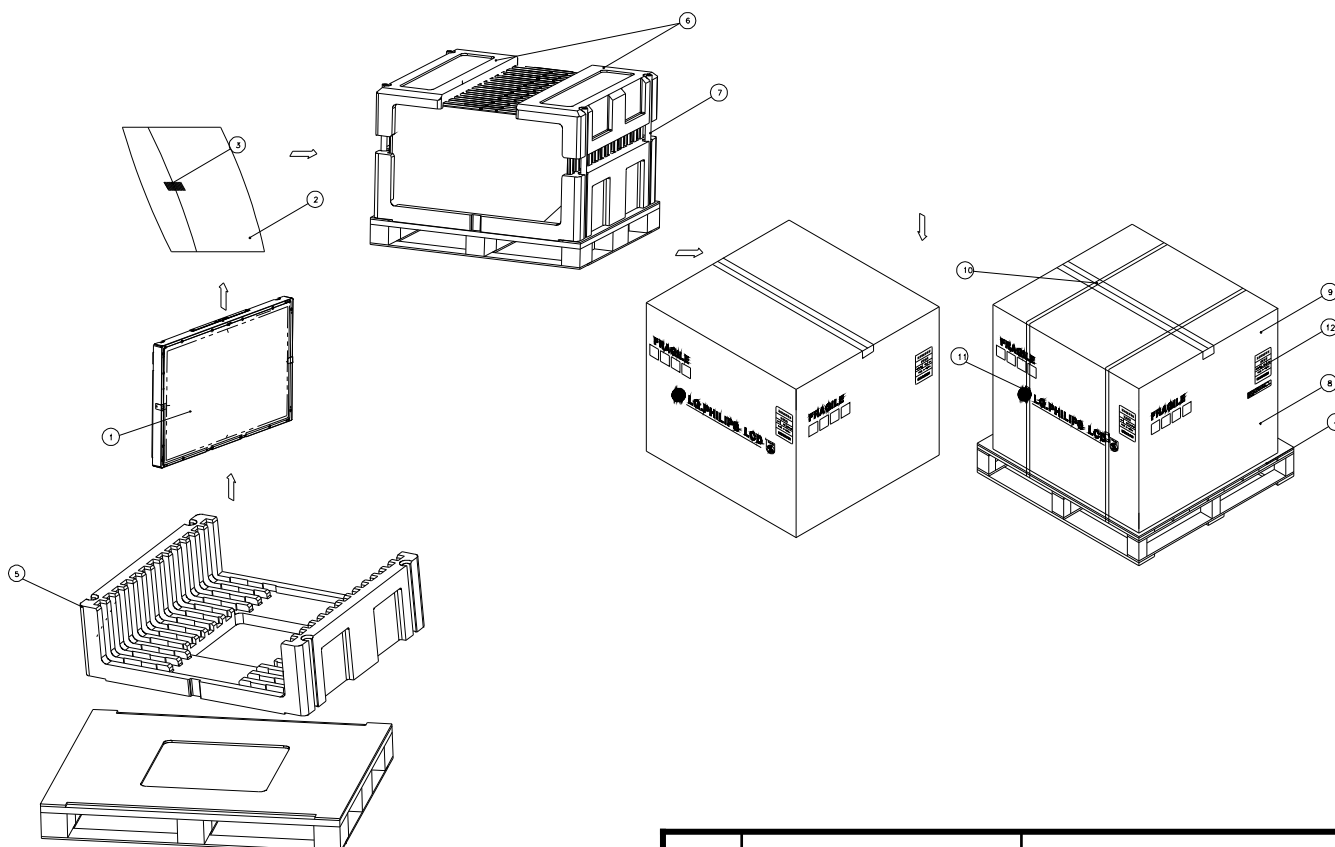

| NO. | DESCRIPTION | MATERIAL |
|-----|----------------|----------------------|
| 1 | LCD Module | |
| 2 | BAG | 42INCH |
| 3 | TAPE | MASKING 20MMX50M |
| 4 | PALLET | PAPER 1140X990X130MM |
| 5 | PACKING,BOTTOM | EPS |
| 6 | PACKING, TOP | EPS |
| 7 | ANGLE, POST | PAPER |
| 8 | ANGLE, PACKING | PAPER |
| 9 | BAND, CLIP | STEEL |
| 10 | BAND | PP |
| 11 | LABEL | YUPO 80G 100X100 |

Product Specification

APPENDIX-III-1

■ LCM Label

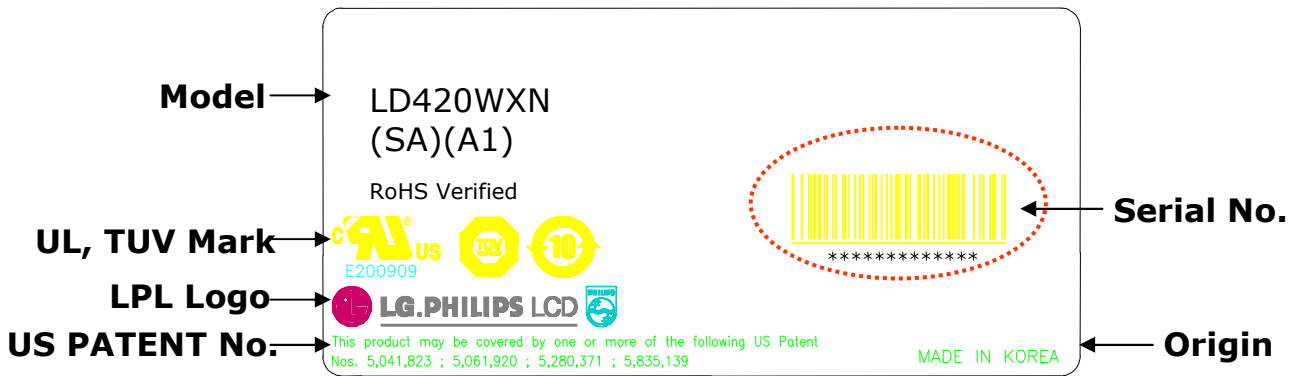

■ Serial No. (See CAS 24 page for more information)

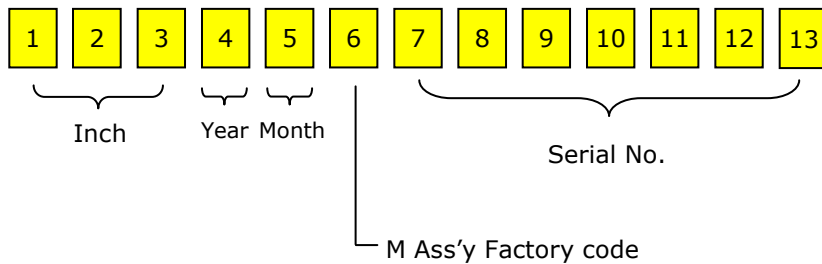

APPENDIX- III-2

■ Pallet Label

| | |
|---|---------------|
| LD420WXN | |
| SAA1 | |
| 12 PCS | 001/01-01 |
| REMARK | |
| MADE IN KOREA | RoHS Verified |
|  ***** ** | |