

TFT-Display Datenblatt

Modell PD035VX3

Kurzdaten

Hersteller	E INK / PrimeView
Diagonale	3,5" / 8,9cm
Format	4:3
Auflösung	640x480
Backlight	LED/200cd/m ²
Interface	LVDS
Touchscreen	ja
Temperatur	-20...+60°C (Betrieb)

Version : 3.0



Inselkammerstr. 10
82008 Unterhaching
Tel: +49 89 614 503 40
www.hy-line.de/computer

TECHNICAL SPECIFICATION

MODEL NO : PD035VX3

The content of this information is subject to be changed without notice.
Please contact PVI or its agent for further information.

Customer's Confirmation

Customer _____

Date _____

By _____

PVI's Confirmation

Confirmed By _____



Prepared By _____



PRIME VIEW INTERNATIONAL CO.,LTD.

3,LI SHIN RD. 1,SCIENCE-BASED INDUSTRIAL

PARK,HSINCHU,TAIWAN,R.O.C.

Http://www.pvi.com.tw

Date :Dec. 21 2007

This technical specification is subject to change without notice.
Please return 1 copy with your signature on this page for approval.

Revision History

Rev.	Issued Date	Revised Contents
0.1	Apr. 12 , 2005	Preliminary
1.0	July.15 , 2005	Release version
2.0	Nov.30, 2006	Page 19 13. Optical Characteristics Brightness from typ.=210(cd/m ²),min.=180(cd/m ²) Modify to typ.=200(cd/m ²),min.=170(cd/m ²)
3.0	Dec.25,2007	Modify Page 25: 16.Delete carton and change Packing

TECHNICAL SPECIFICATION**CONTENTS**

<i>NO.</i>	<i>ITEM</i>	<i>PAGE</i>
-	Cover	1
-	Revision History	2
-	Contents	3
1	Application	4
2	Features	4
3	Mechanical Specifications	4
4	Mechanical Drawing of TFT-LCD module	5
5	Input / Output Terminals	6
6	Absolute Maximum Ratings	9
7	Electrical Characteristics	10
8	Pixel Arrangement	10
9	Display Color and Gray Scale Reference	12
10	Block Diagram	13
11	Interface Timing	14
12	Power On Sequence	19
13	Optical Characteristics	19
14	Handling Cautions	20
15	Reliability Test	24
16	Packing	25
-	Appendix	26

1. Application

This data sheet applies to a color TFT LCD module, PD035VX3.

The application of panel are projector and other media application which require high quality flat panel display.

2. Features

- . Amorphous silicon TFT LCD panel with LED B/L.
- . Module with resistive type touch panel .
- . Pixel in stripe configuration
- . Display Colors : 262,144 colors
- . TTL transmission interface

3. Mechanical Specifications

Parameter	Specifications	Unit
Screen Size	3.5 (diagonal)	inch
Display Format	640×(R, G, B)×480	dot
Display Colors	262,144	
Active Area	72.0 (H)×52.56 (V)	mm
Pixel Pitch	0.1125 (H)×0.1095 (V)	mm
Pixel Configuration	Stripe	
Outline Dimension	84.03 (W)×65.24 (H)×4.55 (D) (Typ.)	mm
Weight	52±5	g
Surface treatment	AG	
Display Mode	Normally white	
Surface treatment of Touch Panel	3H	
Backlight	6-LED	
Gray scale inversion direction	6 o'clock [Note:14-2]	

4.Mechanical Drawing of TFT-LCD Module

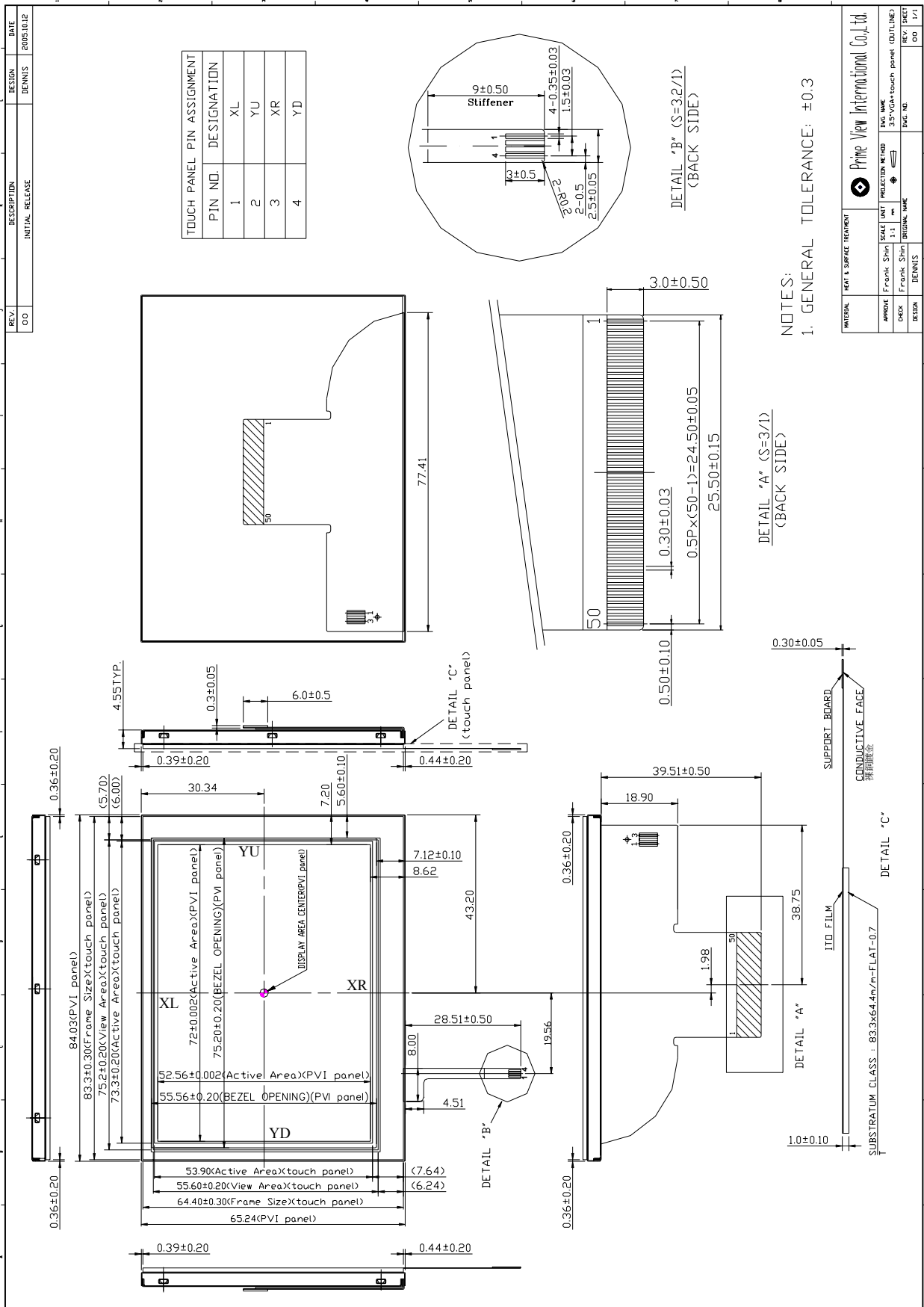

The information contained herein is the exclusive property of Prime View International Co., Ltd. and shall not be distributed, reproduced, or disclosed in whole or in part without prior written permission of Prime View International Co., Ltd.

5.Input / Output Terminals

TFT-LCD Panel Driving

Pin No.	Symbol	I/O	Function	Remark
1	DIO1	I/O	Horizontal Start Pulse Signal Input or Output 1	Note5-3
2	VSS2	I	Ground	
3	VDD1	I	Power Supply	
4	CLK	I	Horizontal Shift Clock	
5	R/L	I	Left/Right Selection	Note 5-3
6	R0	I	Red Data (LSB)	
7	R1	I	Red Data	
8	R2	I	Red Data	
9	R3	I	Red Data	
10	R4	I	Red Data	
11	R5	I	Red Data (MSB)	
12	VSS2	I	Ground	
13	G0	I	Green Data (LSB)	
14	G1	I	Green Data	
15	G2	I	Green Data	
16	G3	I	Green Data	
17	G4	I	Green Data	
18	G5	I	Green Data (MSB)	
19	B0	I	Blue Data (LSB)	
20	B1	I	Blue Data	
21	B2	I	Blue Data	
22	B3	I	Blue Data	
23	B4	I	Blue Data	
24	B5	I	Blue Data (MSB)	
25	LD	I	Load output signal	Note5-7
26	REV	I	Data invert control	Note5-8
27	POL	I	Polarity selection	Note5-9
28	DIO2	I/O	Horizontal Start Pulse Signal Input or Output	Note5-3
29	VSS2	I	Ground	
30	V3	I	Gamma Voltage 3	Note5-10
31	V5	I	Gamma Voltage 5	Note5-10
32	V7	I	Gamma Voltage 7	Note5-10
33	V8	I	Gamma Voltage 8	Note5-10
34	V10	I	Gamma Voltage 10	Note5-10
35	V12	I	Gamma Voltage 12	Note5-10
36	VSS2	I	Ground	
37	VDD2	I	Voltage for analog circuit	Note5-10
38	VCOM	I	Common Voltage	
39	OE	I	Output Enable	Note5-5
40	U/D	I	Up/Down Selection	Note5-6
41	CKV	I	Vertical Shift Clock	Note5-4
42	STVU	I/O	Vertical Shift Pulse Signal Input or Output	Note5-6
43	STVD	I/O	Vertical Shift Pulse Signal Input or Output	Note5-6
44	VGG	I	Gate On Voltage	Note5-1
45	VSS1	I	Ground	
46	VCC	I	Voltage for logic circuit	
47	VEE	I	Gate Off Voltage	Note5-2
48	VLED	-	Supply voltage for LED backlight	Note5-11
49	GLED2	-	Ground for LED backlight	
50	GLED1	-	Ground for LED backlight	

Note 5-1 Gate on voltage, $V_{GG} = +17V$.

Note 5-2: Gate off voltage, $V_{EE} = -10V$.

Note 5-3: Select left or right shift

R/L	DIO1	DIO2	Shift
1	Input	Hi-Z	Left to right
0	Hi-Z	Input	Right to left

Note 5-4: Gate driver shift clock

Note 5-5: When OE is connected to high “1”, the driver outputs are disabled (Gate output = V_{EE}).
Under this condition, the operation of registers will not be affected.

Note 5-6: Select up or down shift

U/D	STVU	STVD	Shift
1	Hi-Z	Input	Down to Up
0	Input	Hi-Z	Up to Down

Note 5-7 Latch the polarity of outputs and switch the new data to outputs

At the rising edge (LD), latch the “POL” signal to control the polarity of the outputs.

Note 5-8 Control whether the Data R0~G5 are inverted or not. (PVI suggests connecting to GND)

When “REV=1”, these data will be inverted.

EX: “00”→”3F”, “07”→”38”, “15”→”2A”

Note 5-9: Polarity selector for dot-inversion control. Available at the rising edge of LD.

When POL=1: Even outputs range from V1~V7, and Odd outputs range from V8~V14;

When POL=0: Even outputs range from V8~V14, and Odd outputs range from V1~V7.

Note 5-10

Typical Application Circuit

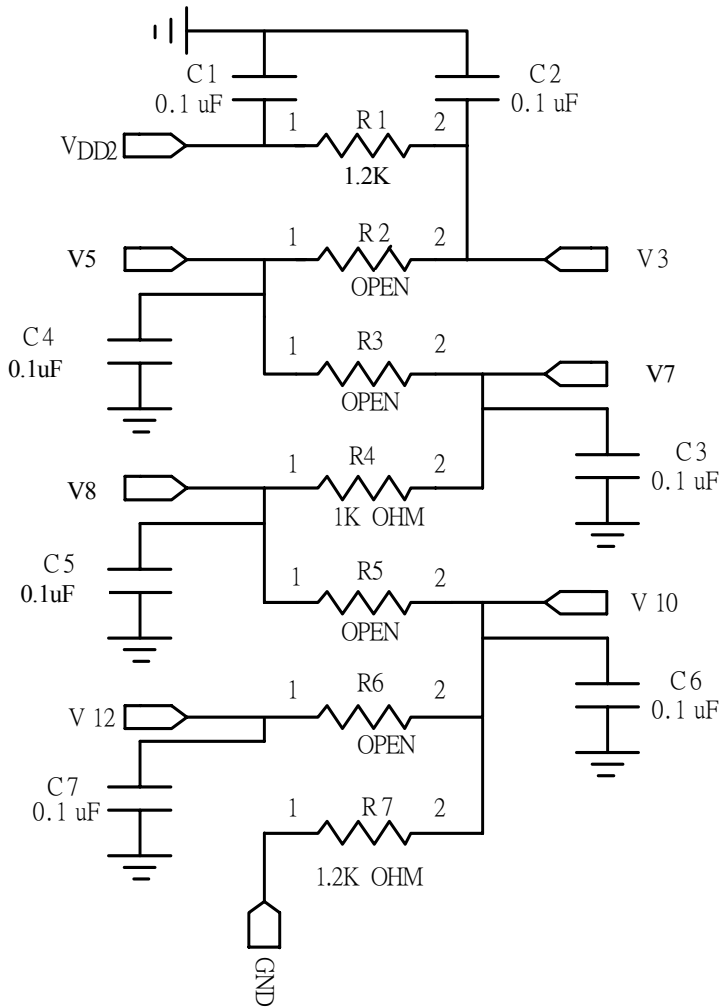

Note 5-11: I_{LED} TYP.=20mA.

6.Touch Panel Characteristics

6.1) Pin assignment:

Pin	Symbol	Function	Remark
1	XL	Upper electrode X (Left side)	
2	YU	Lower electrode (Upper side)	
3	XR	Upper electrode X (Right side)	
4	YD	Lower electrode (Down side)	

6.2) Electrical Performance:

Parameters	Symbol	MIN.	Typ.	MAX.	Unit	Remark
Terminal Resistance	X	100	-	900	Ω	
	Y	100	-	900	Ω	
Input Voltage	V _T	-	5.0	7.0	V	
Linearity(X ,Y direction)	-	-	-	±1.5	%	
Insulation Impedance	-	20	-	-	MΩ	DC 25V
Response Time	-	-	-	5	ms	
Operation Force	-	-	-	35	g	Note 6-1

Note 6-1 Input through 0.8R stylus or finger.

6.3) Durability Performance

1. Hitting Durability:

At least 1,000,000 times with R8.0mm silicon rubber, 200g , 3times/sec .

2. Sliding Durability:

At least 100,000 times with R0.8mm polyacetal stylus , 200g , 60mm/sec.

7.Absolute Maximum Ratings:

$V_{SS1}=V_{SS2}=GND=0V, T_a=25^{\circ}C$

Parameters	Symbol	MIN.	MAX.	Unit	Remark
Supply Voltage	V_{DD1}	-0.5	5.0	V	
	V_{CC}	-0.3	5.0	V	
	V_{DD2}	-0.5	12.0	V	
	V_{GG}	-0.3	40.0	V	
	$V_{GG}-V_{EE}$	-	40.0	V	
	V_{EE}	-20	0.3	V	

8.Electrical Characteristics

8-1) Recommended Operating Conditions:

$V_{SS1}=V_{SS2}=GND = 0V, T_a = 25^{\circ}C$

Item	Symbol	Min.	Typ.	Max.	Unit	Remark
Supply Voltage for Source Driver	V_{DD1}	3.0	3.3	3.6	V	
	V_{DD2}	9.5	10	10.5		
Supply Voltage for Gate Driver	V_{GG}	-	17	-	V	
	V_{EE}	-	-10	-	V	
	V_{CC}	3.0	3.3	3.6	V	
Supply Voltage for Vcom	V_{com}	-	2.7	-	V	
Digital Input Voltage	V_{IH}	$0.8V_{DD1}$	-	V_{DD1}	V	
	V_{IL}	0	-	$0.2V_{DD1}$	V	

7-2) Recommended driving condition for LED backlight

$T_a = 25^{\circ}C$

Parameter	Symbol	Min	TYP	MAX	Unit	Remark
Supply voltage of LED backlight	V_{LED}	-	-	(11.4)	V	Note 7-1
Supply current of LED backlight	I_{LED1}	-	20	-	mA	Note 7-2
	I_{LED2}					
Backlight Power Consumption	P_{LED}	-	-	456	mW	Note 7-1/Note 7-3

Note 7-1 : $I_{LED}= 20mA$,constant current

Note 7-2 : The LED driving condition is defined for each LED module. (3 LED Serial)

Input current = $20mA * 2 = 40mA$

Note 7-3 : $P_{LED} = V_{LED} * I_{LED1} + V_{LED} * I_{LED2}$.

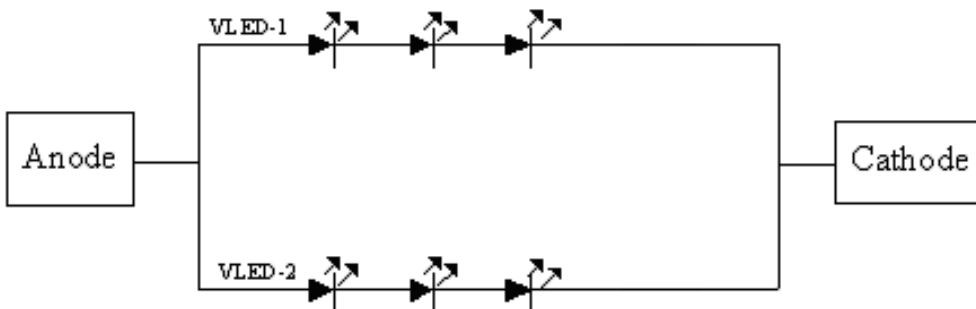

7-3) Power Consumption

Parameter	Symbol	Condition	Typ.	Max.	Unit	Remark
Supply Current for Gate Driver (Hi level)	I_{GG}	$V_{GG}=+17V$	0.12	0.15	mA	
Supply Current for Gate Driver (Low level)	I_{EE}	$V_{EE}=-10V$	0.15	0.19	mA	
Supply Current for Source Driver (Digital)	I_{DD1}	$V_{DD1}=+3.3V$	4.8	8.0	mA	
Supply Current for Source Driver (Analog)	I_{DD2}	$V_{DD2}=+10V$	16.0	30.0	mA	
Supply Current for Gate Driver (Digital)	I_{CC}	$V_{CC}=+3.3V$	0.17	0.21	mA	
LCD Panel Power Consumption	-	-	180	332	mW	
Backlight Power Consumption	P_{LED}	-	384	456	mW	
Total Power Consumption	-	-	564	788	mW	

8. Pixel Arrangement

The LCD module pixel arrangement is the stripe.

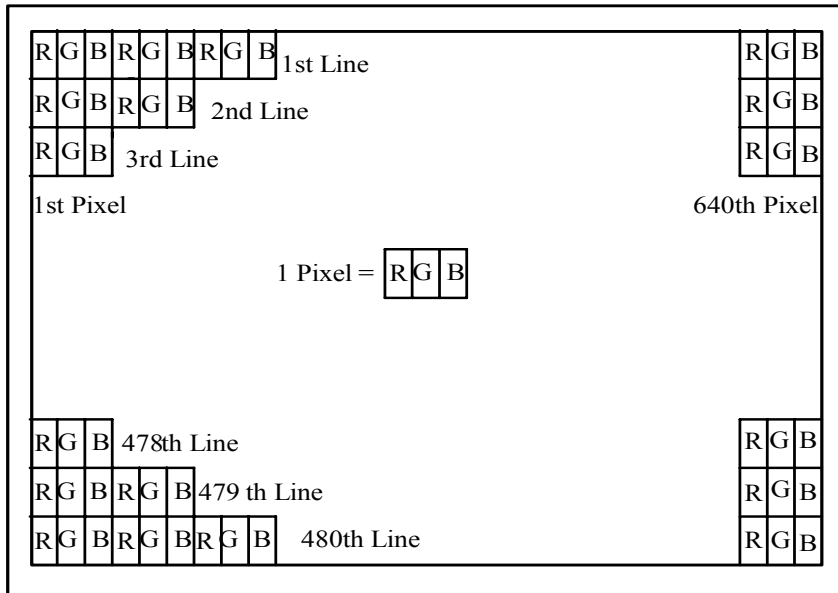

9. Display Color and Gray Scale Reference

Color		Input Color Data																	
		Red						Green						Blue					
		R5	R4	R3	R2	R1	R0	G5	G4	G3	G2	G1	G0	B5	B4	B3	B2	B1	B0
Basic Colors	Black	0	0	0	0	0	0	0	0	0	0	0	0	0	0	0	0	0	0
	Red (63)	1	1	1	1	1	1	0	0	0	0	0	0	0	0	0	0	0	0
	Green (63)	0	0	0	0	0	0	1	1	1	1	1	1	0	0	0	0	0	0
	Blue (63)	0	0	0	0	0	0	0	0	0	0	0	0	1	1	1	1	1	1
	Cyan	0	0	0	0	0	0	1	1	1	1	1	1	1	1	1	1	1	1
	Magenta	1	1	1	1	1	1	0	0	0	0	0	0	1	1	1	1	1	1
	Yellow	1	1	1	1	1	1	1	1	1	1	1	1	0	0	0	0	0	0
	White	1	1	1	1	1	1	1	1	1	1	1	1	1	1	1	1	1	1
Red	Red (00)	0	0	0	0	0	0	0	0	0	0	0	0	0	0	0	0	0	0
	Red (01)	0	0	0	0	0	1	0	0	0	0	0	0	0	0	0	0	0	0
	Red (02)	0	0	0	0	1	0	0	0	0	0	0	0	0	0	0	0	0	0
	Darker																		
	↓	↓	↓	↓	↓	↓	↓	↓	↓	↓	↓	↓	↓	↓	↓	↓	↓	↓	↓
	Brighter																		
	Red (61)	1	1	1	1	0	1	0	0	0	0	0	0	0	0	0	0	0	0
	Red (62)	1	1	1	1	1	0	0	0	0	0	0	0	0	0	0	0	0	0
Red (63)	1	1	1	1	1	1	0	0	0	0	0	0	0	0	0	0	0	0	
Green	Green (00)	0	0	0	0	0	0	0	0	0	0	0	0	0	0	0	0	0	0
	Green (01)	0	0	0	0	0	0	0	0	0	0	0	1	0	0	0	0	0	0
	Green (02)	0	0	0	0	0	0	0	0	0	0	1	0	0	0	0	0	0	0
	Darker																		
	↓	↓	↓	↓	↓	↓	↓	↓	↓	↓	↓	↓	↓	↓	↓	↓	↓	↓	↓
	Brighter																		
	Green (61)	0	0	0	0	0	0	1	1	1	1	0	1	0	0	0	0	0	0
	Green (62)	0	0	0	0	0	0	1	1	1	1	1	0	0	0	0	0	0	0
Green (63)	0	0	0	0	0	0	1	1	1	1	1	1	0	0	0	0	0	0	
Blue	Blue (00)	0	0	0	0	0	0	0	0	0	0	0	0	0	0	0	0	0	0
	Blue (01)	0	0	0	0	0	0	0	0	0	0	0	0	0	0	0	0	0	1
	Blue (02)	0	0	0	0	0	0	0	0	0	0	0	0	0	0	0	0	1	0
	Darker																		
	↓	↓	↓	↓	↓	↓	↓	↓	↓	↓	↓	↓	↓	↓	↓	↓	↓	↓	↓
	Brighter																		
	Blue (61)	0	0	0	0	0	0	0	0	0	0	0	0	1	1	1	1	0	1
	Blue (62)	0	0	0	0	0	0	0	0	0	0	0	0	1	1	1	1	1	0
Blue (63)	0	0	0	0	0	0	0	0	0	0	0	0	1	1	1	1	1	1	

10. Block Diagram

10-1) TFT-module Block Diagram

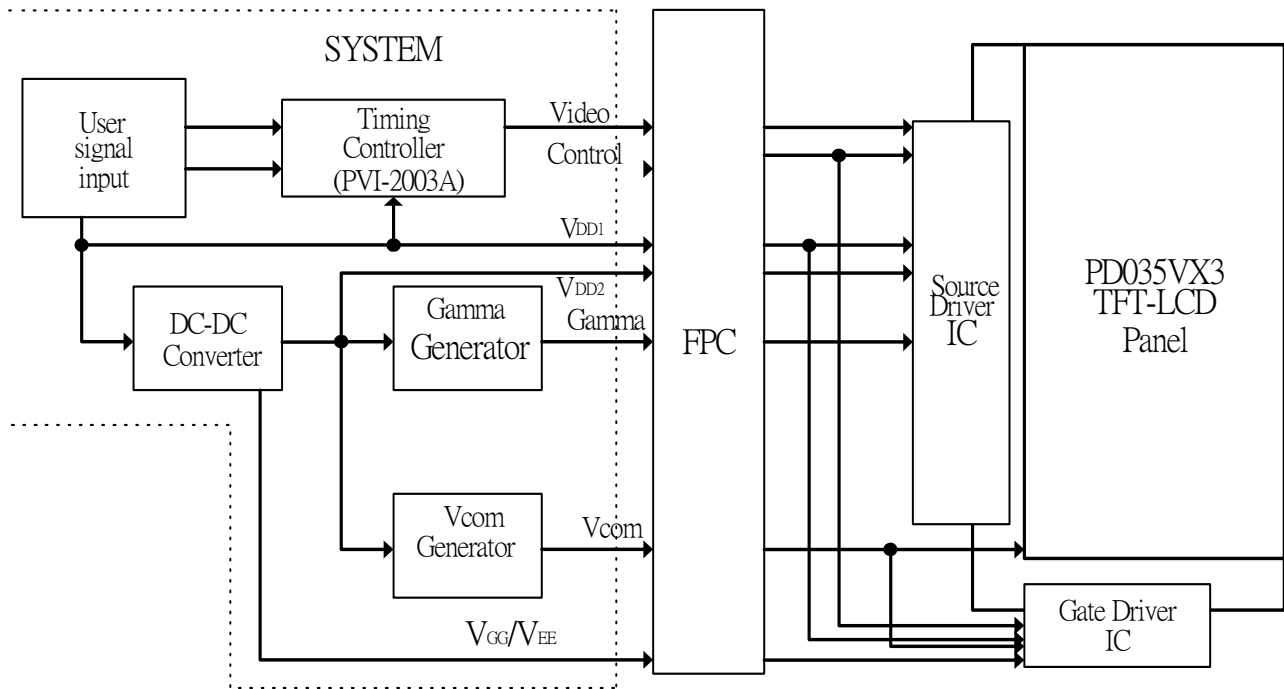

If you use PD035VX3, you can apply PVI-2003A(Timing controller) which will generate timing signals to support PD035VX3.

11. Interface Timing

11.1) Timing Parameters

AC Electrical Characteristics ($V_{CC}=V_{DD1}=3.3V$, $V_{DD2}=10V$, $GND=V_{SS1}=V_{SS2}=0V$, $T_a=25^{\circ}C$)

Parameter	Symbol	Min.	Typ.	Max.	Unit
CLK Frequency	Fclk	-	25	40	MHz
CLK Pulse Width	T _{CPH}	25	40	-	ns
Data Set-up Time	T _{su}	4	-	-	ns
Data Hold Time	T _{hd}	2	-	-	ns
Propagation Delay of DIO2/1	T _{phl}	6	10	15	ns
Time That The Last Data to LD	T _{ld}	1	-	-	T _{CPH}
Pulse width of LD	T _{wld}	2	-	-	T _{CPH}
Time That LD to DIO1/2	T _{lds}	5	-	-	T _{CPH}
POL Set-up Time	T _{psu}	6	-	-	ns
POL Hold Time	T _{phd}	6	-	-	ns
OE Pulse Width	T _{OE_V}	1	-	-	μs
CKV Pulse Width	T _{CKV}	500	-	-	ns
STV Set-up Time	T _{SUV}	400	-	-	ns
STV Hold Time	T _{HDV}	400	-	-	ns
Horizontal Display Period	T _{HDP}	-	640	-	T _{CPH}
Horizontal Period Timing Range	T _{HP}	-	800	-	T _{CPH}
Horizontal Lines Per Field	T _V	520	525	640	T _{HP}
Vertical Display Timing Range	T _{DV}	-	480	-	T _{HP}

11.2) Timing Diagram

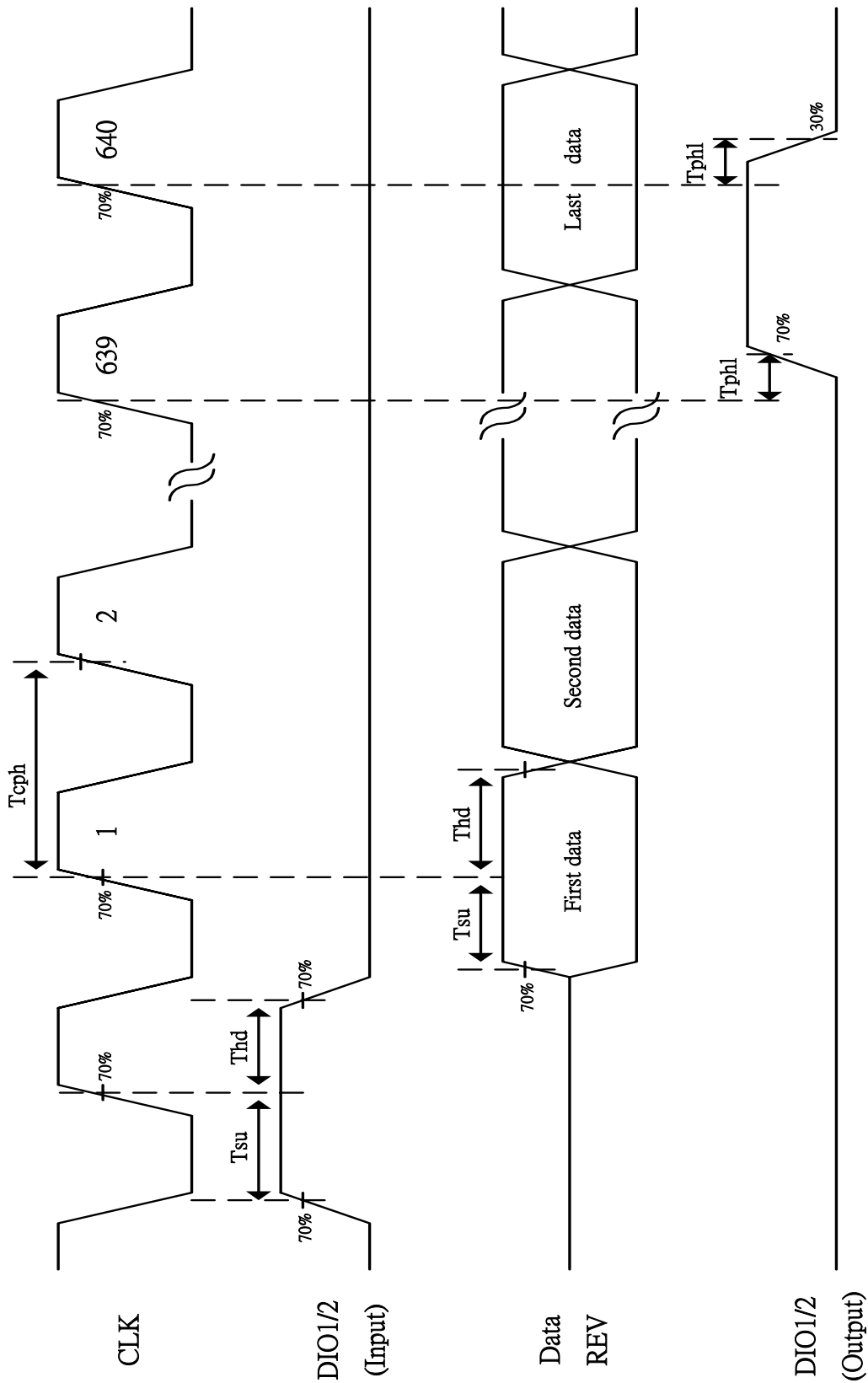

Fig. 11-1 Horizontal timing(1)

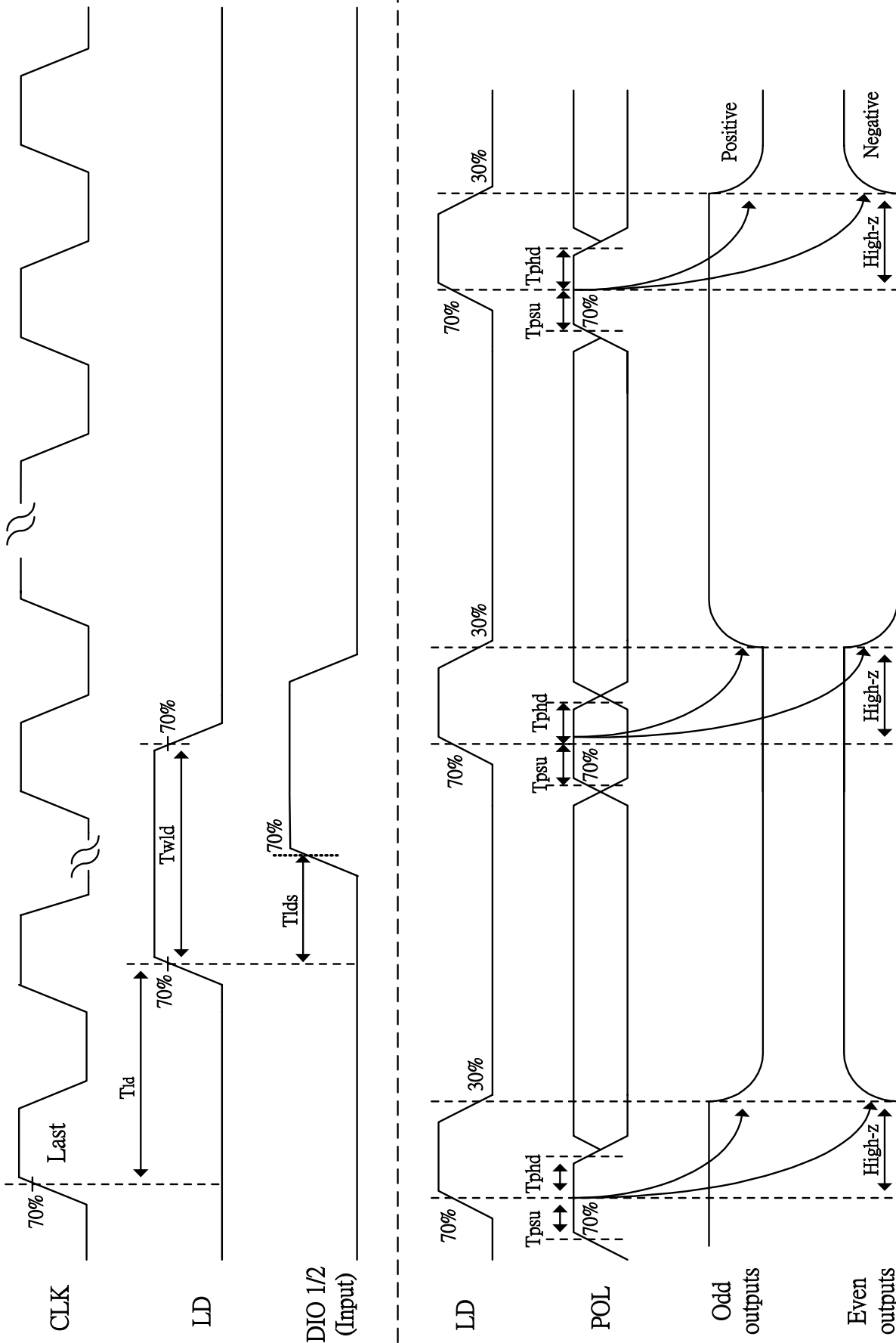

Fig. 11-2 Horizontal timing(2)

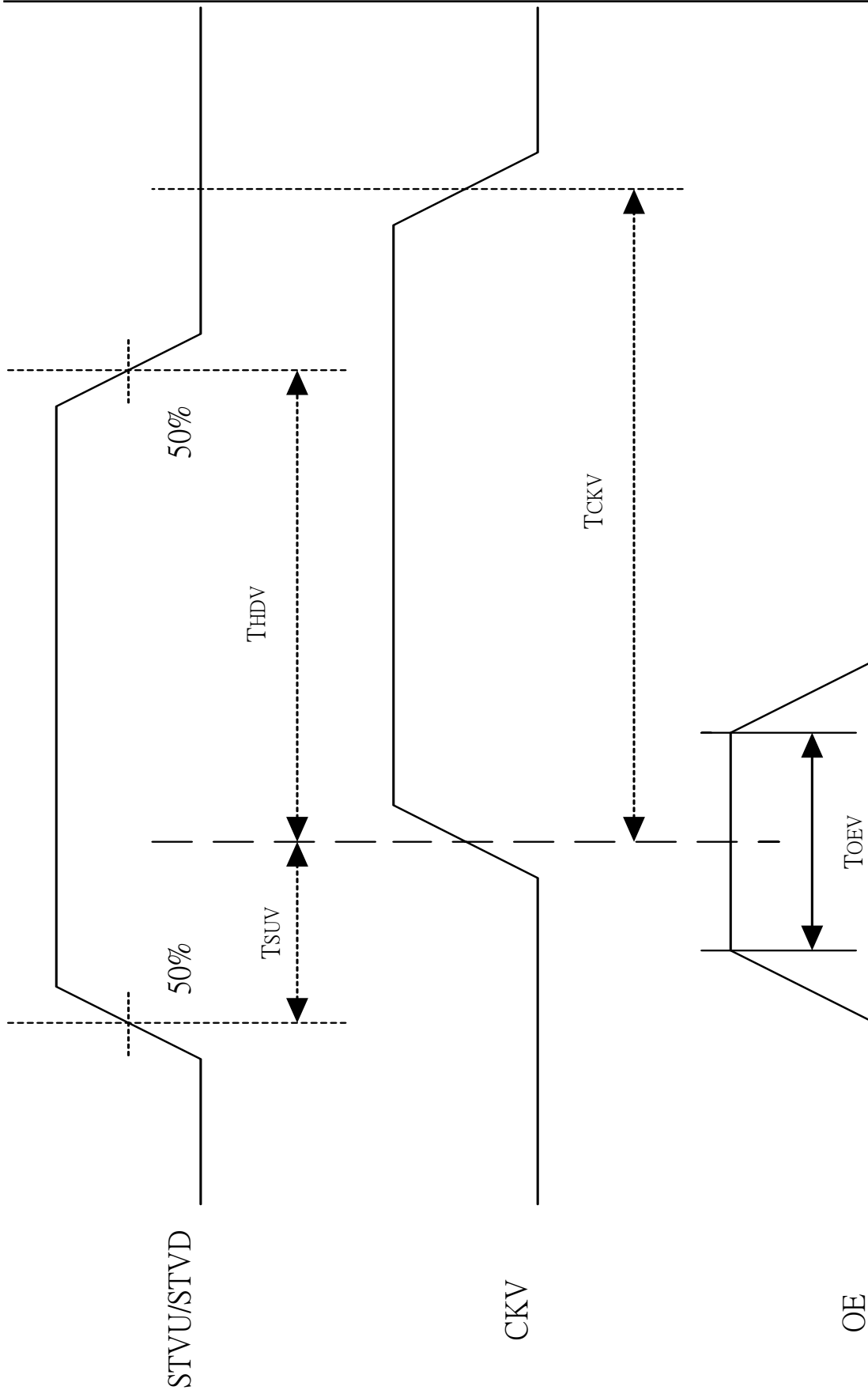

Fig. 11-3 Vertical shift clock timing

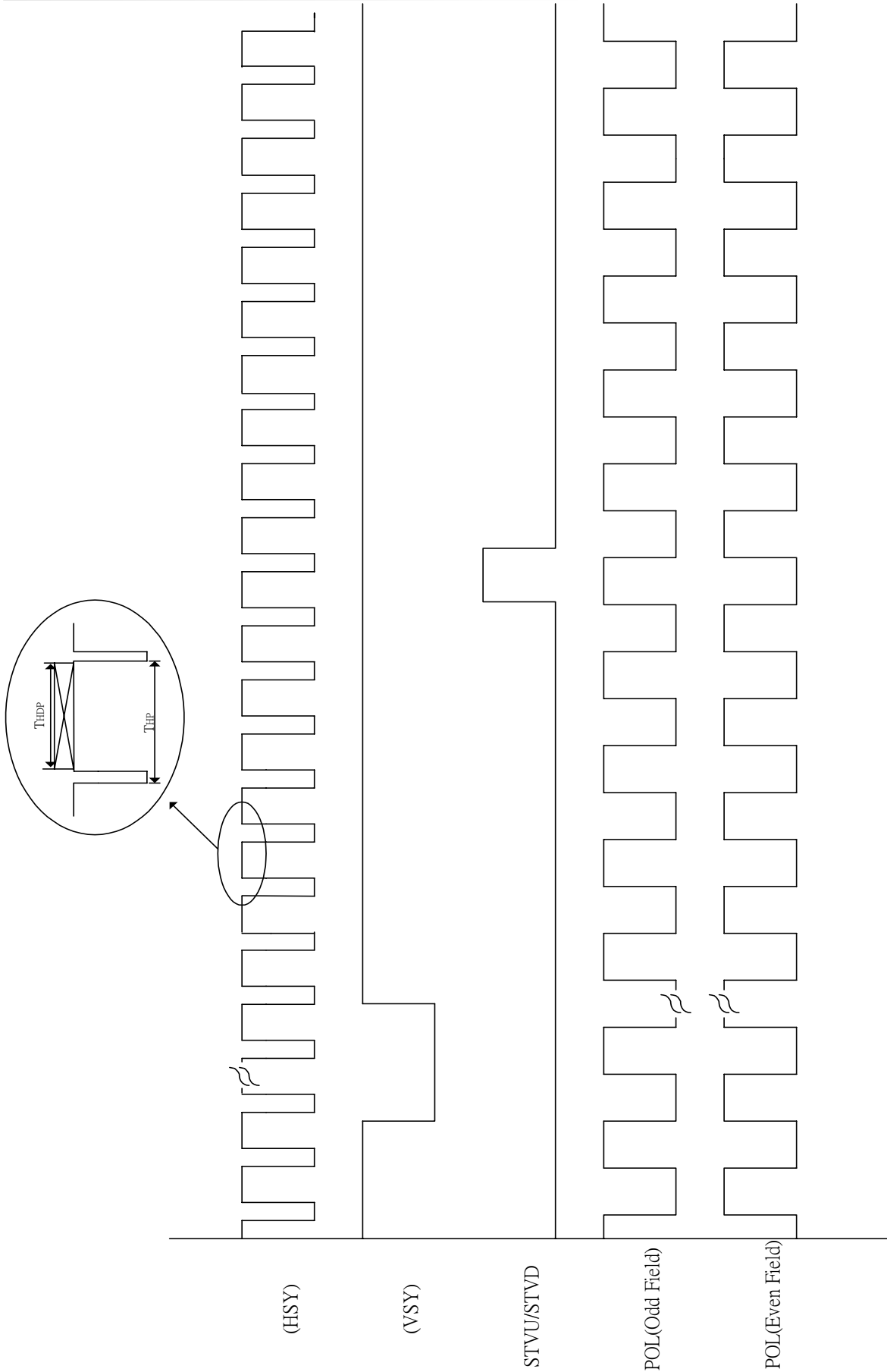
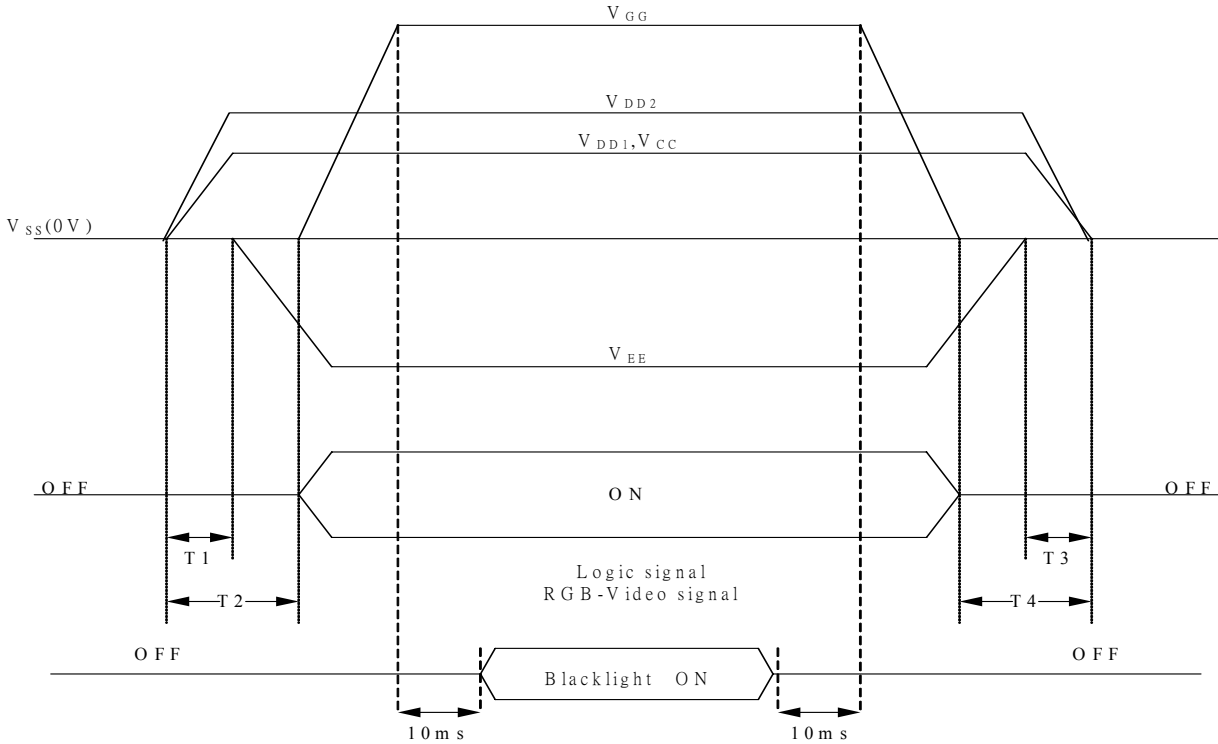

Fig. 11-4 Vertical timing

12. Power On Sequence



- 1) $10\text{ms} \leq T_1 < T_2$
- 2) $0\text{ms} < T_3 \leq T_4 \leq 10\text{ms}$

13. Optical Characteristics

13-1) Specification:

T_a=25°C

Parameter	Symbol	Condition	MIN.	TYP.	MAX.	Unit	Remarks
Viewing Angle	Horizontal	θ_{21}, θ_{22}	± 45	± 50	-	deg	Note 14-2
	Vertical	θ_{12} (to 12 o'clock)	10	15	-	deg	
		θ_{11} (to 6 o'clock)	30	35	-	deg	
Contrast Ratio	CR	At optimized Viewing angle	200	400	-	-	Note 14-4
Response time	Rise	Tr	-	15	30	ms	Note 14-3
	Fall	Tf	-	25	50	ms	
Brightness	L	$\theta = 0^\circ$	170	200	-	cd/m ²	Note 14-1
Uniformity	U	9 point	70	75	-	%	Note 14-5
Cross Talk	-	$\theta = 0^\circ$	-	-	3.0	%	Note 14-6
White Chromaticity	x	$\theta = 0^\circ$	0.28	0.31	0.34	-	Note 14-1
	y		0.30	0.33	0.36	-	
LED Life Time	-	-	-	30000	-	hrs	

All the optical measurement shall be executed 1 minute after backlight being turn-on. The optical characteristics shall be measured in dark room (ambient illumination on panel surface less than 1 Lux). The measuring configuration shows as following figure.

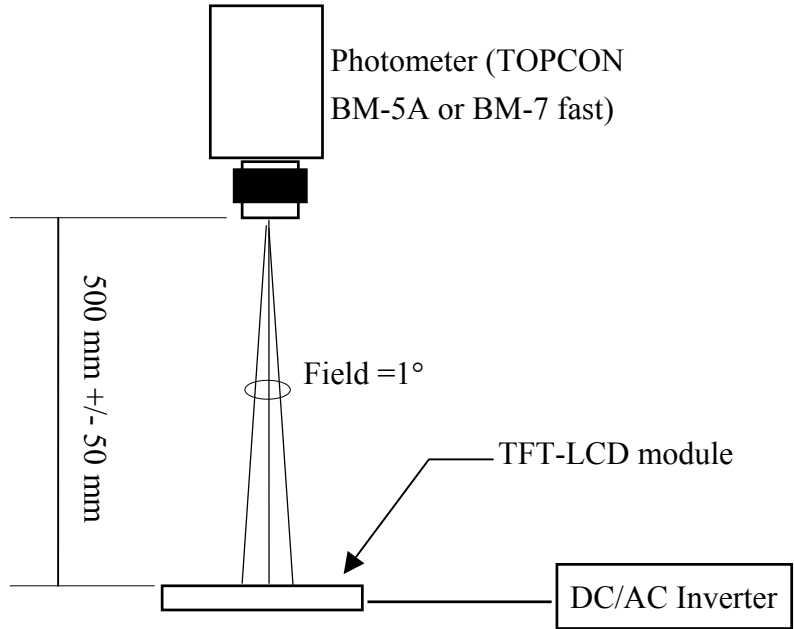

Optical characteristics measuring configuration

Note 14-1: 1.Topcon BM-5A or BM-7 fast luminance meter 1° field of view is used in the testing .

Note 14-2: The definitions of viewing angles are as follow

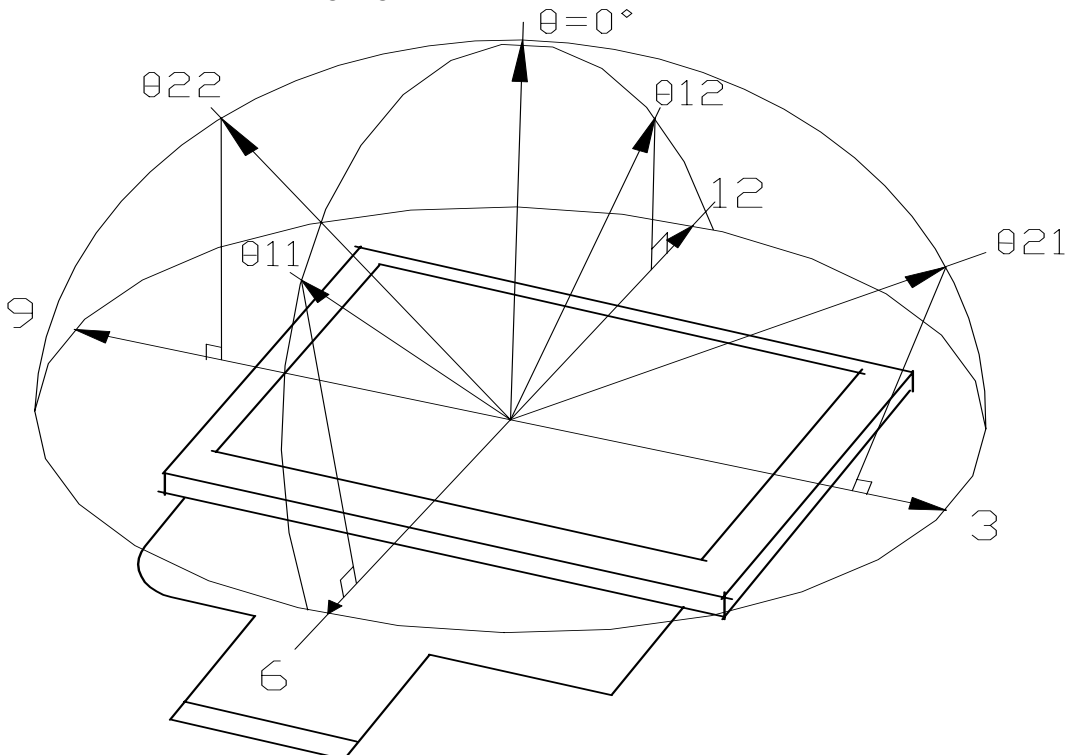

Note 14-3: Definition of Response Time T_r and T_f :

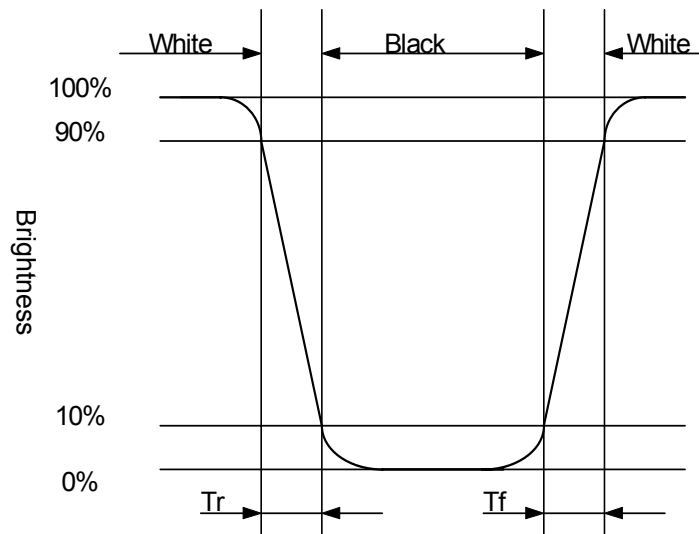

Note 14-4: The definition of contrast ratio $CR = \frac{\text{Luminance at gray level 63}}{\text{Luminance at gray level 0}}$

Note 14-5 : The uniformity of LCD is defined as

$$U = \frac{\text{The Minimum Brightness of the 9 testing Points}}{\text{The Maximum Brightness of the 9 testing Points}}$$

Luminance meter : BM-5A or BM-7 fast (TOPCON)

Measurement distance : 500 mm +/- 50 mm

Ambient illumination : < 1 Lux

Measuring direction : Perpendicular to the surface of module

The test pattern is white (Gray Level 63).

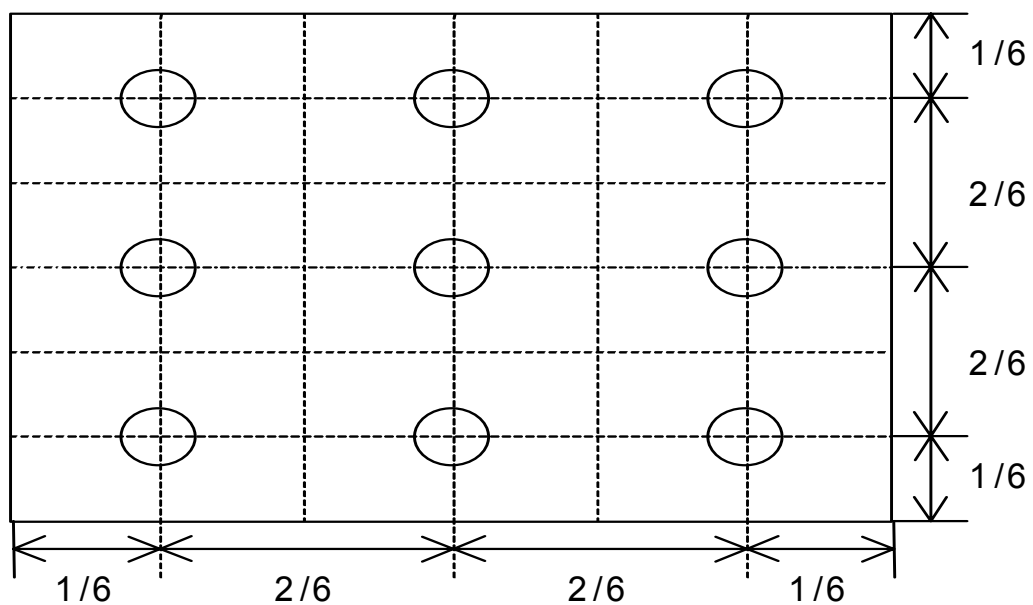

Note 14-6 : Cross Talk (CTK) = $\frac{|Y_A - Y_B|}{Y_A} \times 100\%$

Y_A : Brightness of Pattern A

Y_B : Brightness of Pattern B

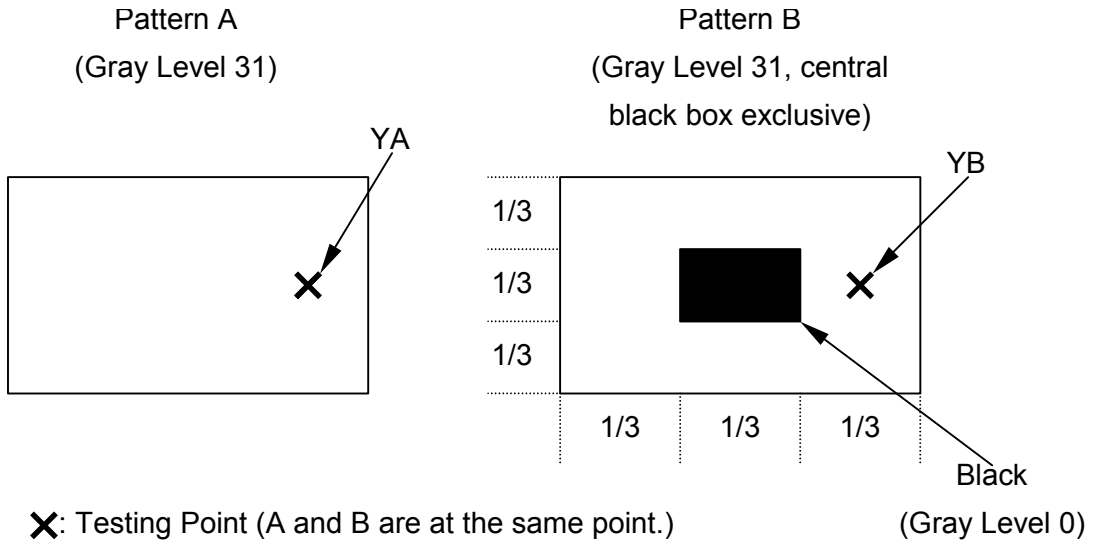

14. Handling Cautions

15-1) Mounting of module

- a) Please power off the module when you connect the input/output connector.
- b) Polarizer which is made of soft material and susceptible to flaw must be handled carefully.
- c) Protective film (Laminator) is applied on surface to protect it against scratches and dirt. It is recommended to peel off the laminator before use and taking care of static electricity.

15-2) Precautions in mounting

- a) Wipe off water drops or finger grease immediately. Long contact with water may cause discoloration or spots.
- b) TFT-LCD module uses glass which breaks or cracks easily if dropped or bumped on hard surface. Please handle with care.
- c) Since CMOS LSI is used in the module. So take care of static electricity and earth yourself when handling.

15-3) Precautions about touch panel

- a) Input must be performed through a special designed stylus only. Do not pile up the products or put any heavy things on it.

15-4) Others

- a) Do not expose the module to direct sunlight or intensive ultraviolet rays for many hours.
- b) Store the module at a room temperature place.
- c) The voltage of beginning electric discharge may over the normal voltage because of leakage current from approach conductor by to draw lump read lead line around.
- d) If LCD panel breaks, it is possibly that the liquid crystal escapes from the panel.
Avoid putting it into eyes or mouth. When liquid crystal sticks on hands, clothes or feet.
Wash it out immediately with soap.
- e) Observe all other precautionary requirements in handling general electronic components.

15. Reliability Test

No	Test Item	Test Condition
1	High Temperature Storage Test	Ta = +70°C, 240 hrs
2	Low Temperature Storage Test	Ta = -30°C, 240 hrs
3	High Temperature Operation Test	Ta=+60°C, 240 hrs
4	Low Temperature Operation Test	Ta=-20°C, 240 hrs
5	High Temperature & High Humidity Operation Test	Ta = +60°C, 90%RH, 240 hrs (No Condensation)
6	Thermal Cycling Test (non-operating)	-20°C → +70°C, 100 Cycles 30min 30min
7	Vibration Test (non-operating)	Frequency : 10 ~ 55 Hz Amplitude : 1.0 mm Sweep time : 11 mins Test Period : 6 Cycles for each direction of X, Y, Z
8	Shock Test (non-operating)	100G, 6ms Direction : ±X, ±Y, ±Z Cycle : 3 times
9	Electrostatic Discharge Test (non-operating)	200pF, 0Ω ±200V 1 time / each terminal
10	Hitting Durability Test (Touch panel)	1,000,000 times, with R 8.0 mm silicon rubber, 200g, 3times/sec
11	Sliding Durability Test (Touch panel)	100,000 times, with R 0.8 mm polyacetal stylus, 200g, 60mm/sec

Ta: ambient temperature

[Criteria]

In the standard conditions, there is not display function NG issue occurred. (including : line defect ,no image). All the cosmetic specification is judged before the reliability stress.

16. Packing

REV	DESCRIPTION	DESIGN	DATE
01	INITIAL RELEASE	Dennis chen	2006.01.08
02	CANCEL EXTERNAL CARTON 50-0100101	Ethan chen	2007.12.05

NOTE:

- One layer include: 1 piece of cushion sheet, 12 pcs panel & 1 piece of tray.
- Q'TY: 120 pcs panel/carton.
- Dimension: 455*375*190mm
- Weight: 9.0 KG
- tray需180°交叉堆疊, 堆疊後可從側邊檢視圓弧防呆方向是否正確

ITEM	PART NO.	DESCRIPTION	QTY	REMARK
6	50-0100091	CARTON INTERNAL	1	
5	50-0500041	摺口袋450*380*700mm	1	抗靜電
4		PD035VX3	120	
3	50-0200072	EPE CUSHION SHEET	10	抗靜電
2	50-0301381	TRAY	11	抗靜電
1	50-0300491	EPE FOAM	2	

MTL.SPEC.		UNSPECIFIED TOL'S		REMARK		元太科技股份有限公司 Prime View International Co.,Ltd.	
		ANGLE					
		ROUGHNESS				DWG.TITLE PD035VX3 PACKING Dim	
APPROVE	Frank Shin	'06.01.08	SCALE	UNIT	SHEET		
CHECK	Frank Shin	'06.01.08	1:1	mm	1 OF 1	DWG.NO.	
DESIGN	Dennis	'06.01.08	MTL.NO.				
						REV. 01	A4 SIZE

Appendix

