

TFT-Display Datenblatt

Modell PD040QX1

Kurzdaten

Hersteller	PrimeView
Diagonale	4,0" / 10,2cm
Format	4:3
Auflösung	320x240
Backlight	LED/350cd/m ²
Temperatur	-30...+80°C (Betrieb)

Version : 2.0



Inselkammerstr. 10
82008 Unterhaching
Tel: +49 89 614 503 40
www.hy-line.de/computer

TECHNICAL SPECIFICATION

MODEL NO : PD040QX1

The content of this information is subject to be changed without notice.
Please contact PVI or its agent for further information.

Customer's Confirmation

Customer _____

Date _____

By _____

PVI's Confirmation

Zmyy Chang
Confirmed By _____

曾耀遠
Prepared By _____

Revision History

Rev.	Issued Date	Revised Contents
1.0	December, 5, 2007	New
2.0	March.24.2008	Add Page 29 15.Handling Cautions 15-1 item D) Modify Page 4 3. Mechanical Specifications Page 9 Note 5-2

TECHNICAL SPECIFICATION CONTENTS

NO.	ITEM	PAGE
-	Cover	1
-	Revision History	2
-	Contents	3
1	Application	4
2	Features	4
3	Mechanical Specifications	4
4	Mechanical Drawing of TFT-LCD module	5
5	Input / Output Terminals	6
6	Absolute Maximum Ratings	10
7	Electrical Characteristics	10
8	Pixel Arrangement	11
9	Display Color and Gray Scale Reference	12
10	Operation description	13
11	AC Characteristics	21
12	Waveform	22
13	Power On Sequence	26
14	Optical Characteristics	36
15	Handling Cautions	29
16	Reliability Test	30
17	Block Diagram	31
18	Packing	32

1. Application

This data sheet applies to a color TFT LCD module, PD040QX1. This module applies to OA product (must use Analog to Digital driving board), which requires high quality flat panel display. If you must use in severe reliability environments, please don't extend over PVI's reliability test conditions.

2. Features

- . Amorphous silicon TFT LCD panel with LED back-light unit
- . Pixel in stripe configuration
- . Slim and compact, designed for O/A application
- . TTL transmission interface

3. Mechanical Specifications

Parameter	Specifications	Unit
Screen Size	4 (diagonal)	inch
Display Format	320×(RGB)×240	dot
Active Area	81.12 (H)×60.84 (V)	mm
Pixel Pitch	0.2535(H)×0.2535 (V)	mm
Pixel Configuration	Stripe	
Display Colors	16.7M	
Surface Treatment	Anti-Glare +EWV	
Back-light	8-LEDs	
Outline Dimension	93.00(W)×73.50 (H)×4.9 (D)(typ.)	mm
Weight	46±5	g
Display mode	Normally white	
Gray scale inversion direction	6 (ref to Note 14-1)	o'clock

4. Mechanical Drawing of TFT-LCD Module

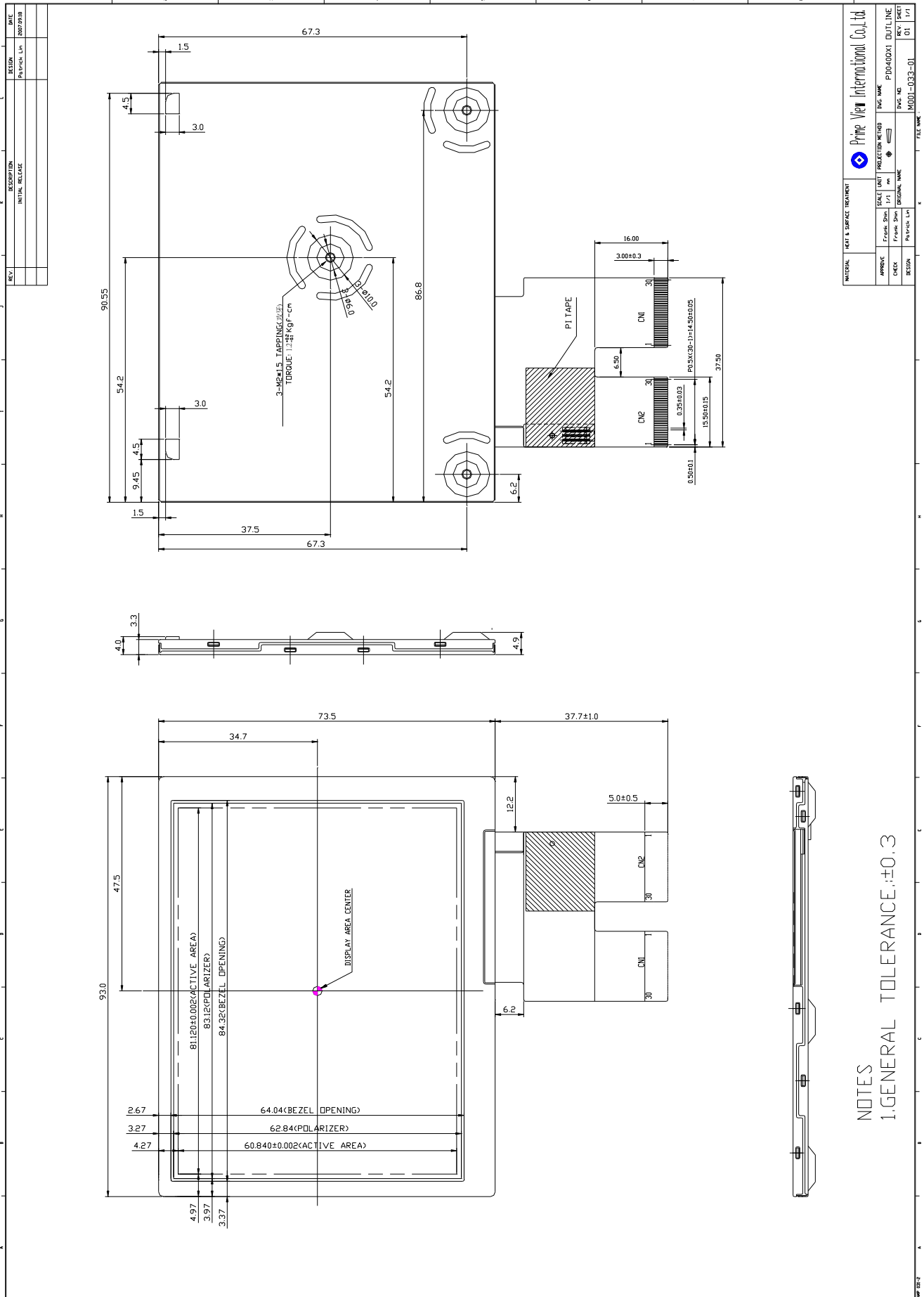

5. Input / Output Terminals
5-1) TFT-LCD Panel Driving

FPC Down Connect, 30 Pins, Pitch: 0.5 mm

CN 1

Pin No.	Symbol	Function	Remark
1	D27(B7)	Blue Data	Note 5-1
2	D26(B6)	Blue Data	
3	D25(B5)	Blue Data	
4	D24(B4)	Blue Data	
5	D23(B3)	Blue Data	
6	D22(B2)	Blue Data	
7	D21(B1)	Blue Data	
8	D20(B0)	Blue Data	
9	GND	Digital ground	
10	D17(G7)	Green Data	Note 5-1
11	D16(G6)	Green Data	
12	D15(G5)	Green Data	
13	D14(G4)	Green Data	
14	D13(G3)	Green Data	
15	D12(G2)	Green Data	
16	D11(G1)	Green Data	
17	D10(G0)	Green Data	
18	GND	Digital ground	
19	D07(R7)	Red Data	Note 5-1
20	D06(R6)	Red Data	
21	D05(R5)	Red Data	
22	D04(R4)	Red Data	
23	D03(R3)	Red Data	
24	D02(R2)	Red Data	
25	D01(R1)	Red Data	
26	D00(R0)	Red Data	
27	GND	Digital ground	
28	VEE	Negative power for gate driver	Note 5-8
29	VCC2	Digital power supply for gate driver	Note 5-9
30	VGG	Positive power for gate driver	Note 5-10

CN 2

Pin No.	Symbol	Function	Remark
1	VLED	Voltage for LED	
2	GLED2	LED ground	
3	GLED2	LED ground	
4	GND	Digital ground	
5	VCOM	Voltage for common electrode	Note 5-7
6	VSET	Externally/Internally gamma voltage setup	Note 5-11
7	VDDA	Analog power supply for source driver	Note 5-2
8	V10	Gamma correction voltage 10	
9	V9	Gamma correction voltage 9	
10	V8	Gamma correction voltage 8	
11	V7	Gamma correction voltage 7	
12	V6	Gamma correction voltage 6	
13	V5	Gamma correction voltage 5	
14	V4	Gamma correction voltage 4	
15	V3	Gamma correction voltage 3	
16	V2	Gamma correction voltage 2	
17	V1	Gamma correction voltage 1	
18	VSSA	Analog ground for source drive	
19	L/R	Left/Right control for source driver	Note 5-12
20	U/D	Up/Down control for gate driver	Note 5-12
21	GND	Digital ground	
22	VCC1	Digital power supply for source driver	Note 5-6
23	RESETB	Hardware global reset	
24	SPDA	Serial port data input/output	
25	SPCK	Serial port clock	
26	SPENA	Serial port data enable signal	
27	DEN	Input data enable control	Note 5-5
28	HS	Horizontal sync input	Note 5-3
29	VS	Vertical sync input	Note 5-4
30	CLK	Clock signal. Latching data at the rising edge	

Note 5-1 : Digital data input. DX0 is LSB and DX7 is MSB.

If parallel RGB input mode is used, D0X, D1X, and D2X indicate R, G and B data in turn.
If serial RGB or CCIR601/656 input mode is selected, only D07~D00 are used, and others short to GND.

Note 5-2 : VDDA Typ. = 9.6V

Note 5-3 : Horizontal sync input in digital RGB mode and CCIR601 mode.
(Short to GND if not used)

Note 5-4 : Vertical sync input in digital RGB mode and CCIR601 mode.
(Short to GND if not used)

Note 5-5 : The SYNC(HS+VS) Mode and DEN mode are supported. If DEN signal is fixed low, SYNC Mode is used. Otherwise , DEN mode is used.

Note 5-6 : VCC1 Typ. = 3.3V

Note 5-7 : VCOM Typ. = 3.68V

Note 5-8 : VEE Typ. = -8V

Note 5-9 : VCC2 Typ. = 3.3V

Note 5-10 : VGG Typ. = 17V

Note 5-11 : If VSET="H", the gamma correction voltage generated externally.

Note 5-12 : The definition of L/R , U/D

U/D CN2(PIN20)= Low
L/R CN2(PIN19)=High

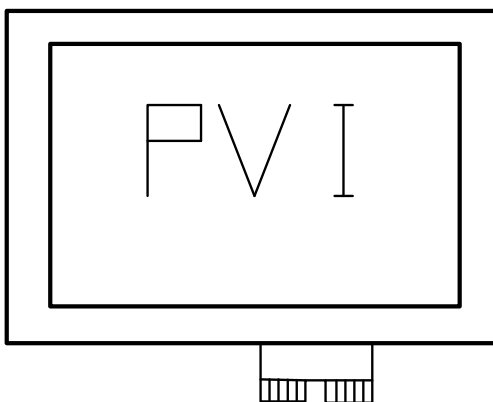

U/D CN2(PIN20)= High
L/R CN2(PIN19)=Low

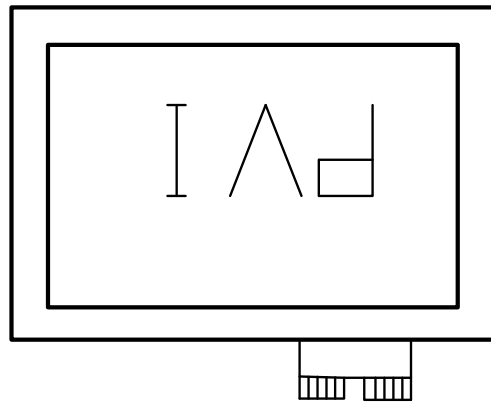

Typical Application Circuit (When VDDA = 9.6V)

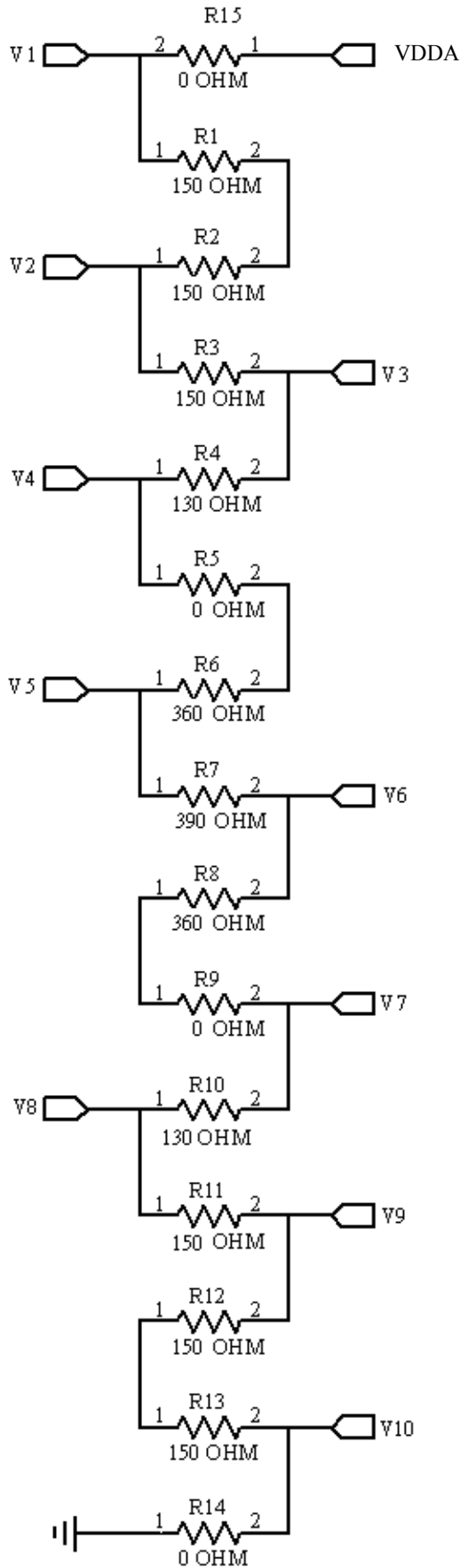

6. Absolute Maximum Ratings:

GND=0V, Ta=25°C

Parameters	Symbol	MIN.	MAX.	Unit	Remark
Supply Voltage	VCC2	-0.3	6.0	V	
	VCC1	-0.3	7.0	V	
	VDDA	-0.3	13.5	V	
	VGG	-0.3	40.0	V	
	VGG-VEE	-0.3	40.0	V	
	VEE	-20	0.3	V	

7. Electrical Characteristics

7-1) Recommended Operating Conditions:

VSSA=GND=0V, Ta=25°C

Item	Symbol	Min.	Typ.	Max.	Unit	Remark
Supply Voltage for Source Driver	VCC1	2.7	3.3	3.6	V	Note 7-1
	VDDA	6.5	9.6	13.5	V	
Supply Voltage for Gate Driver	VGG	-	17	-	V	
	VEE	-	-8	-	V	
	VCC2	2.7	3.3	3.6	V	
VCOM Voltage	VCOM	-	4.1	-	V	
Digital Input Voltage	V _{IH}	0.7 V _{CC}	-	V _{CC}	V	
	V _{IL}	0	-	0.3 V _{CC}	V	

Note 7-1 : To test the current dissipation of V_{CC}, using the “color bars” testing pattern shown as below.

1	2	3	4	5	6	7	8
---	---	---	---	---	---	---	---

1. White
2. Yellow
3. Cyan
4. Green
5. Magenta
6. Red
7. Blue
8. Black

I_{DD} current dissipation testing pattern

7-2) Recommended Driving Condition for Back Light

Ta=25°C

Parameter	Symbol	Min.	Typ.	Max.	Unit	Remark
Supply voltage of LED backlight	V _{LED}	-	-	(14)	V	Note 7-2
Supply current of LED backlight	I _{LED}	-	20	-	mA	Note 7-3
Backlight Power Consumption	P _{LED}	-	-	560	mW	Note 7-2、7-4

Note 7-2 : I_{LED}= 20mA, constant current

Note 7-3 : The LED driving condition is defined for each LED module. (4 LED Serial)

Input current = 20mA * 2 = 40mA

Note 7-4 : P_{LED} = V_{LED-1} * I_{LED-1} + V_{LED-2} * I_{LED-2}

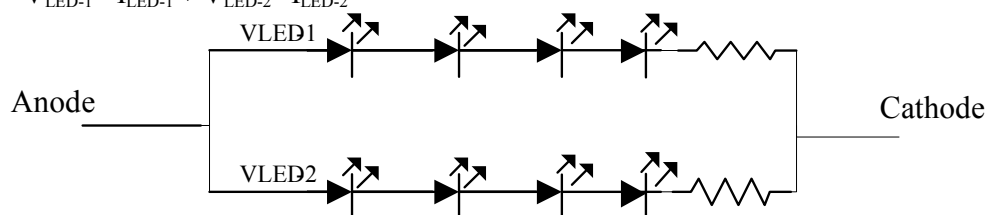

7-3) Power Consumption

Parameter	Symbol	Condition	Typ.	Max.	Unit	Remark
Supply Current for Gate Driver (Hi level)	IGG	VGG= 17V	0.1	0.3	mA	
Supply Current for Gate Driver (Low level)	IEE	VEE= -8V	0.1	0.3	mA	
Supply Current for Gate Driver (Digital)	ICC2	VCC2= 3.3V	0.1	0.2	mA	
Supply Current for Source Driver (Digital)	ICC1	VCC1= 3.3V	0.9	1.8	mA	
Supply Current for Source Driver (Analog)	IDD	VDD= 9.6V	4.6	9.2	mA	
LCD Panel Power Consumption	-	-	49.96	102.42	mW	Note 7-5
Backlight LED Power Consumption	P _{LED}	-	512	560	mW	Note 7-6
Total Power Consumption	-	-	561.96	662.42	mW	

Note 7-5: The power consumption for backlight is not included.

Note 7-6: Back light power consumption is calculated by $I_L \times V_L$.

8. Pixel Arrangement

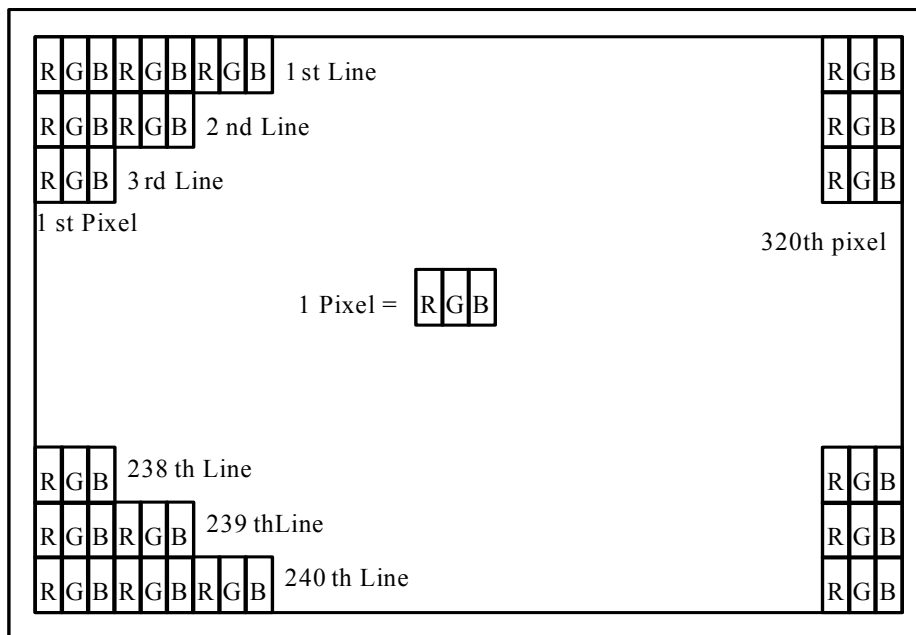

9. Display Color and Gray Scale Reference

Color		Input Color Data																							
		Red								Green								Blue							
		R7	R6	R5	R4	R3	R2	R1	R0	G7	G6	G5	G4	G3	G2	G1	G0	B7	B6	B5	B4	B3	B2	B1	B0
Basic Colors	Black	0	0	0	0	0	0	0	0	0	0	0	0	0	0	0	0	0	0	0	0	0	0	0	0
	Red	1	1	1	1	1	1	1	1	0	0	0	0	0	0	0	0	0	0	0	0	0	0	0	0
	Green	0	0	0	0	0	0	0	0	1	1	1	1	1	1	1	1	0	0	0	0	0	0	0	0
	Blue	0	0	0	0	0	0	0	0	0	0	0	0	0	0	0	0	1	1	1	1	1	1	1	1
	Cyan	0	0	0	0	0	0	0	0	1	1	1	1	1	1	1	1	1	1	1	1	1	1	1	1
	Magent	1	1	1	1	1	1	1	1	0	0	0	0	0	0	0	0	1	1	1	1	1	1	1	1
	Yellow	1	1	1	1	1	1	1	1	1	1	1	1	1	1	1	1	0	0	0	0	0	0	0	0
	White	1	1	1	1	1	1	1	1	1	1	1	1	1	1	1	1	1	1	1	1	1	1	1	1
Red	Red	0	0	0	0	0	0	0	0	0	0	0	0	0	0	0	0	0	0	0	0	0	0	0	
	Red	0	0	0	0	0	0	0	1	0	0	0	0	0	0	0	0	0	0	0	0	0	0	0	
	Red	0	0	0	0	0	0	1	0	0	0	0	0	0	0	0	0	0	0	0	0	0	0	0	
	Darker																								
	↓	↓	↓	↓	↓	↓	↓	↓	↓	↓	↓	↓	↓	↓	↓	↓	↓	↓	↓	↓	↓	↓	↓	↓	
	Brighte																								
	Red	1	1	1	1	1	1	0	1	0	0	0	0	0	0	0	0	0	0	0	0	0	0	0	
	Red	1	1	1	1	1	1	1	0	0	0	0	0	0	0	0	0	0	0	0	0	0	0	0	
	Red	1	1	1	1	1	1	1	1	0	0	0	0	0	0	0	0	0	0	0	0	0	0	0	
Green	Green	0	0	0	0	0	0	0	0	0	0	0	0	0	0	0	0	0	0	0	0	0	0	0	
	Green	0	0	0	0	0	0	0	0	0	0	0	0	0	0	1	0	0	0	0	0	0	0	0	
	Green	0	0	0	0	0	0	0	0	0	0	0	0	0	1	0	0	0	0	0	0	0	0	0	
	Darker																								
	↓	↓	↓	↓	↓	↓	↓	↓	↓	↓	↓	↓	↓	↓	↓	↓	↓	↓	↓	↓	↓	↓	↓	↓	
	Brighte																								
	Green	0	0	0	0	0	0	0	0	1	1	1	1	1	1	0	1	0	0	0	0	0	0	0	
	Green	0	0	0	0	0	0	0	0	1	1	1	1	1	1	1	0	0	0	0	0	0	0	0	
	Green	0	0	0	0	0	0	0	0	1	1	1	1	1	1	1	1	0	0	0	0	0	0	0	
Blue	Blue	0	0	0	0	0	0	0	0	0	0	0	0	0	0	0	0	0	0	0	0	0	0	0	
	Blue	0	0	0	0	0	0	0	0	0	0	0	0	0	0	0	0	0	0	0	0	0	0	1	
	Blue	0	0	0	0	0	0	0	0	0	0	0	0	0	0	0	0	0	0	0	0	0	1	0	
	Darker																								
	↓	↓	↓	↓	↓	↓	↓	↓	↓	↓	↓	↓	↓	↓	↓	↓	↓	↓	↓	↓	↓	↓	↓	↓	
	Brighte																								
	Blue	0	0	0	0	0	0	0	0	0	0	0	0	0	0	0	0	1	1	1	1	1	1	0	
	Blue	0	0	0	0	0	0	0	0	0	0	0	0	0	0	0	0	1	1	1	1	1	1	1	
	Blue	0	0	0	0	0	0	0	0	0	0	0	0	0	0	0	0	1	1	1	1	1	1	1	

10. Operation description

10-1) SPI Register Description

Register Name	Test RW	Address				Data							
		A3	A2	A1	A0	D7	D6	D5	D4	D3	D2	D1	D0
R0	0	0	0	0	0	△	△	△	△	△	PSC	STB	RESETB
						△	△	△	△	△	0	0	1
R1	0	0	0	0	1	△	△	△	RESL1	RESL0	IF2	IF1	IF0
						△	△	△	1	0	0	0	0
R2	0	0	0	1	0	△	△	STHD5	STHD4	STHD3	STHD2	STHD1	STHD0
						△	△	0	0	0	0	0	0
R3	0	0	0	1	1	△	△	STVP3	STVP2	STVP1	STVP0	FRAD1	FRAD0
						△	△	0	0	0	0	0	0
R4	0	0	1	0	0	CS	FRP	FRC	LPF	VS_POL	HS_POL	NPC_SET	NPC_IN
						1	0	0	1	0	0	0	0
R5	0	0	1	0	1	AUTO_DP	DSIP_ON	A_TIME1	A_TIME.	B_TIME2	B_TIME1	B_TIME0	1
						1	0	0	1	0	1	0	1

△ RW must always keep low

Register

Bit	D7	D6	D5	D4	D3	D2	D1	D0
Name	reserved	reserved	reserved	reserved	reserved	reserved	reserved	RESETB
Default	-	-	-	-	-	-	-	1

RESETB: Global reset.

RESETB="L", global reset the whole chip.

RESETB="H", Normal operation.

Register R1

Bit	D7	D6	D5	D4	D3	D2	D1	D0
Name	reserved	reserved	reserved	RESL1	RESL0	IF2	IF1	IF0
Default	-	-	-	1	0	0	0	1

Register R1 setting
RESL [1:0]:Display resolution selection

RESL1	RESL0	Resolution
0	0	320×RGB×240
0	1	reserved
1	0	reserved
1	1	reserved

Display resolution selection
IF[2:0]:Data input mode selection

IF2	IF1	IF0	Data input format	operating freq
0	0	0	reserved	reserved
0	0	1	24-bis parallel RGB	25.175MHz(MAX)
0	1	0	reserved	reserved
0	1	1	reserved	reserved
1	0	0	reserved	reserved
1	0	1	reserved	reserved
1	1	0	reserved	reserved
1	1	1	reserved	reserved

Data input mode selection
Register R2

Bit	D7	D6	D5	D4	D3	D2	D1	D0
Name	reserved	reserved	STHD5	STHD4	STHD3	STHD2	STHD1	STHD0
Default	-	-	0	0	0	0	0	0

Register R2 setting

STHD[5:0]:adjust start pulse position by dot

STHD5	STHD4	STHD3	STHD2	STHD1	STHD0	STH position sadjust	Unit
0	0	0	0	0	0	0	TCPH
0	0	0	0	0	1	+1	TCPH
0	0	0	0	1	0	+2	TCPH
0	0	0	0	1	1	+3	TCPH
0	0	0	1	0	0	+4	TCPH
0	0	0	1	0	1	+5	TCPH
0	0	0	1	1	0	+6	TCPH
0	0	0	1	1	1	+7	TCPH
0	1	1	0	0	0	+24	TCPH
0	1	1	0	0	1	+25	TCPH
0	1	1	0	1	0	+26	TCPH
0	1	1	0	1	1	+27	TCPH
0	1	1	1	0	0	+28	TCPH
0	1	1	1	0	1	+29	TCPH
0	1	1	1	1	0	+30	TCPH
0	1	1	1	1	1	+31	TCPH
1	0	0	0	0	0	-1	TCPH
1	0	0	0	0	1	-2	TCPH
1	0	0	0	1	0	-3	TCPH
1	0	0	0	1	1	-4	TCPH
1	0	0	1	0	0	-5	TCPH
1	0	0	1	0	1	-6	TCPH
1	0	0	1	1	0	-7	TCPH
1	0	0	1	1	1	-8	TCPH
0	0	0	0	0	0	-25	TCPH
0	0	0	0	0	1	-26	TCPH
0	0	0	0	1	0	-27	TCPH
0	0	0	0	1	1	-28	TCPH
0	0	0	1	0	0	-29	TCPH
0	0	0	1	0	1	-30	TCPH
0	0	0	1	1	0	-31	TCPH
0	0	0	1	1	1	-32	TCPH

Register R3

Bit	D7	D6	D5	D4	D3	D2	D1	D0
Name	reserved	reserved	STVP3	STVP2	STVP1	STVP0	FRAD1	FRAD0
Default	-	-	0	0	0	0	0	0

Register R3 setting

STVP3	STVP2	STVP1	STVP0	STV position adjust	Unit
0	0	0	0	0	T _H
0	0	0	1	+1	T _H
0	0	1	0	+2	T _H
0	0	1	1	+3	T _H
0	1	0	0	+4	T _H
0	1	0	1	+5	T _H
0	1	1	0	+6	T _H
0	1	1	1	+7	T _H
1	0	0	0	-1	T _H
1	0	0	1	-2	T _H
1	0	1	0	-3	T _H
1	0	1	1	-4	T _H
1	1	0	0	-5	T _H
1	1	0	1	-6	T _H
1	1	1	0	-7	T _H
1	1	1	1	-8	T _H

Adjust first line position by line

FRAD[1:0]:Odd frame or Even frame advance control

FRAD1	FRAD0	Advance Frame	Notes
0	0	reserved	reserved
0	1	reserved	reserved
1	0	Even Frame	Odd frame Tstv=STVP setting + 1H
1	1	Reserve	Reserve

Odd frame or Even frame Advance control

Register R4

Bit	D7	D6	D5	D4	D3	D2	D1	D0
Name	reserved	reserved	reserved	reserved	VS_POL	HS_POL	NPC_SET	NPC_IN
Default	-	-	-	-	0	0	0	1

Register R4 setting

VS_POL: VS polarity setting.

VS_POL=L, negative polarity.

VS_POL=H, positive polarity.

Note: Please set the VS_POL=H when CCIR601 mode for video decoder SAA7114.
(Please refer the input timing of the "13-4) Data input format for CCIR601 Mode")

HS_POL: HS polarity setting.

HS_POL=L, negative polarity.

HS_POL=H, positive polarity.

NPC_SET: Set the NTSC/PAL auto detection or define by NPC_IN.

NPC_SET=L, auto detection.

NPC_SET=H, define by NPC_IN.

NPC_IN: Define the NTSC/PAL mode by SPI.

NPC_IN=L, PAL.

NPC_IN=H, NTSC.

Register R5

Bit	D7	D6	D5	D4	D3	D2	D1	D0
Name	AUTO_DP	SISP_ON	A_TIME1	A_TIME0	B_TIME2	B_TIME2	B_TIME0	reserved
Default	1	0	0	1	0	1	0	-

Register R5 setting

AUTO_DP: When power on, select blank image display time decided by A_TIME (bit 5, 4) or DISP_ON (bit 6).

AUTO_DP ="L", Blank image display time decided by DISP_ON (bit 6).

AUTO_DP ="H", Blank image display time decided by A_TIME (bit 5, 4).

DISP_ON: When AUTO_DP (bit 7) ="L", and DISP_ON ="H", blank image display off, then display normal image.

A_TIME [1:0]: When AUTO_DP(bit 7) ="H". the blank image display time is decided by A_TIME

00: blank image display time is 8 VS time

01: blank image display time is 16 VS time

10: blank image display time is 32 VS time

11: blank image display time is 64 VS time

B_TIME [2:0]: When into STB mode. the blank image display time is decided by B_TIME.

000: blank image display time is 3 VS time.

001: blank image display time is 4 VS time.

010: blank image display time is 5 VS time.

011: blank image display time is 6 VS time.

100: blank image display time is 7 VS time.

101: blank image display time is 8 VS time.

110: blank image display time is 9 VS time.

111: blank image display time is 10 VS time.

10-2) Power ON/OFF sequence

To prevent the device damage from latch up, the power ON/OFF sequence shown below must be followed.

- Power ON: VCC1, GND → VDDA, VSSA → V1 to V10
- Power OFF: V1 to V10 → VDDA, VSSA → VCC1, GND

10-3) Power ON Control

Source drive has a power ON sequence control function. There are two kinds of the mode. One is auto mode, and another is manual mode.

Auto Mode: When power is ON, blank data is outputted for 16-frames (default value) first, from the falling edge of the following VS signal. The blank data would be gray level 255 for normally white panel.

It can be defined in register R5 A_TIME1 (bit 5) and A TIME0 (bit 4) when AUTO_DP (bit 7) = "H"

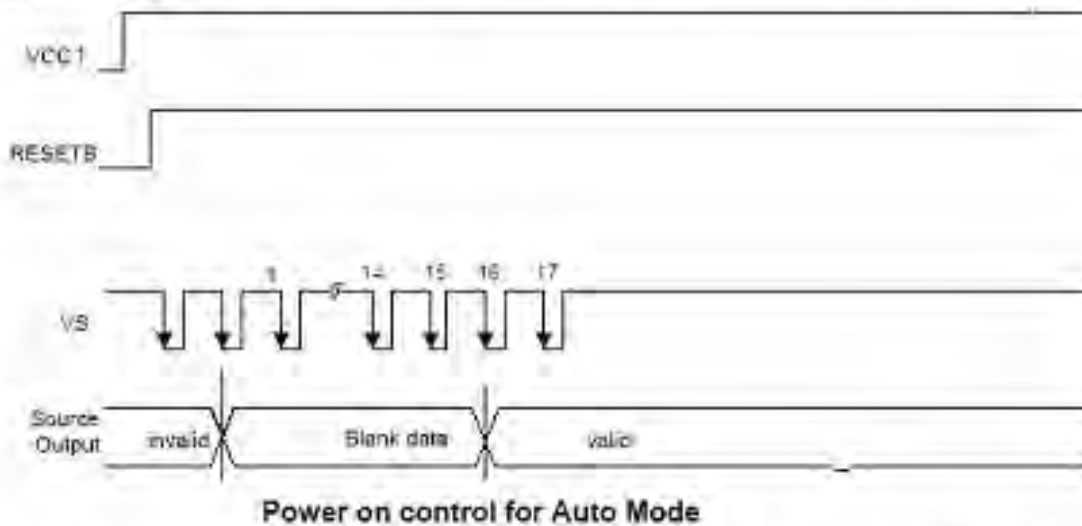

Manual Mode: When power is ON, you should set the register R5 AUTO_DP (bit 7) = "L" to stay at the manual mode. Blank data is outputted until the DISP_ON (bit 6) = H then display the normal image.

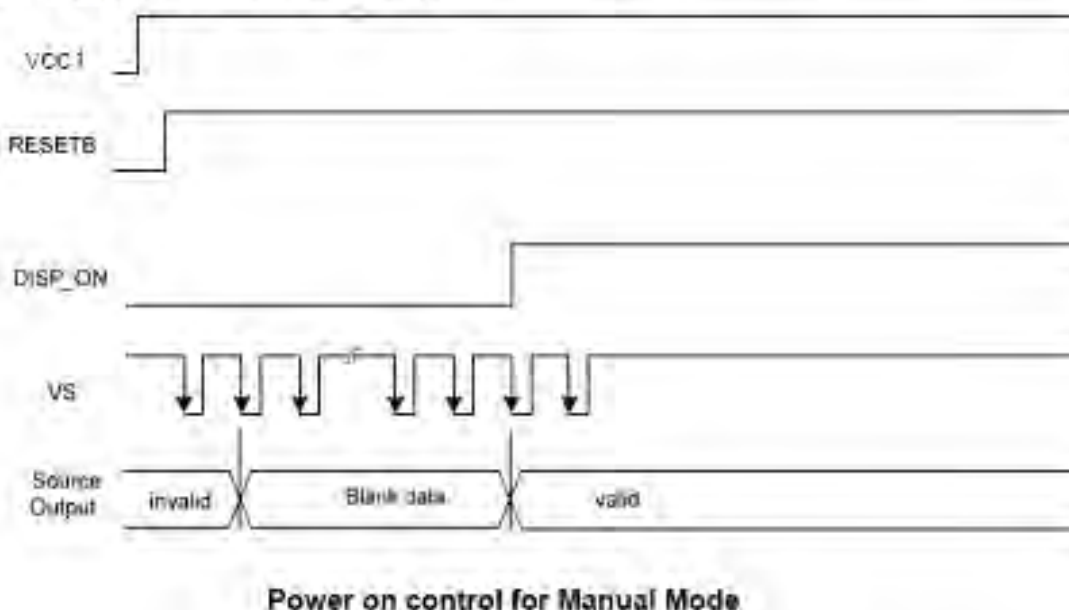

10-4) Standby ON/OFF Control

Source drive has a standby ON/OFF sequence control function. When STB pin is "L", blank data is outputted for 5-frames (default value) first, from the falling edge of the following VSYNC signal. The blank data would be gray level 255 for normally white panel. It can be defined in register R5 B_TIME[2:0] to adjust the frame number of the blank data.

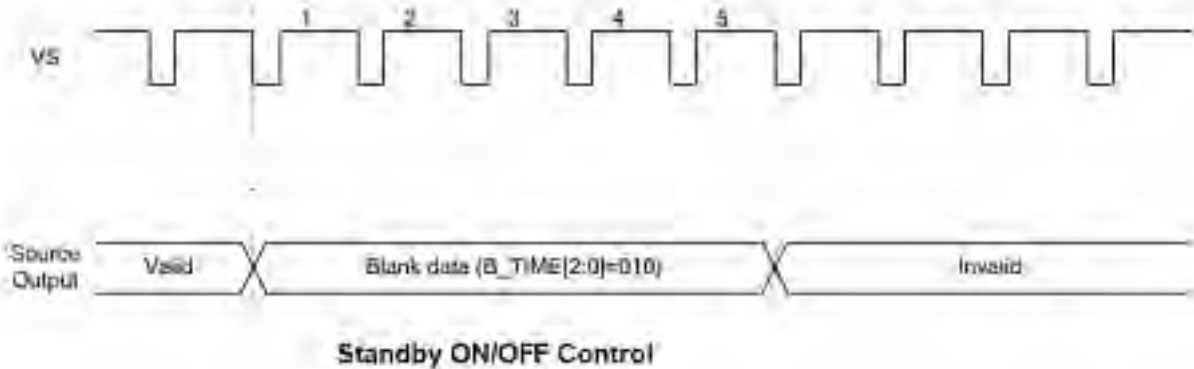

10-5) Reset when power on

Source drive is internally initialized by the global reset signal, RESETB. The reset input must be held for at least 1ms after power is stable.

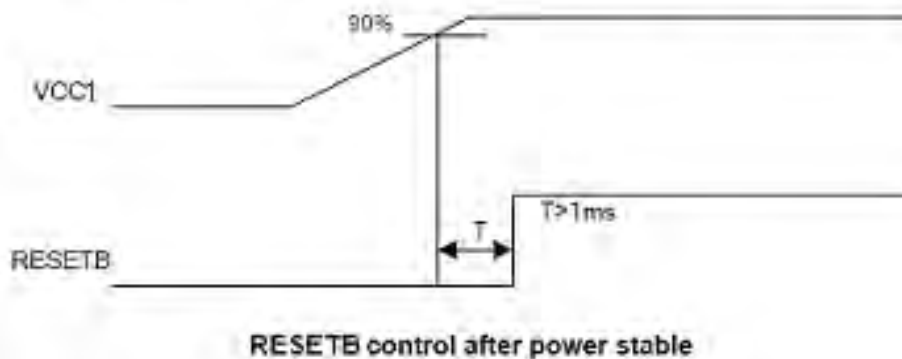

11.AC Characteristics
11-1) SPI timing characteristics

PARAMETER	Symbol	Spec.			Unit
		Min.	Typ.	Max.	
SPCK period	T_{CK}	60	-	-	ns
SPCK high width	T_{CKH}	30	-	-	ns
SPCK low width	T_{CKL}	30	-	-	ns
Data setup time	T_{SUI}	12	-	-	ns
Data hold time	T_{HDI}	12	-	-	ns
SPENA to SPCK setup time	T_{CS}	20	-	-	ns
SPENA to SPDA hold time	T_{CE}	20	-	-	ns
SPENA high pulse width	T_{CD}	50	-	-	ns

11-2) Digital Parallel RGB interface

PARAMETER	Symbol	Spec.			Unit
		Min.	Typ.	Max.	
CLK frequency	F_{CPH}	-	6.43	-	MHZ
CLK period	T_{CPH}	-	155.62	-	ns
CLK pulse duty	T_{CWH}	40	50	60	%
HS period	T_H	-	408	-	T_{CPH}
HS pulse width	T_{WH}	5	30	-	T_{CPH}
HS-first horizontal data time	T_{HS}	36	68	99	T_{CPH}
DEN pulse width	T_{EF}	-	320	-	T_{CPH}
VS pulse width	T_{WV}	1	3	5	T_H
VS-DEN time	NTSC T_{STV}	-	18	-	T_H
	PAL T_{STV}	-	26	-	T_H
VS period	NTSC T_V	-	262.5 / 262	-	T_H
	PAL T_V	-	312.5 / 312	-	T_H

Note: When SYNC mode is used, 1st data start from 204th CLK after HS falling (when $STHD[5:0]=000000$)

PARAMETER	Symbol	Spec.			Unit
		Min.	Typ.	Max.	
OEV pulse width	T_{OEV}	-	26	-	T_{CPH}
CKV pulse width	T_{CKV}	-	24	-	T_{CPH}
HS-CKV time	T_1	-	16	-	T_{CPH}
HS-OEV time	T_2	-	8	-	T_{CPH}
HS-POL time	T_3	-	25	-	T_{CPH}
STV setup time	T_{SUV}	-	10	-	T_{CPH}
STV pulse width	T_{WSTV}	-	1	-	T_H

12-3) Data input format for RGB Mode

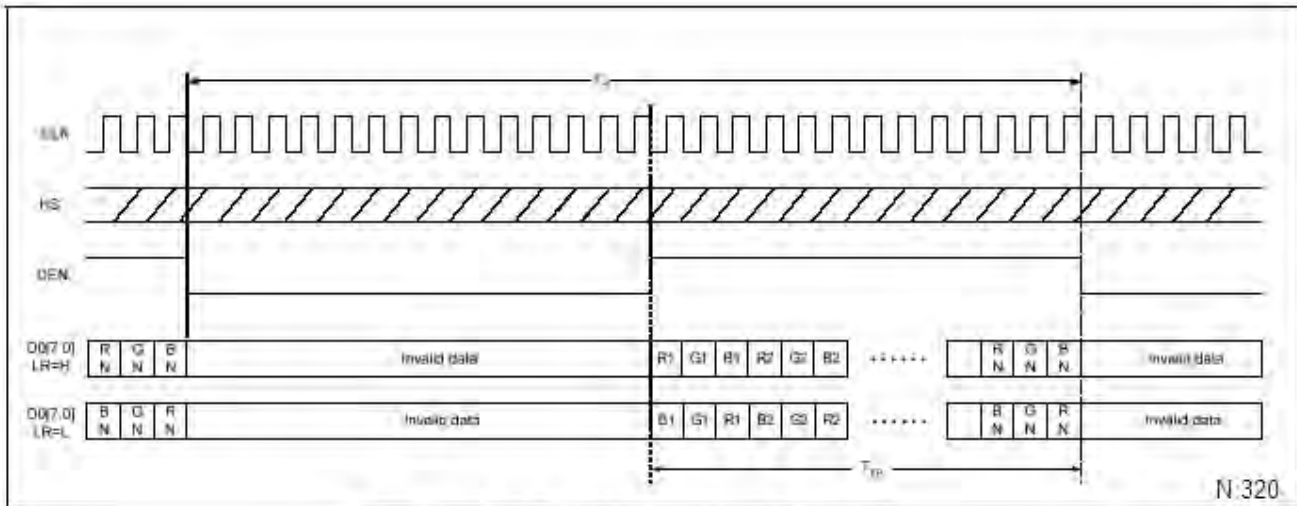

Parallel RGB Horizontal Data Format

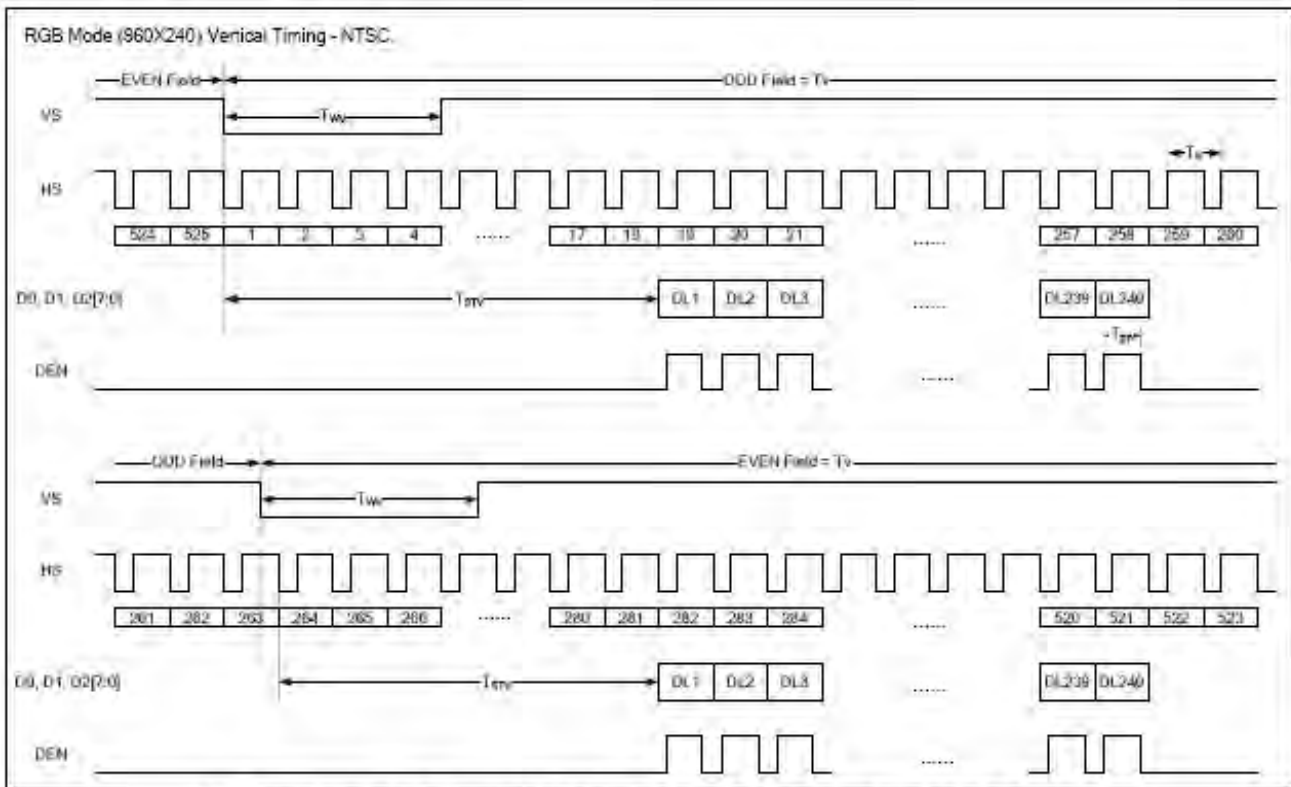

Digital RGB NTSC mode Vertical Data Format for 262.5T_H

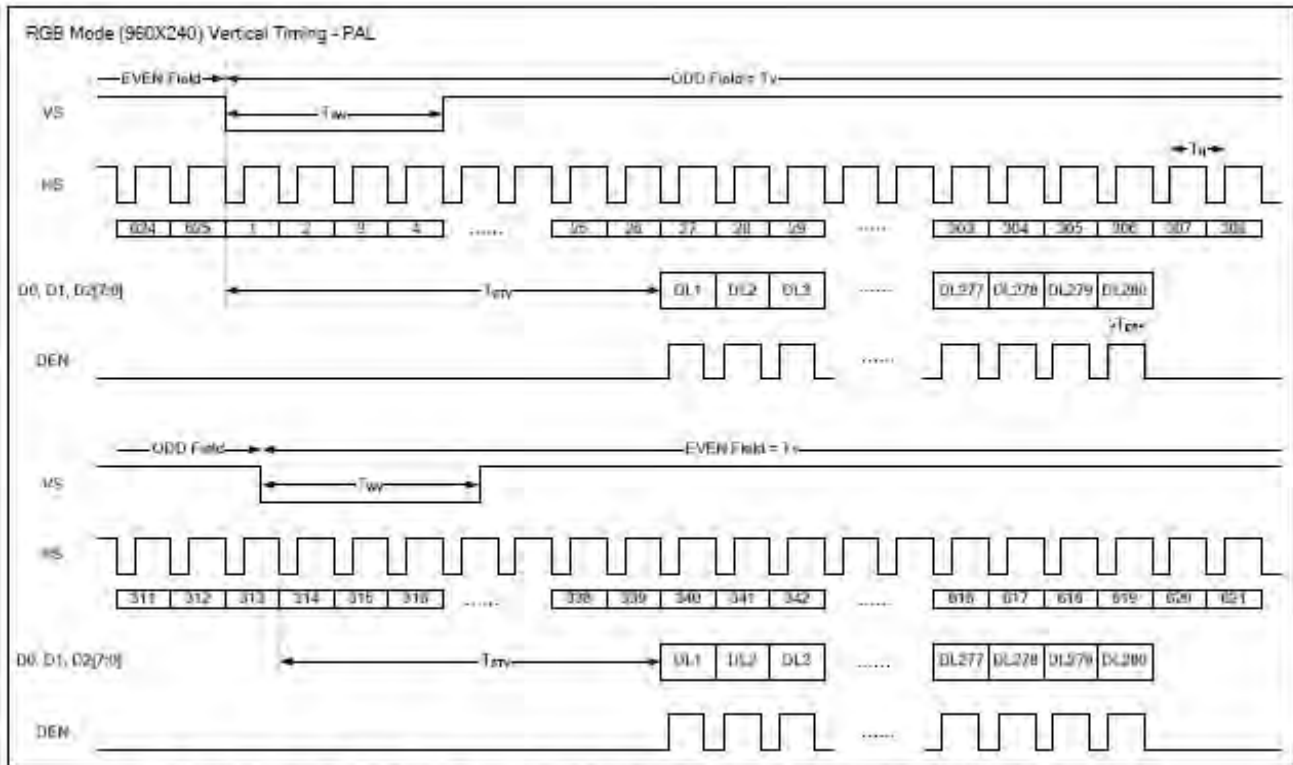
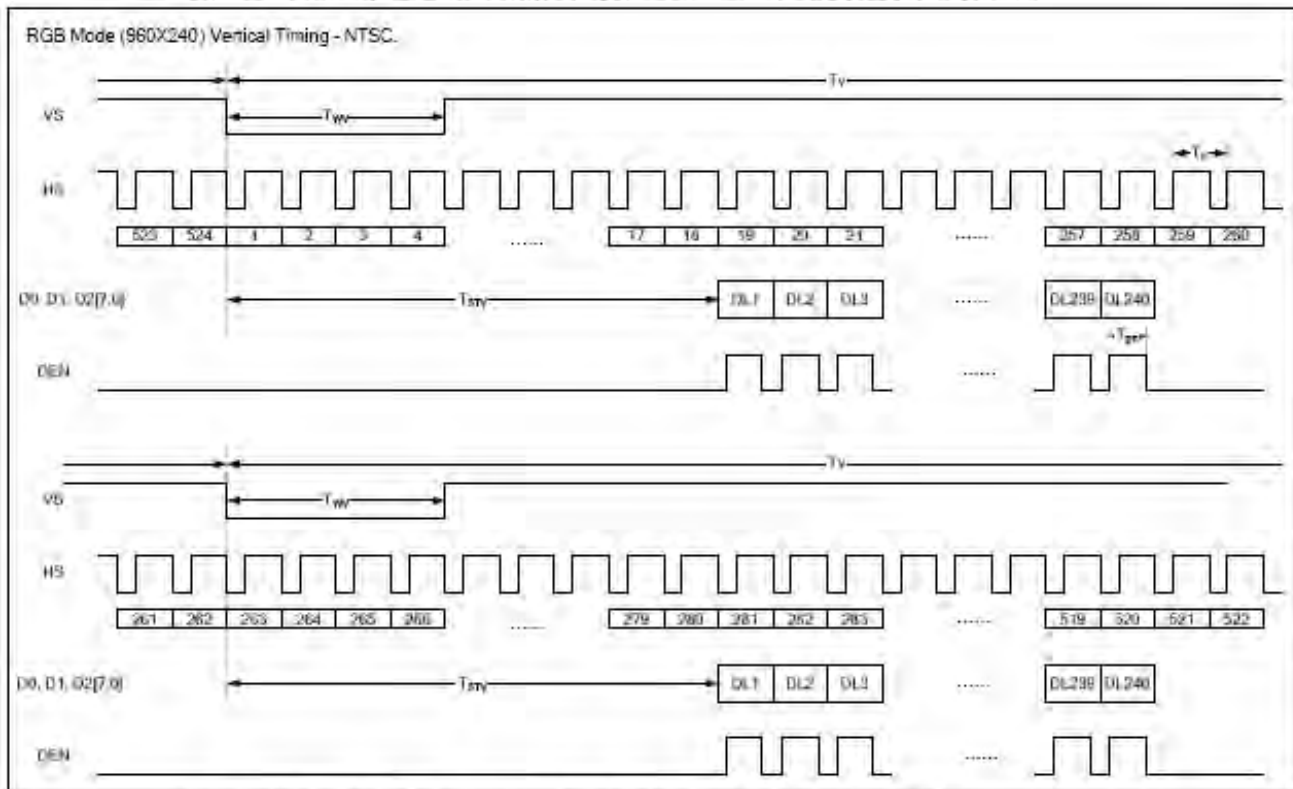
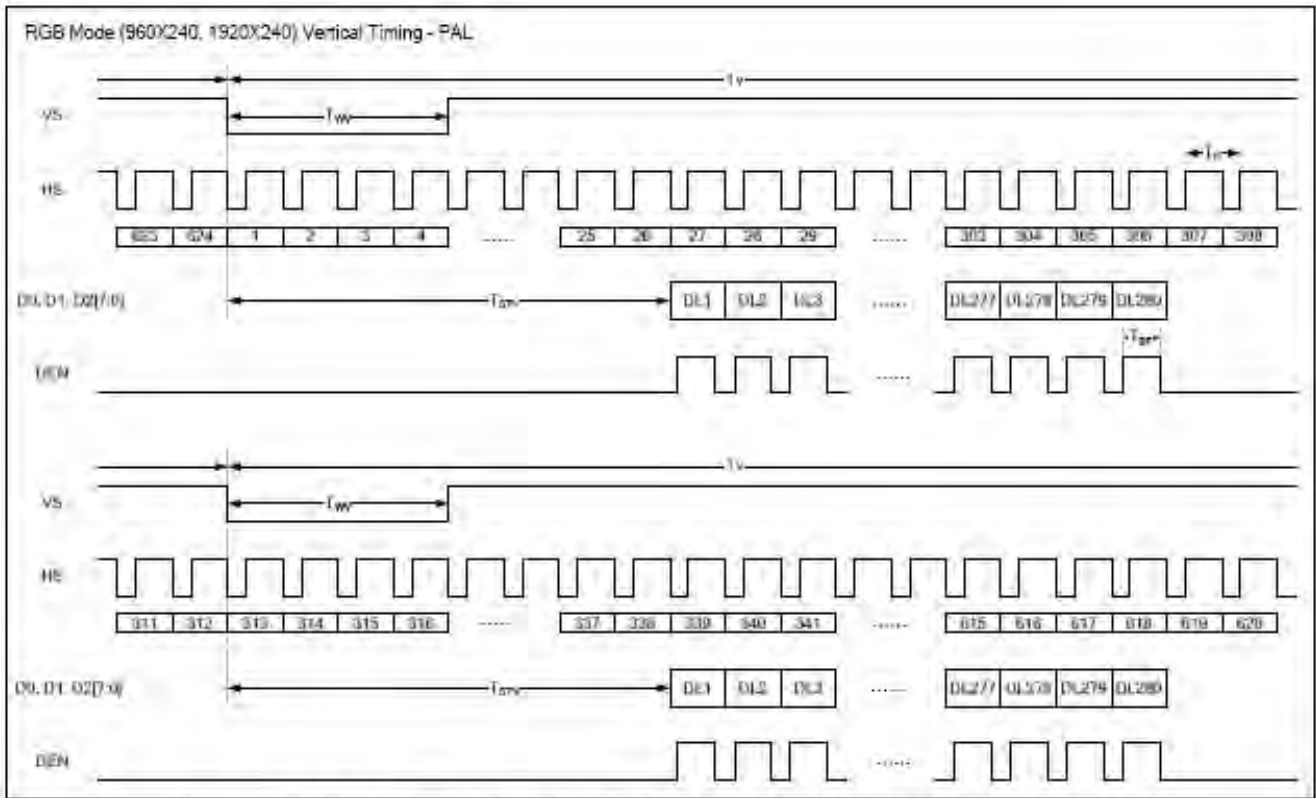

Fig0 Digital RGB PAL mode Vertical Data Format for 312.5T_H



Digital RGB NTSC mode Vertical Data Format for 262T_H



Digital RGB PAL mode Vertical Data Format for 312T_H

12-4) The HS & VS timing of the ODD/EVEN field

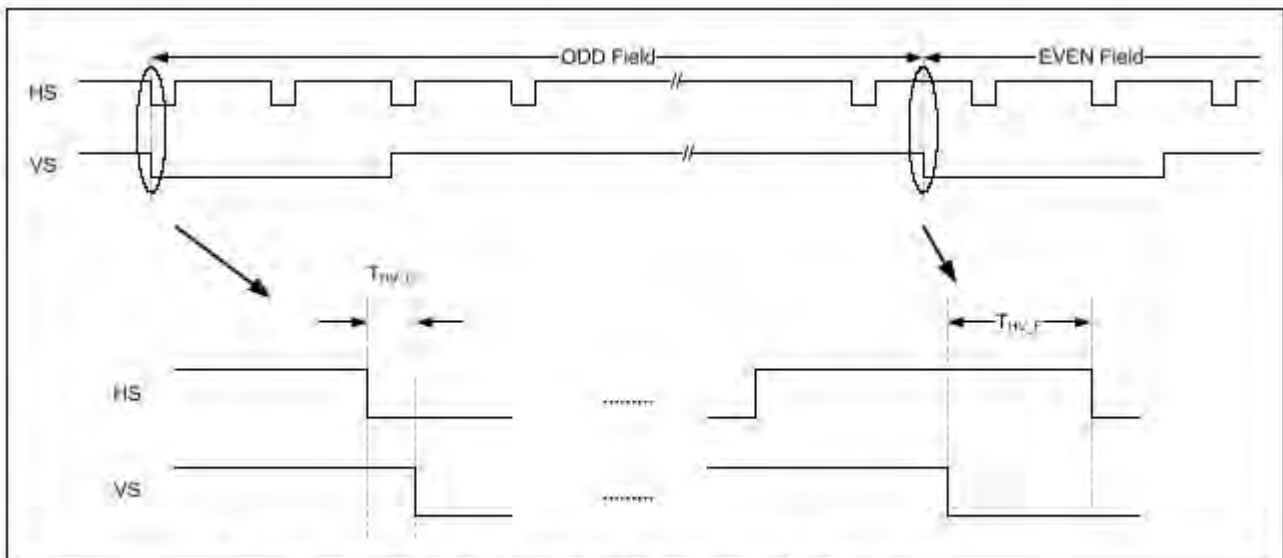

Define the HSYNC to VSYNC timing for RGB mode

13. Power On Sequence

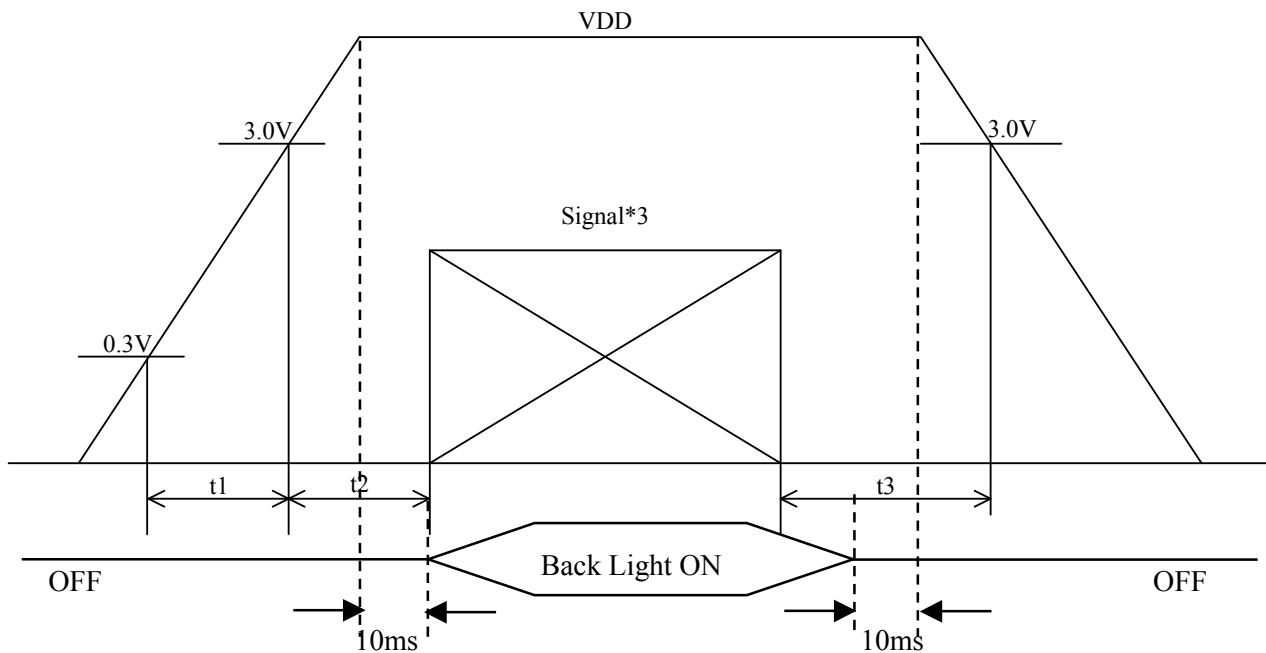

1. $0 < t1 \leq 20\text{ms}$
2. $0 < t2 \leq 50\text{ms}$
3. $0 < t3 \leq 1\text{s}$

14. Optical Characteristics

14-1) Specification:

Ta = 25°C

Parameter	Symbol	Condition	MIN.	TYP.	MAX.	Unit	Remarks
Viewing Angle	Horizontal	$\theta 21, \theta 22$	75	80	---	deg	Note 14-1
	Vertical	$\theta 12$	45	50	---	deg	
		$\theta 11$	55	60	---	deg	
Contrast Ratio	CR	At optimized Viewing angle	200	400	---		Note 14-2
Luminance	L	$\theta = 0^\circ$	300	350	---	cd/m ²	
White Chromaticity	x	$\theta = 0^\circ$	0.26	0.30	0.34		
	y	$\theta = 0^\circ$	0.29	0.33	0.37		
Response time	Rise	Tr	---	15	30	ms	Note 14-3
	Fall	Tf	---	25	50	ms	
Uniformity	U	-	75	80	---	%	Note 14-5
Cross Talk Ratio	CTK	-	---	---	3.5	%	Note 14-6
LED Life Time		+25°C	20000	30000	---	hrs	Note 14-4

Note 14-1 : The definitions of viewing angles

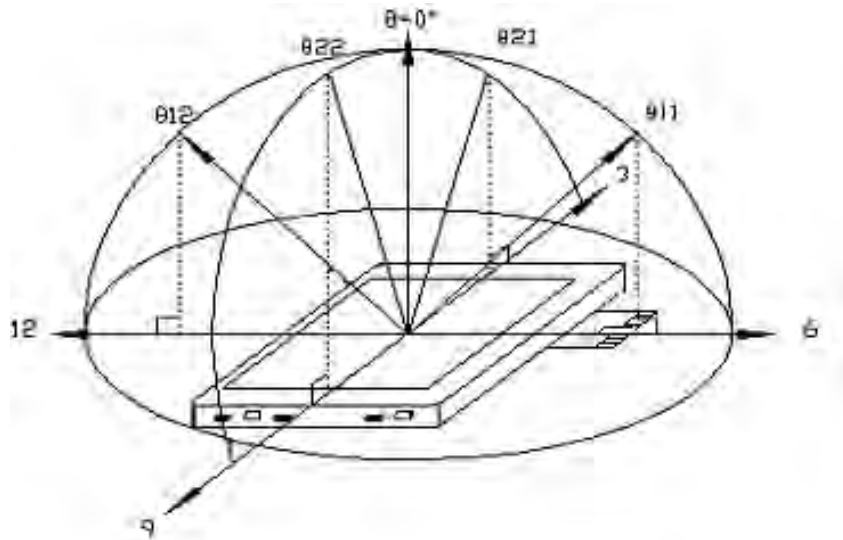

Note 14-2 : $CR = \frac{\text{Luminance when Testing point is White}}{\text{Luminance when Testing point is Black}}$

Contrast Ratio is measured in optimum common electrode voltage.

Note 14-3 : The definition of response time :

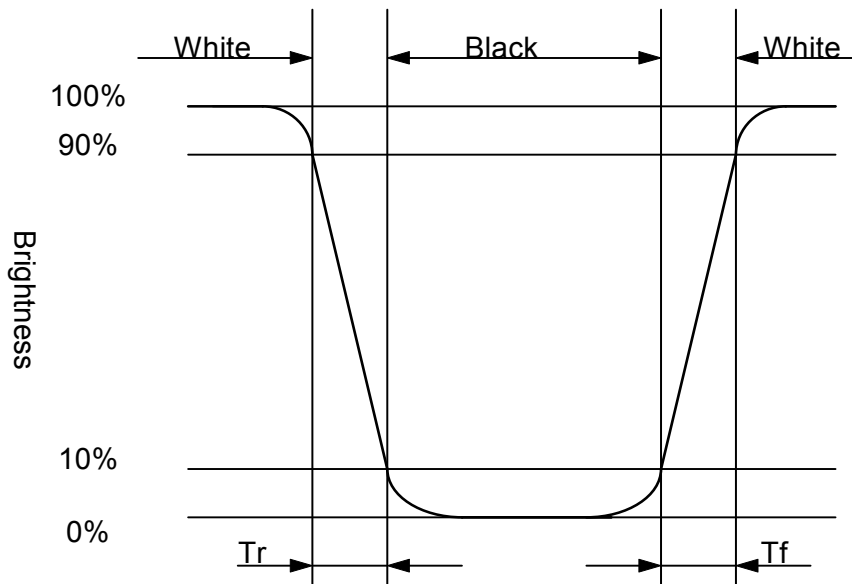

Note 14-4 : The “LED Life time “ is defined as the module brightness decrease to 50% original Brightness that the ambient temperature is 25°C and $I_{LED} = 20mA$

Note 14-5: The uniformity of LCD is defined as

$$U = \frac{\text{The Minimum Brightness of the 9 testing Points}}{\text{The Maximum Brightness of the 9 testing Points}}$$

Luminance meter : BM-5A or BM-7 fast(TOPCON)

Measurement distance : 500 mm +/- 50 mm

Ambient illumination : < 1 Lux

Measuring direction : Perpendicular to the surface of module

The test pattern is white (Gray Level 63).

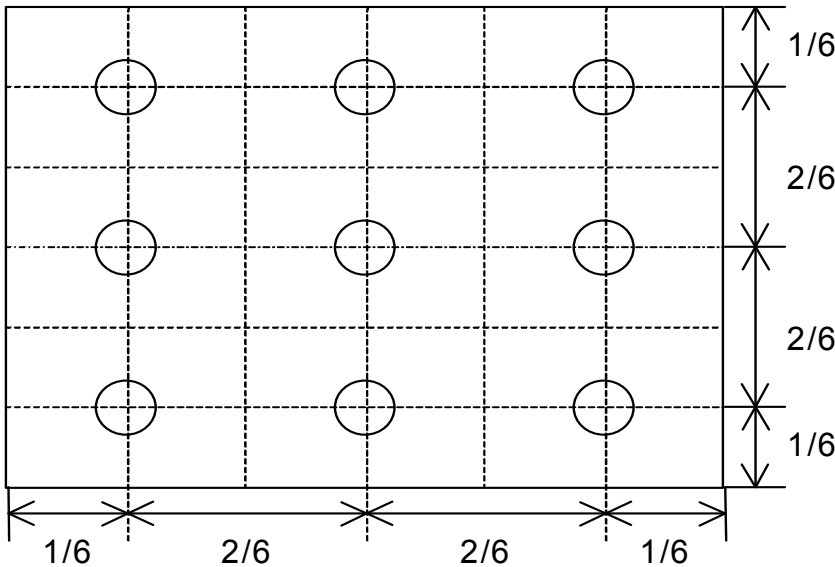

Note 14-6: Cross Talk (CTK) = $\frac{|YA-YB|}{YA} \times 100\%$

YA: Brightness of Pattern A

YB: Brightness of Pattern B

Luminance meter : BM 5A (TOPCON)

Measurement distance : 500 mm +/- 50 mm

Ambient illumination : < 1 Lux

Measuring direction : Perpendicular to the surface of module

Pattern A
(Gray Level 31)

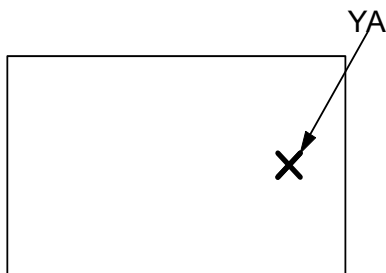

Pattern B
(Gray Level 31, central black box exclusive)

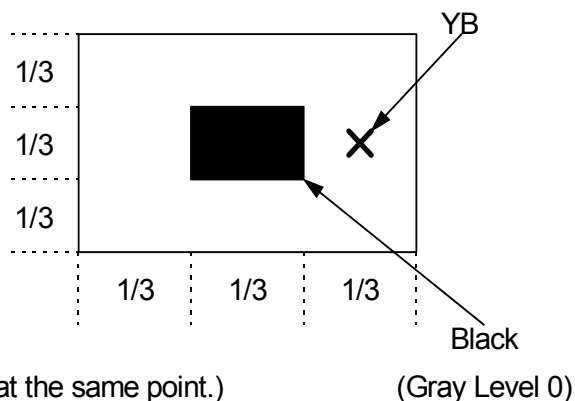

X: Measuring Point (A and B are at the same point.)

(Gray Level 0)

15. Handling Cautions

15-1) Mounting of module

- A) Please power off the module when you connect the input/output connector.
- B) Polarizer which is made of soft material and susceptible to flaw must be handled carefully.
- C) Protective film (Laminator) is applied on surface to protect it against scratches and dirt.
- D) Please following the tear off direction as figure15-1 to remove the protective film as slowly as possible, so that electrostatic charge can be minimized.

15-2) Precautions in mounting

- A) When metal part of the TFT-LCD module (shielding lid and rear case) is soiled, wipe it with soft dry cloth.
- B) Wipe off water drops or finger grease immediately. Long contact with water may cause discoloration or spots.
- C) TFT-LCD module uses glass which breaks or cracks easily if dropped or bumped on hard surface. Please handle with care.
- D) Since CMOS LSI is used in the module. So take care of static electricity and earth yourself when handling.

15-3) Adjusting module

- A) Adjusting volumes on the rear face of the module have been set optimally before shipment.
- B) Therefore, do not change any adjusted values. If adjusted values are changed, the specifications described may not be satisfied.

15-4) Others

- A) Do not expose the module to direct sunlight or intensive ultraviolet rays for many hours.
- B) Store the module at a room temperature place.
- C) The voltage of beginning electric discharge may over the normal voltage because of leakage current from approach conductor by to draw lump read lead line around.
- D) If LCD panel breaks, it is possibly that the liquid crystal escapes from the panel. Avoid putting it into eyes or mouth. When liquid crystal sticks on hands, clothes or feet. Wash it out immediately with soap.
- E) Observe all other precautionary requirements in handling general electronic components.
- F) Please adjust the voltage of common electrode as material of attachment by 1 module.

15-5) Polarizer mark

The polarizer mark is to describe the direction of view angle film how to mach up with the rubbing direction.

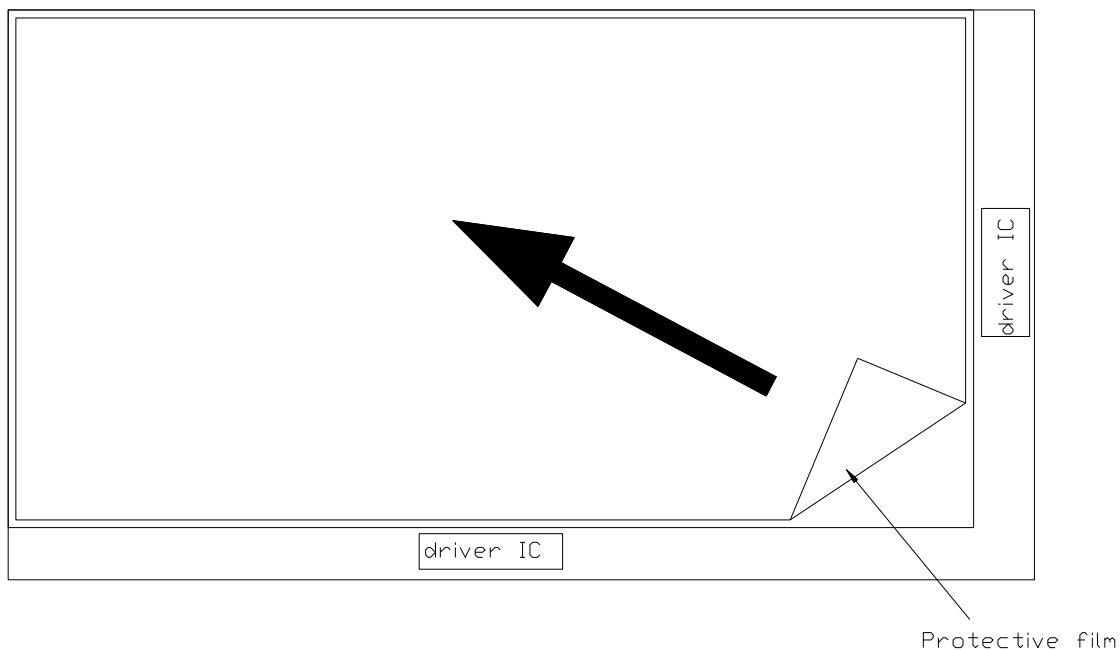

Figure 15 -1 the way to peel off protective film

16. Reliability Test

No	Test Item	Test Condition
1	High Temperature Storage Test	Ta = +80°C, 240 hrs
2	Low Temperature Storage Test	Ta = -40°C, 240 hrs
3	High Temperature Operation Test	Ta = +80°C, 240 hrs
4	Low Temperature Operation Test	Ta = -30°C, 240 hrs
5	High Temperature & High Humidity Operation Test	Ta = +60°C, 90%RH, 240 hrs
6	Thermal Cycling Test (non-operating)	-30°C → +80°C, 200 Cycles, 30 min 30 min
7	Vibration Test (non-operating)	Frequency: 10~55Hz Amplitude: 1.5mm Sweep time: 11 mins Test Period: 6 Cycles for each direction of X,Y,Z
8	Shock Test (non-operating)	100G, 6ms Direction : ±X, ±Y, ±Z Cycle : 3 times
9	Electrostatic Discharge Test (non-operating)	200pF, 0Ω ±200V 1 time / each terminal

Ta: ambient temperature

Note : The protective film must be removed before temperature test.

[Criteria]

In the standard conditions, there is not display function NG issue occurred. (including : line defect ,no image).All the cosmetic specification is judged before the reliability stress.

17. Block Diagram

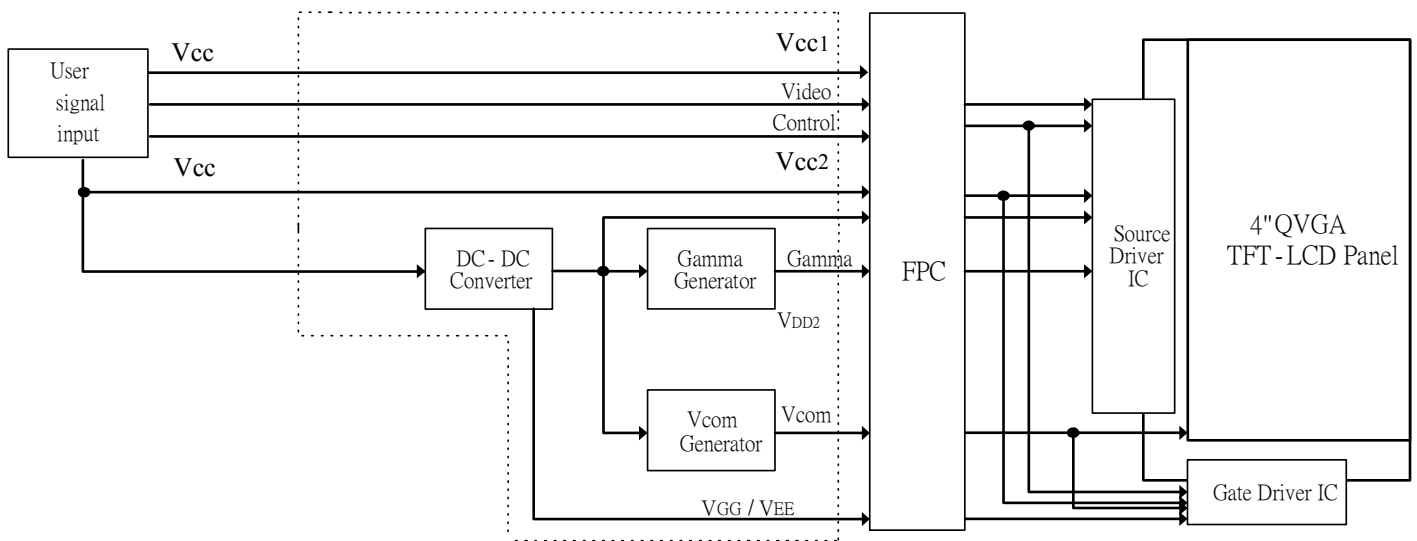

18. Packing

ZONE	REV.	DOCUMENT NO.	DESCRIPTION	DATE	REV. BY
------	------	--------------	-------------	------	---------

NOTE:

1. One layer include: 1 piece of cushion sheet, 9 pcs module & 1 piece of tray.
2. Q'TY: 72 pcs module/carton.
3. Dimension: 455*375*190mm
4. Weight: 6 KG
5. Tray 需180°交叉堆疊，堆疊後可從側邊檢視圓弧防呆方向是否正確

ITEM	PART NO.	DESCRIPTION	QTY	REMARK
6	50-0100091	CARTON INTERNAL	1	
5	50-0500041	摺口袋450*380*700mm	1	抗靜電
4		PD040QX1	72	
3	50-0200106	EPE CUSHION SHEET	8	抗靜電
2	50-0301861	TRAY	9	抗靜電
1	50-0300491	EPE FOAM	2	

MTL.SPEC.		UNSPECIFIED TOL'S		REMARK	
		ANGLE			
		ROUGHNESS			
APPROVE	Frank Shin	'07.09.18	SCALE	UNIT	SHEET
CHECK	Frank Shin	'07.09.18			1 OF 1
DESIGN	Patrick Lin	'07.09.18	MTL.NO.		DWG.NO.
					REV. 02
					A4 SIZE

元太科技股份有限公司
Prime View International Co.,ltd.

DWG.TITLE

PD040QX1 PACKING