

# ***TFT-Display Datenblatt***

Modell PD050VX6

## **Kurzdaten**

Hersteller	E Ink / PrimeView
Diagonale	5,0" / 12,7cm
Format	4:3
Auflösung	640x480
Backlight	LED/ 450cd/m <sup>2</sup>
Interface	RGB
Touchscreen	nein
Temperatur	-30...+80°C (Betrieb)

**Version :4.0**



Inselkammerstr. 10  
82008 Unterhaching  
Tel: +49 89 614 503 40  
www.hy-line.de/computer

**TECHNICAL SPECIFICATION**  
**MODEL NO : PD050VX6**

The content of this information is subject to be changed without notice.  
Please contact E Ink or its agent for further information.

Customer's Confirmation

Customer \_\_\_\_\_

Date \_\_\_\_\_

By \_\_\_\_\_

E Ink's Confirmation

Confirmed By \_\_\_\_\_

Prepared By \_\_\_\_\_

## Revision History

Rev.	Issued Date	Revised
0.1	Sep.12, 2006	Preliminary
0.2	Nov 24,2006	Modify Page4 4.Mechanical Drawing of TFT-LCD Module Add Page19 13. Optical Characteristics
1.0	May 7, 2007	New
2.0	August.11.2008	Add Page 24 14.Handling Cautions d) items of 14-1
3.0	August.18.2009	Modify Page 26 16.Packing Diagram
4.0	August.18.2011	Modify 13. Optical Characteristics : Viewing Angle & Contrast Ratio

# TECHNICAL SPECIFICATION

## CONTENTS

<b>NO.</b>	<b>ITEM</b>	<b>PAGE</b>
-	Cover	1
-	Revision History	2
-	Contents	3
1	Application	4
2	Features	4
3	Mechanical Specifications	4
4	Mechanical Drawing of TFT-LCD module	5
5	Input / Output Terminals	7
6	Absolute Maximum Ratings	11
7	Electrical Characteristics	11
8	Pixel Arrangement	12
9	Display Color and Gray Scale Reference	13
10	Block Diagram	14
11	Interface Timing	15
12	Power On Sequence	20
13	Optical Characteristics	20
14	Handling Cautions	24
15	Reliability Test	25
16	Packing Diagram	26

## 1.Application

PD050VX6 module applies to computer peripheral, industrial meter, car TV, image communication and multi-media, which requires high quality flat panel display. If you must use in severe reliability environment, please don't extend over PVI's reliability test conditions. PVI's reliability test conditions.

If you use PD050VX6, Prime View advises your systems use PVI's timing controller IC (PVI-2003A) which will generate proper timing signals to control it.

## 2.Features

- . VGA (640\*480 pixels) resolution
- . Amorphous silicon TFT LCD panel with LED B/L
- . Pixel in stripe configuration

## 3.Mechanical Specifications

Parameter	Specifications	Unit
Screen Size	5.0(diagonal)	inch
Display Format	640×(R, G, B)×480	dot
Display Colors	262K	
Active Area	101.76(H)×74.88(V)	mm
Pixel Pitch	0.159(H)×0.156(V)	mm
Pixel Configuration	Stripe	
Outline Dimension	119.3(H)×91.4(V)×7.9(D)	mm
Weight	120±10	g
Surface treatment	Anti-glare and SWV film	
Back-light	24-LED	
Display mode	Normally white	
Gray scale inversion direction	6 (ref to Note 13-1)	o'clock

4.Mechanical Drawing of TFT-LCD Module

Outline Drawing : Front View (unit mm)

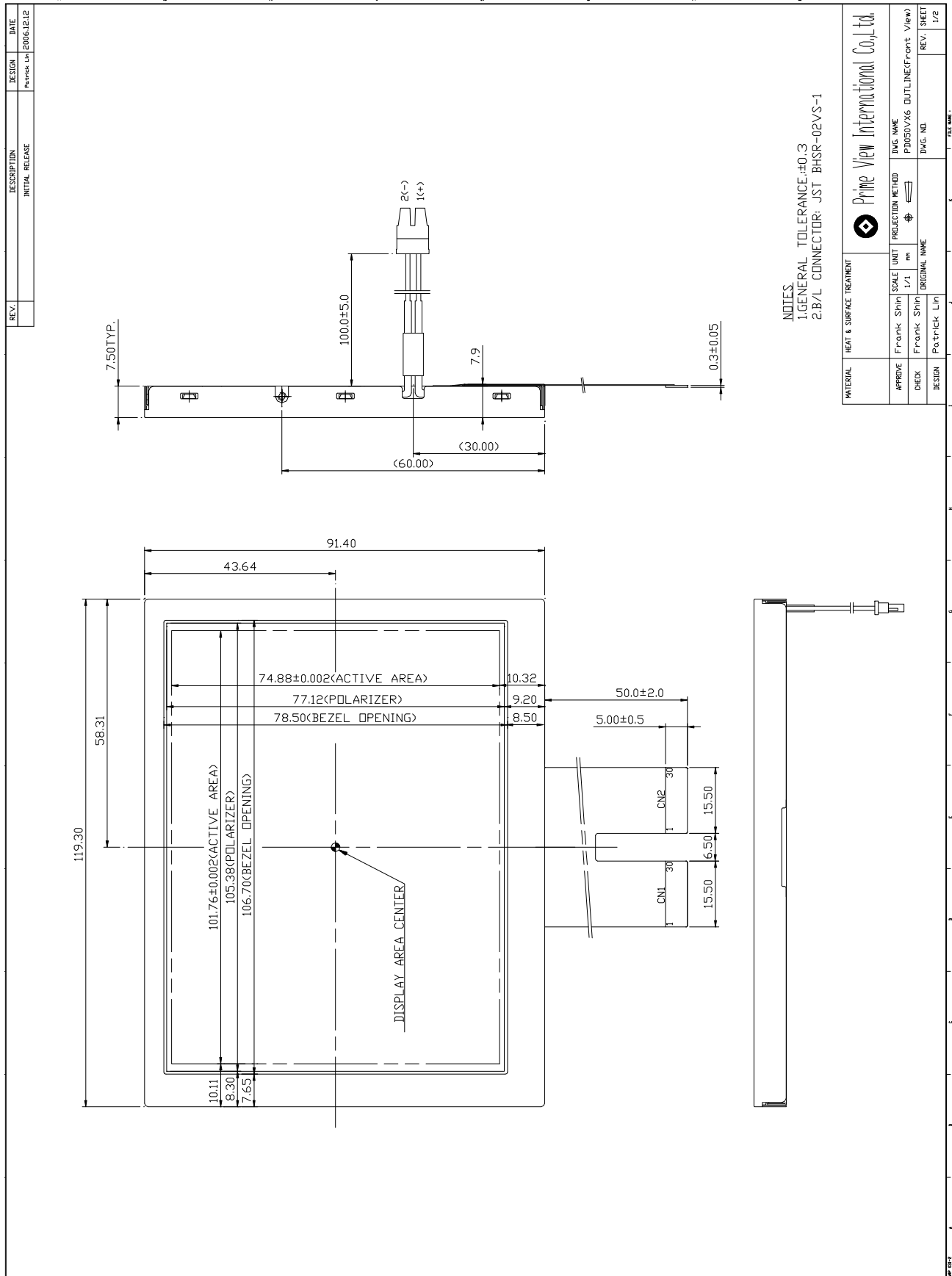

Outline Drawing : Rear View (unit mm)

REV.	DESCRIPTION	DESIGN	DATE
	INITIAL RELEASE	Patrick Lin	2006.12.12

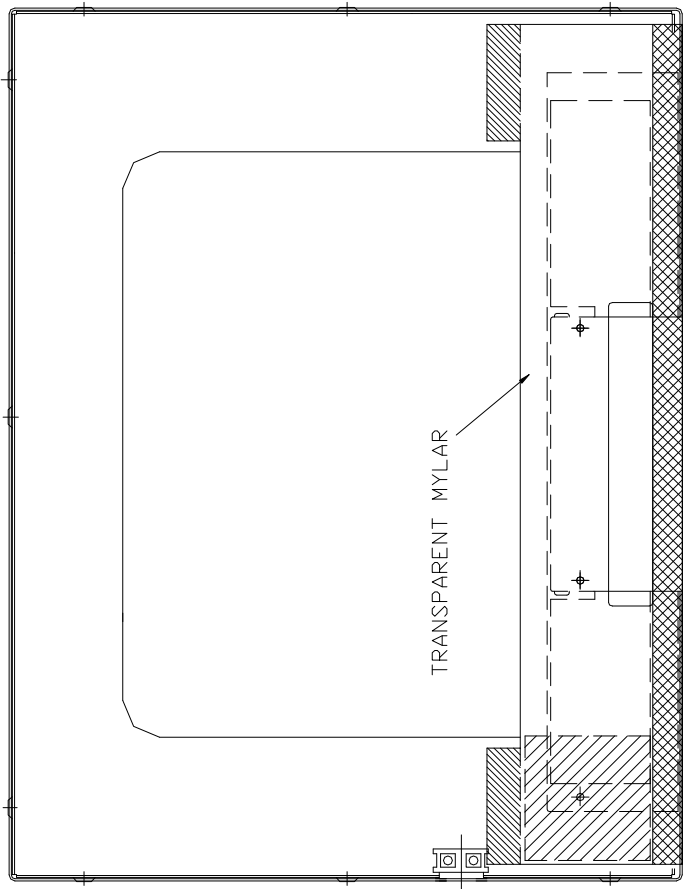

NOTES  
 1.GENERAL TOLERANCE:±0.3  
 2.B/L CONNECTOR: JST BHSR-02VS-1

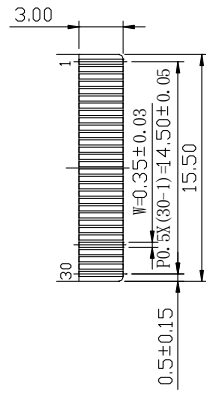

DETAIL \*A\*  
(S: 2/1,2PLS)

MATERIAL	HEAT & SURFACE TREATMENT	Prime View International Co., Ltd	
APPROVE	Frank Shin	SCALE UNIT	PROJECTION METHOD
CHECK	Frank Shin	1/1	m
DESIGN	Patrick Lin	ORIGINAL NAME	
		DWG. NAME	PD050VX6 OUTLINE(Back View)
		DWG. NO.	
		REV.	SHEET
			2/2

## 5. Input / Output Terminals

## 5-1) TFT-LCD Panel Driving

FPC Down Connect, 30 Pins, Pitch: 0.5 mm

CN 1

Pin No.	Symbol	I/O	Function	Remark
1	DIO1	I/O	Horizontal Start Pulse Signal Input or Output	Note 5-6
2	VSS1	I	Ground	
3	VDD1	I	Power Supply for Source	
4	CLK	I	Horizontal Shift Clock	
5	VSS1	I	Ground	
6	R/L	I	Right / Left Selection	Note 5-6
7	R0	I	Red Data (LSB)	
8	R1	I	Red Data	
9	R2	I	Red Data	
10	R3	I	Red Data	
11	R4	I	Red Data	
12	R5	I	Red Data (MSB)	
13	VSS1	I	Ground	
14	G0	I	Green Data (LSB)	
15	G1	I	Green Data	
16	G2	I	Green Data	
17	G3	I	Green Data	
18	G4	I	Green Data	
19	G5	I	Green Data (MSB)	
20	VSS1	I	Ground	
21	B0	I	Blue Data (LSB)	
22	B1	I	Blue Data	
23	B2	I	Blue Data	
24	B3	I	Blue Data	
25	B4	I	Blue Data	
26	B5	I	Blue Data (MSB)	
27	LD	I	Load output signal	Note 5-7
28	REV	I	Data invert control	Note 5-8
29	POL	I	Polarity selection	Note 5-9
30	DIO2	I/O	Horizontal Start Pulse Signal Input or Output	Note 5-6

CN 2

Pin No.	Symbol	I/O	Function	Remark
1	VSS2	I	Ground	
2	V1	I	Gamma Voltage 1	Note 5-10
3	V2	I	Gamma Voltage 2	Note 5-10
4	V3	I	Gamma Voltage 3	Note 5-10
5	V4	I	Gamma Voltage 4	Note 5-10
6	V5	I	Gamma Voltage 5	Note 5-10
7	V6	I	Gamma Voltage 6	Note 5-10
8	V7	I	Gamma Voltage 7	Note 5-10
9	VSS2	I	Ground	
10	V8	I	Gamma Voltage 8	Note 5-10
11	V9	I	Gamma Voltage 9	Note 5-10
12	V10	I	Gamma Voltage 10	Note 5-10
13	V11	I	Gamma Voltage 11	Note 5-10
14	V12	I	Gamma Voltage 12	Note 5-10
15	V13	I	Gamma Voltage 13	Note 5-10
16	V14	I	Gamma Voltage 14	Note 5-10
17	VSS2	I	Ground	
18	VDD2	I	Voltage for analog circuit	Note 5-10
19	VCOM	I	Common Voltage	
20	XON	I	NC	
21	OE	I	Output Enable	Note 5-5
22	U/D	I	Up/Down selection	Note 5-3
23	CKV	I	Vertical Shift Clock	Note 5-4
24	STVU	I/O	Vertical Shift Pulse Signal Input or Output	Note 5-3
25	STVD	I/O	Vertical Shift Pulse Signal Input or Output	Note 5-3
26	VGG	I	Gate On Voltage	Note 5-2
27	GND	I	Ground	
28	VCC	I	Voltage for logic circuit	
29	GND	I	Ground	
30	VEE	I	Gate Off Voltage	Note 5-1

Note 5-1: Gate off voltage,  $V_{EE}=-5.5V$

Note 5-2: Gate on voltage,  $V_{GG}=17V$

Note 5-3: Select up or down shift

U/D	STVU	STVD	Shift
1	Hi-Z	Input	Down to Up
0	Input	Hi-Z	Up to Down

Note 5-4: Gate driver shift clock

Note 5-5: When OE is connected to high “1”, the driver outputs are disabled (Gate output =  $V_{EE}$ ). Under this condition, the operation of registers will not be affected.

Note 5-6: Select left or right shift

R/L	DIO1	DIO2	Shift
1	Input	Hi-Z	Left to right
0	Hi-Z	Input	Right to left

Note 5-7: Latch the polarity of outputs and switch the new data to outputs. At the rising edge (LD), latch the “POL” signal to control the polarity of the outputs.

Note 5-8: Control whether the Data R0~G5 are inverted or not. (PVI suggests connecting to GND)  
 When “REV=1”, these data will be inverted.  
 EX: “00”→”3F”, “07”→”38”, “15”→”2A”

Note 5-9: Polarity selector for dot-inversion control. Available at the rising edge of LD.  
 When POL=1: Even outputs range from V1~V7, and Odd outputs range from V8~V14;  
 When POL=0: Even outputs range from V8~V14, and Odd outputs range from V1~V7.

Note 5-10:  $V_{DD2}=7.7V$

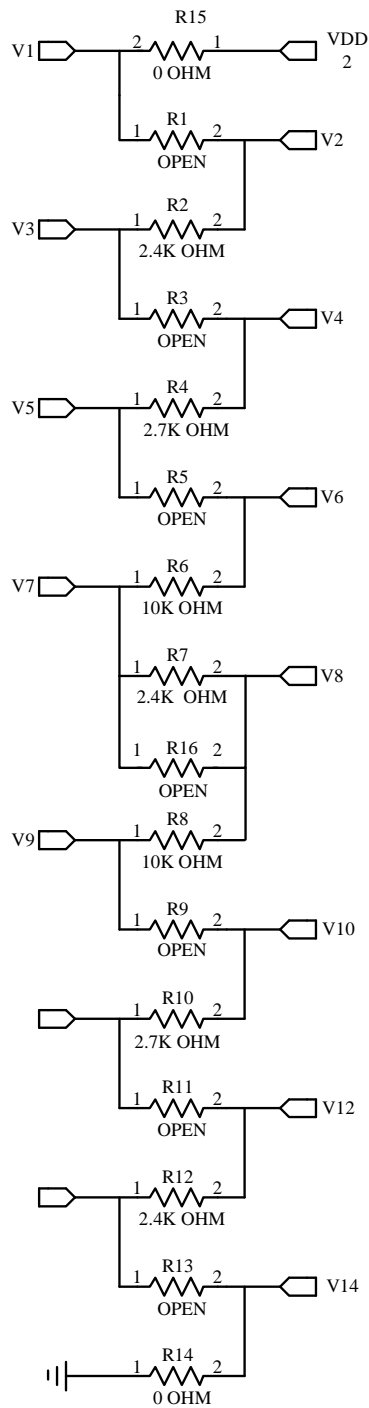
Typical Application Circuit (When  $V_{DD2} = 7.7V$ )

## 5-2) Backlight driving

Connector type: JST BHSR-02VS-1, PIN No 2 pin

Pin No	Symbol	Description	Remark
1	+	Input terminal (Positive electrode side)	Wire color : Red
2	-	Input terminal (Ground side)	Wire Color : Black

6. Absolute Maximum Ratings:

$V_{SS1}=V_{SS2}=GND=0V, T_a=25^{\circ}C$

Parameters	Symbol	MIN.	MAX.	Unit	Remark
Supply Voltage	$V_{DD1}$	-0.5	5.0	V	
	$V_{CC}$	-0.3	6.0	V	
	$V_{DD2}$	-0.5	12.0	V	
	$V_{GG}$	-0.3	40.0	V	
	$V_{GG}-V_{EE}$	-0.3	40.0	V	
	$V_{EE}$	-20	0.3	V	

7. Electrical Characteristics

7-1) Recommended Operating Conditions :

$V_{SS1}=V_{SS2}=GND=0V, T_a=25^{\circ}C$

Item	Symbol	Min.	Typ.	Max.	Unit	Remark
Supply Voltage for Source Driver	$V_{DD1}$	2.3	3.3	3.6	V	
	$V_{DD2}$	-	7.7	-	V	
Supply Voltage for Gate Driver	$V_{GG}$	16	17	18	V	
	$V_{EE}$	-6.0	-5.5	-5.0	V	
	$V_{CC}$	2.3	3.3	5.5	V	
$V_{com}$ Voltage	$V_{com}$	-	2.7	-	V	
Digital Input Voltage	$V_{IH}$	$0.7 V_{CC}$	-	$V_{CC}$	V	
	$V_{IL}$	0	-	$0.3 V_{CC}$	V	

7-2) Recommended driving condition for LED backlight

$GND = 0V, T_a = 25^{\circ}C$

Parameter	Symbol	Min	TYP	MAX	Unit	Remark
Supply voltage of LED backlight	$V_{LED}$	-	11.0	11.5	V	$I_L = 20\text{ mA}$
Supply current of LED backlight	$I_{LED}$	-	20	-	mA	Note 7-1
Backlight Power Consumption	$P_{LED}$	-	1.76	1.84	W	Note 7-2

Note 7-1: The LED driving condition is defined for each LED module. (3 LED Serial)

Note 7-2:  $P_{LED} = V_{LED1} * I_{LED1} + V_{LED2} * I_{LED2} \dots + V_{LED7} * I_{LED7} + V_{LED8} * I_{LED8}$

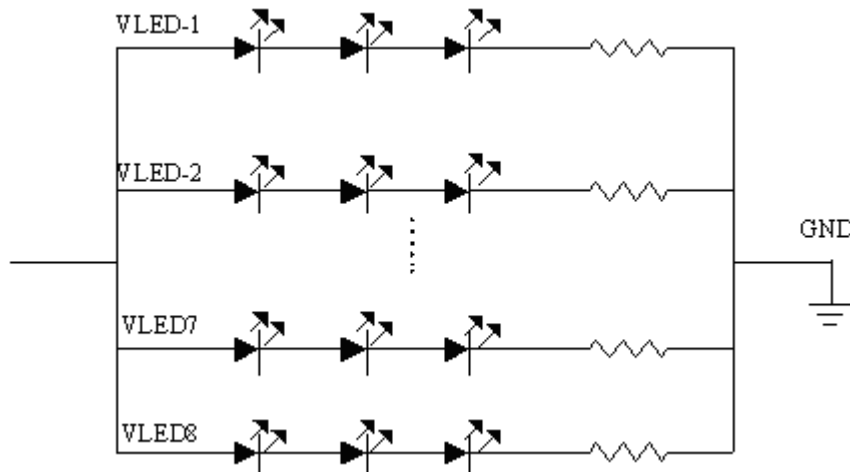

7-3) Power Consumption

Parameter	Symbol	Condition	Typ.	Max.	Unit	Remark
Supply Current for Gate Driver (Hi level)	I <sub>GG</sub>	V <sub>GG</sub> =17V	0.09	0.27	mA	
Supply Current for Gate Driver (Low level)	I <sub>EE</sub>	V <sub>EE</sub> = -5.5V	0.095	0.285	mA	
Supply Current for Source Driver (Digital)	I <sub>DD1</sub>	V <sub>DD1</sub> = 3.3V	5	10	mA	
Supply Current for Source Driver (Analog)	I <sub>DD2</sub>	V <sub>DD2</sub> =7.7V	16.5	33	mA	
Supply Current for Gate Driver (Digital)	I <sub>CC</sub>	V <sub>CC</sub> = 3.3V	0.01	0.03	mA	
LCD Panel Power Consumption	-	-	145.64	293.36	mW	Note 7-3
Backlight Power Consumption	P <sub>LED</sub>	-	1.76	1.84	W	
Total Power Consumption	-	-	1.91	2.13	W	

Note 7-3: The power consumption for backlight is not included.

8. Pixel Arrangement

The LCD module pixel arrangement is the stripe.

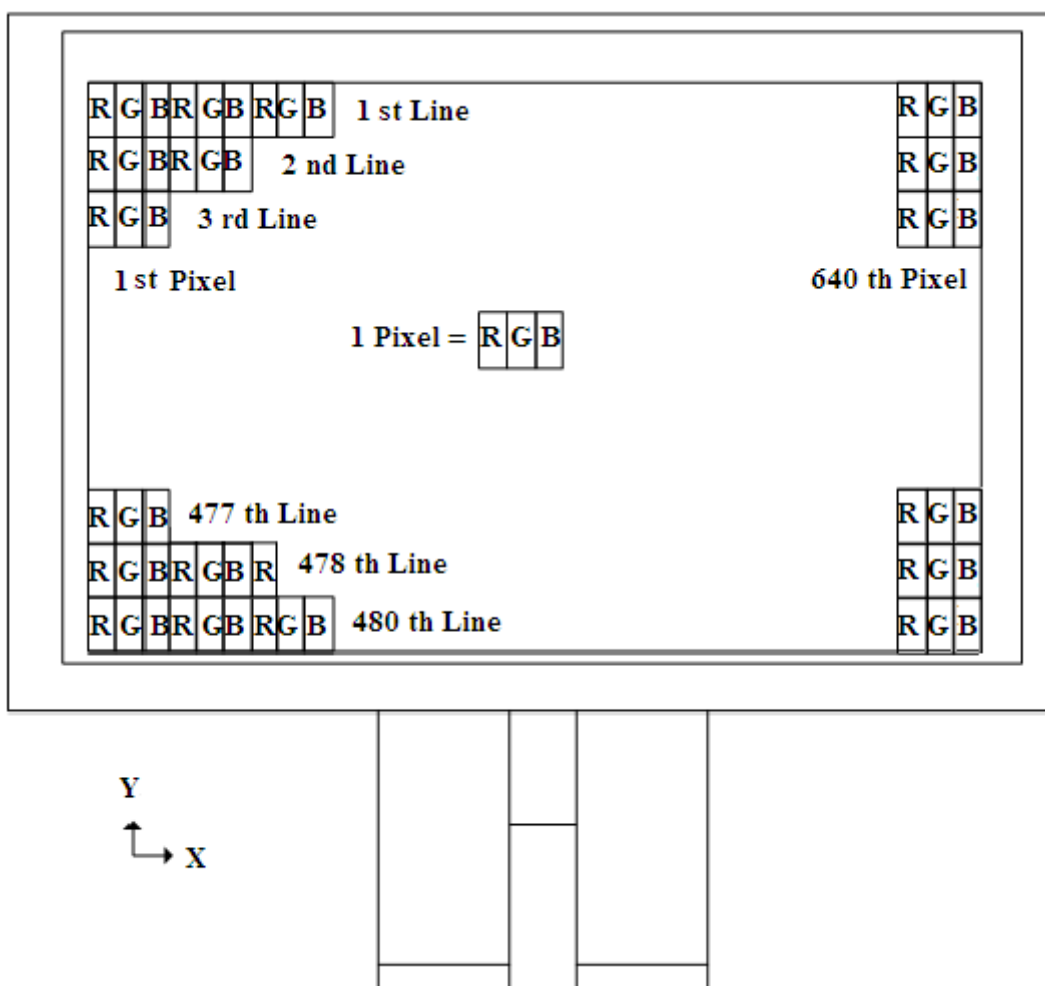

9.Display Color and Gray Scale Reference

Color		Input Color Data																	
		Red						Green						Blue					
		R5	R4	R3	R2	R1	R0	G5	G4	G3	G2	G1	G0	B5	B4	B3	B2	B1	B0
Basic Colors	Black	0	0	0	0	0	0	0	0	0	0	0	0	0	0	0	0	0	0
	Red (63)	1	1	1	1	1	1	0	0	0	0	0	0	0	0	0	0	0	0
	Green (63)	0	0	0	0	0	0	1	1	1	1	1	1	0	0	0	0	0	0
	Blue (63)	0	0	0	0	0	0	0	0	0	0	0	0	1	1	1	1	1	1
	Cyan	0	0	0	0	0	0	1	1	1	1	1	1	1	1	1	1	1	1
	Magenta	1	1	1	1	1	1	0	0	0	0	0	0	1	1	1	1	1	1
	Yellow	1	1	1	1	1	1	1	1	1	1	1	1	0	0	0	0	0	0
	White	1	1	1	1	1	1	1	1	1	1	1	1	1	1	1	1	1	1
Red	Red (00)	0	0	0	0	0	0	0	0	0	0	0	0	0	0	0	0	0	0
	Red (01)	0	0	0	0	0	1	0	0	0	0	0	0	0	0	0	0	0	0
	Red (02)	0	0	0	0	1	0	0	0	0	0	0	0	0	0	0	0	0	0
	Darker																		
	↓	↓	↓	↓	↓	↓	↓	↓	↓	↓	↓	↓	↓	↓	↓	↓	↓	↓	↓
	Brighter																		
	Red (61)	1	1	1	1	0	1	0	0	0	0	0	0	0	0	0	0	0	0
	Red (62)	1	1	1	1	1	0	0	0	0	0	0	0	0	0	0	0	0	0
Red (63)	1	1	1	1	1	1	0	0	0	0	0	0	0	0	0	0	0	0	
Green	Green (00)	0	0	0	0	0	0	0	0	0	0	0	0	0	0	0	0	0	0
	Green (01)	0	0	0	0	0	0	0	0	0	0	0	1	0	0	0	0	0	0
	Green (02)	0	0	0	0	0	0	0	0	0	0	1	0	0	0	0	0	0	0
	Darker																		
	↓	↓	↓	↓	↓	↓	↓	↓	↓	↓	↓	↓	↓	↓	↓	↓	↓	↓	↓
	Brighter																		
	Green (61)	0	0	0	0	0	0	1	1	1	1	0	1	0	0	0	0	0	0
	Green (62)	0	0	0	0	0	0	1	1	1	1	1	0	0	0	0	0	0	0
Green (63)	0	0	0	0	0	0	1	1	1	1	1	1	0	0	0	0	0	0	
Blue	Blue (00)	0	0	0	0	0	0	0	0	0	0	0	0	0	0	0	0	0	0
	Blue (01)	0	0	0	0	0	0	0	0	0	0	0	0	0	0	0	0	0	1
	Blue (02)	0	0	0	0	0	0	0	0	0	0	0	0	0	0	0	0	1	0
	Darker																		
	↓	↓	↓	↓	↓	↓	↓	↓	↓	↓	↓	↓	↓	↓	↓	↓	↓	↓	↓
	Brighter																		
	Blue (61)	0	0	0	0	0	0	0	0	0	0	0	0	1	1	1	1	0	1
	Blue (62)	0	0	0	0	0	0	0	0	0	0	0	0	1	1	1	1	1	0
Blue (63)	0	0	0	0	0	0	0	0	0	0	0	0	1	1	1	1	1	1	

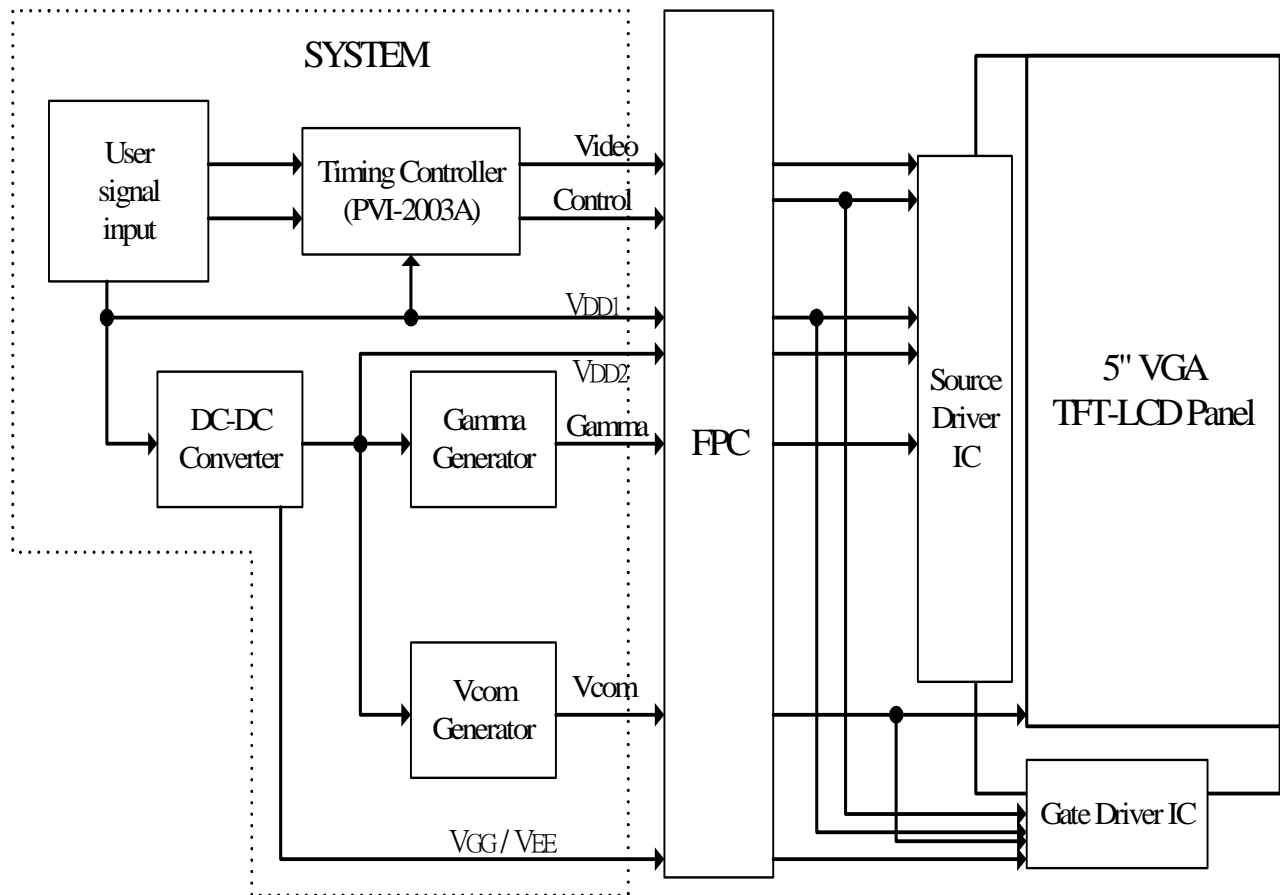
10. Block Diagram  
 10-1) TFT-module Block Diagram

If you use PD050VX6, you can apply PVI-2003A(Timing controller) which will generate timing signals to support PD050VX6.

## 11. Interface Timing

## 11-1) Timing Parameters

AC Electrical Characteristics ( $V_{CC}=V_{DD1}=3.3V$ ,  $V_{DD2}=7.7V$ ,  $GND=V_{SS1}=V_{SS2}=0V$ ,  $T_a=25^{\circ}C$ )

Parameter	Symbol	Min.	Typ.	Max.	Unit
CLK Frequency	Fclk	-	25	40	MHz
CLK Pulse Width	T <sub>cw</sub>	25	40	-	ns
Data Set-up Time	T <sub>su</sub>	4	-	-	ns
Data Hold Time	T <sub>hd</sub>	2	-	-	ns
Propagation Delay of DIO2/1	T <sub>phl</sub>	6	10	15	ns
Time That The Last Data to LD	T <sub>ld</sub>	1	-	-	T <sub>cw</sub>
Pulse width of LD	T <sub>wld</sub>	2	-	-	T <sub>cw</sub>
Time That LD to DIO1/2	T <sub>lds</sub>	5	-	-	T <sub>cw</sub>
POL Set-up Time	T <sub>psu</sub>	6	-	-	ns
POL Hold Time	T <sub>phd</sub>	6	-	-	ns
OE Pulse Width	T <sub>OEV</sub>	1	-	-	μs
CKV Pulse Width	T <sub>CKV</sub>	500	-	-	ns
STV Set-up Time	T <sub>SUV</sub>	400	-	-	ns
STV Hold Time	T <sub>HDV</sub>	400	-	-	ns
Horizontal Display Period	T <sub>HDP</sub>	-	640	-	T <sub>cw</sub>
Horizontal Period Timing Range	T <sub>HP</sub>	-	800	-	T <sub>cw</sub>
Horizontal Lines Per Field	T <sub>V</sub>	520	525	640	T <sub>HP</sub>
Vertical Display Timing Range	T <sub>DV</sub>	-	480	-	T <sub>HP</sub>

11-2) Timing Diagram

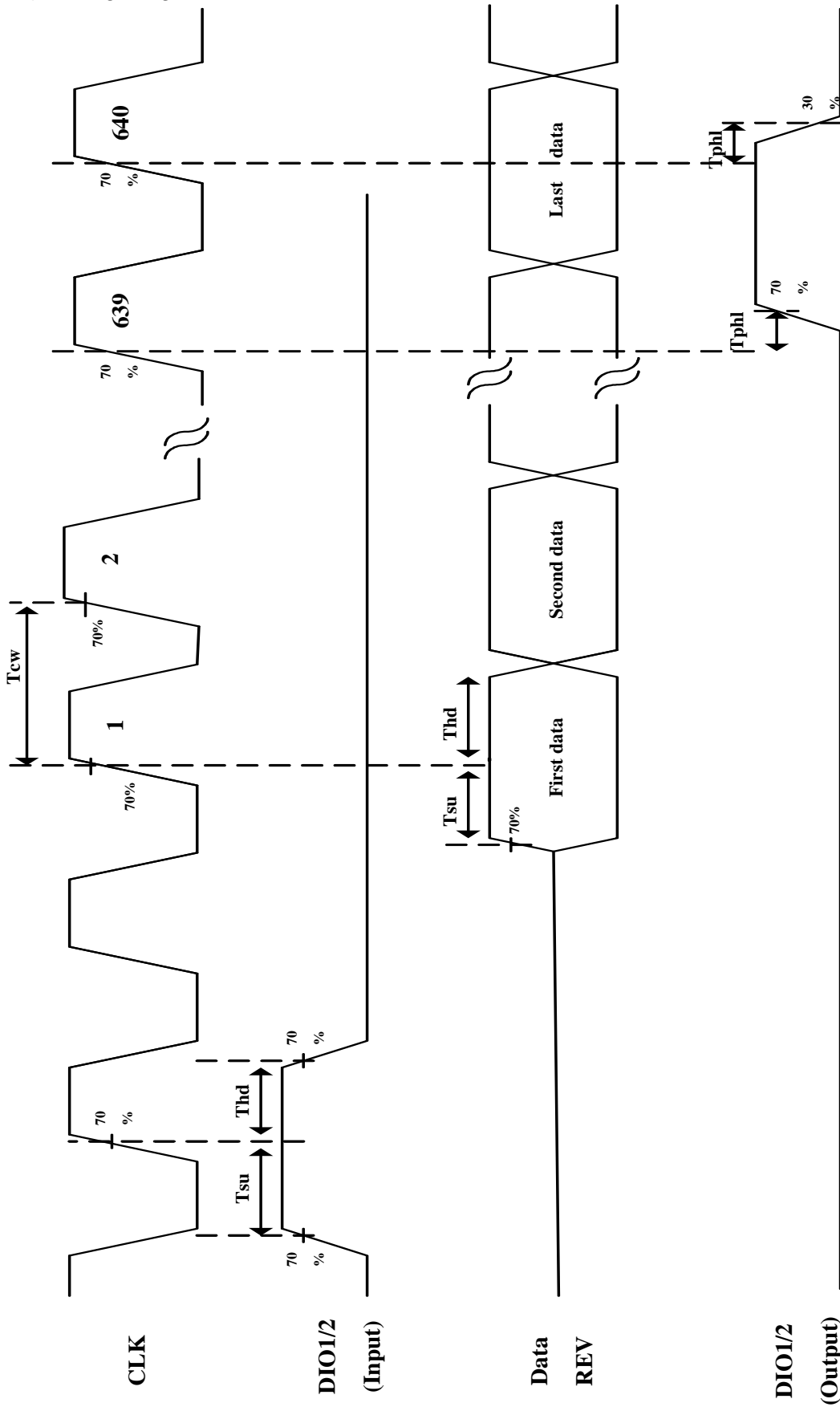

Fig. 11-1 Horizontal timing (1)

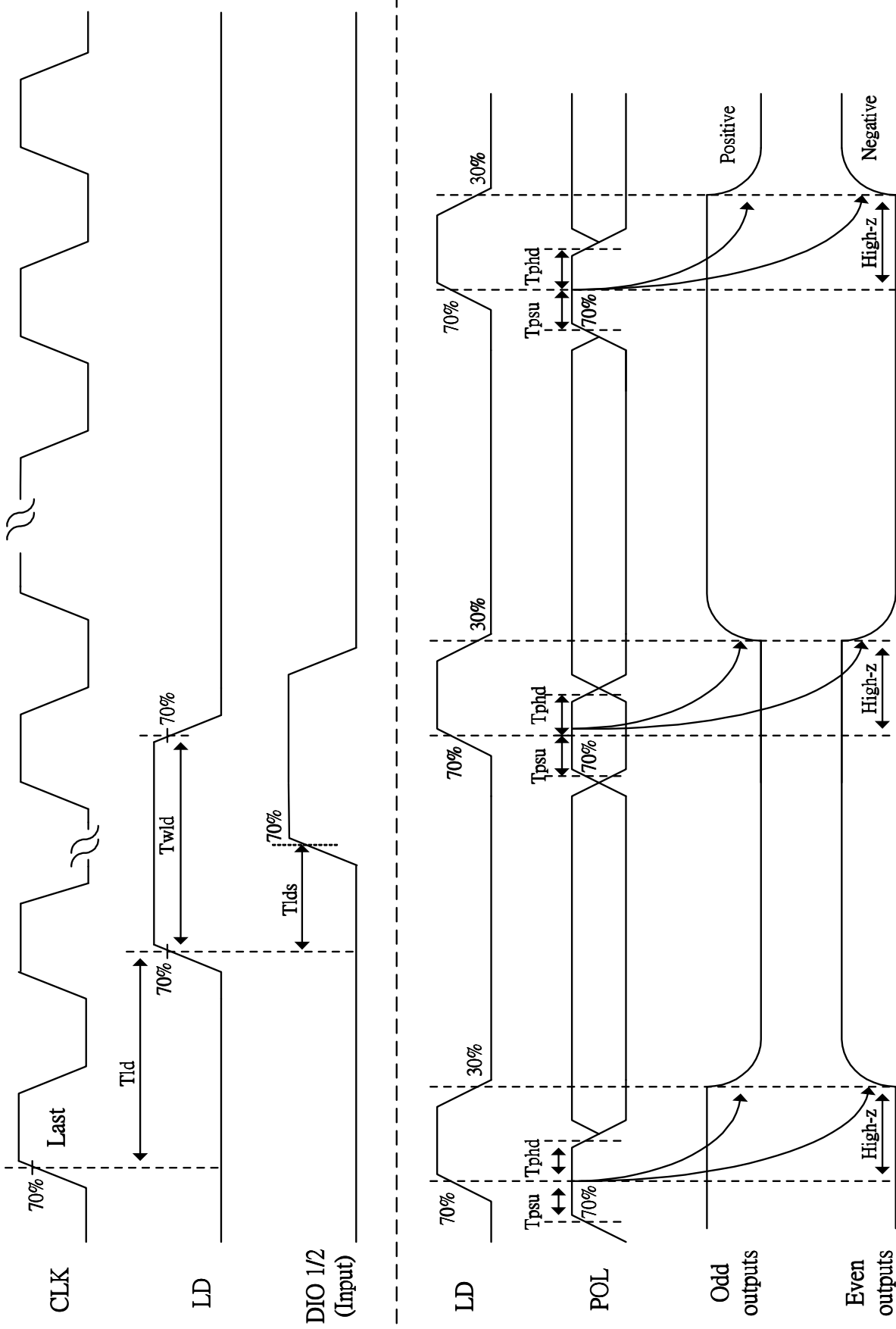

Fig. 11-2 Horizontal timing(2)

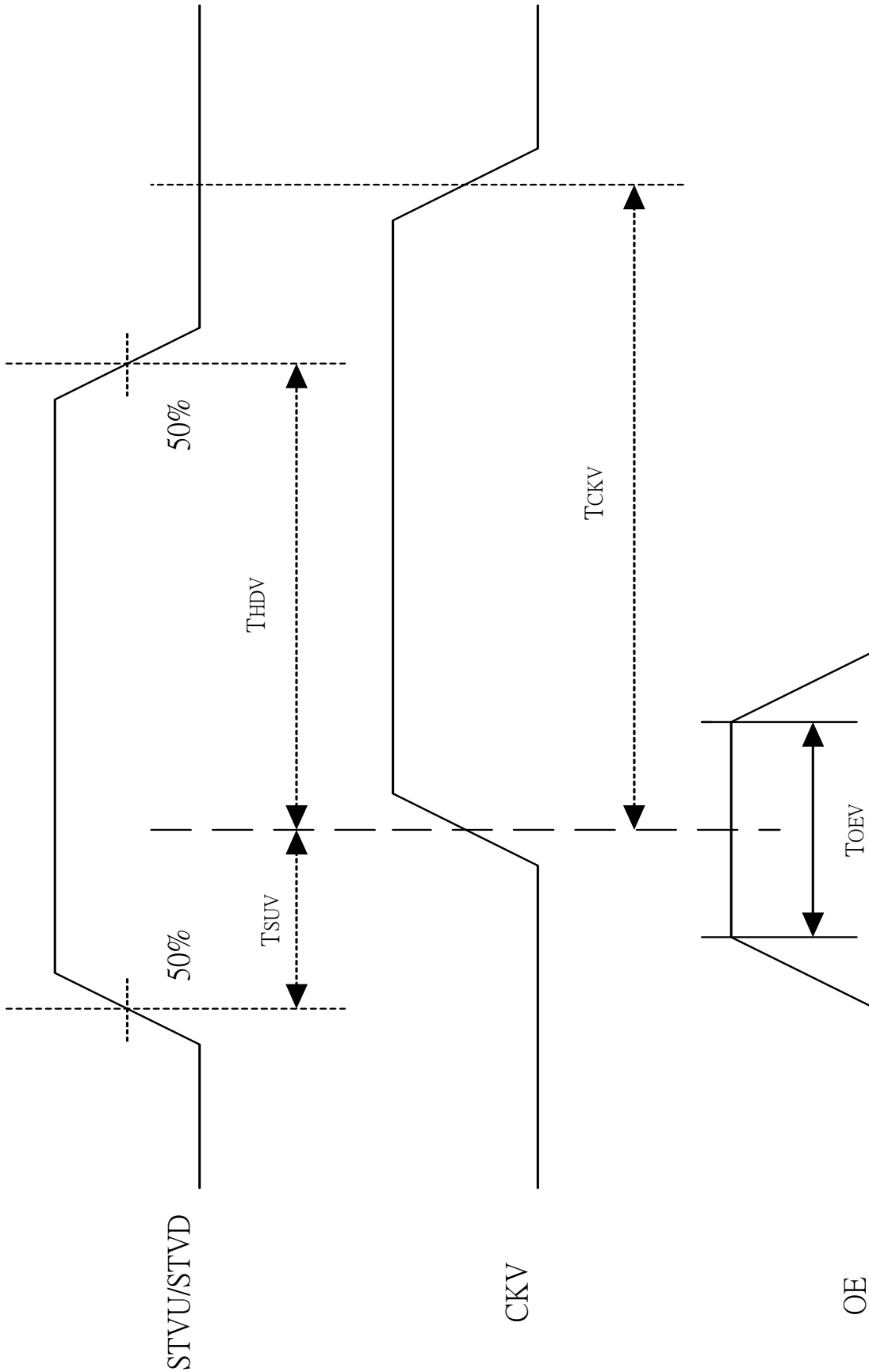

Fig. 11-3 Vertical shift clock timing

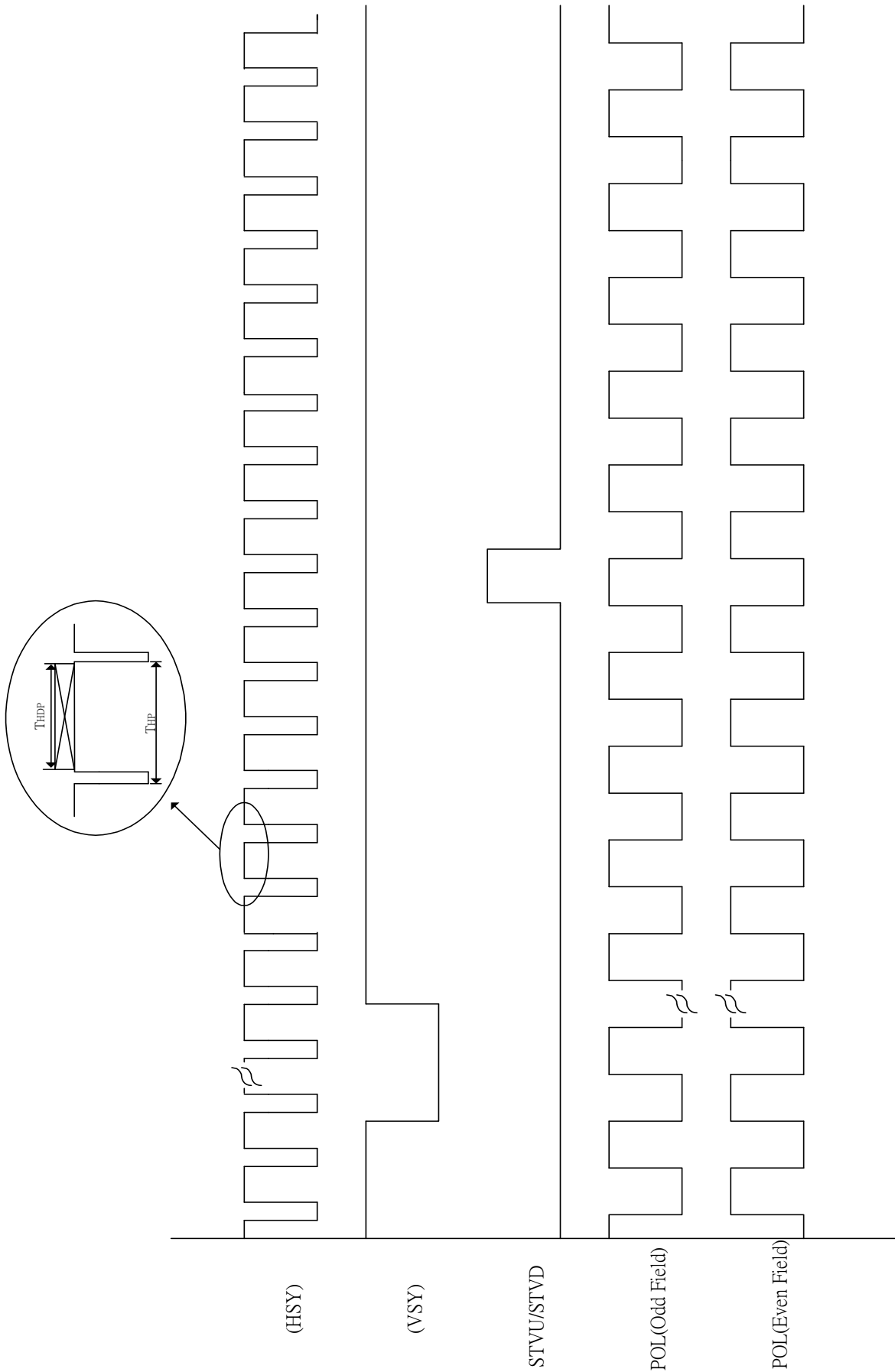
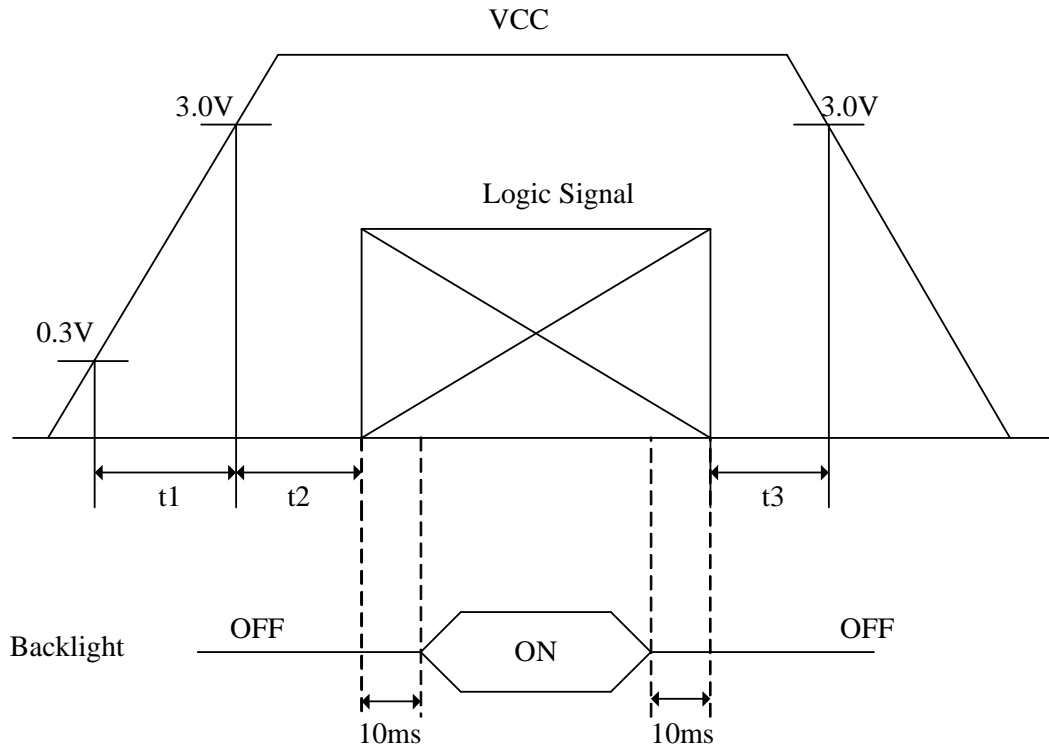

Fig. 11-4 Vertical timing

## 12. Power On Sequence

The information contained herein is the exclusive property of E Ink Holdings Inc., and shall not be distributed, reproduced, or disclosed in whole or in part without prior written permission of E Ink Holdings Inc. Page:19



1.  $0 < t1 \leq 20\text{ms}$
2.  $0 < t2 \leq 50\text{ms}$
3.  $0 < t3 \leq 1\text{s}$

### 13. Optical Characteristics

#### 13-1) Specification:

 $T_a = 25^\circ\text{C}$ 

Parameter	Symbol	Condition	MIN.	TYP.	MAX.	Unit	Remarks		
Viewing Angle	Horizontal	$\theta 21, \theta 22$	CR > 10	65	70	-	deg	Note 13-1	
	Vertical			$\theta 12$	55	60	-		deg
				$\theta 11$	65	70	-		deg
Brightness	L	$\theta = 0^\circ / \varphi = 0$	600	450	-	cd/m <sup>2</sup>	Note 13-2		
Contrast Ratio	CR	At optimized Viewing angle	400	600	-	-	Note 13-3		
Response time	Rise	$\theta = 0^\circ$	-	15	30	ms	Note 13-4		
	Fall			25	50	ms			
Luminance Uniformity	U		70	80	-	%	Note 13-6		
White Chromaticity	x	$\theta = 0^\circ / \varphi = 0$	0.28	0.31	0.34	-	Note 13-2		
	y		0.31	0.34	0.37	-			
Cross Talk		$\theta = 0^\circ$	-	-	3.5	%	Note 13-7		
LED Life Time		25 <sup>o</sup> C	20,000	30,000	-	hrs	Note 13-5		

All the optical measurement shall be executed 30 minutes after backlight being turn-on. The optical characteristics shall be measured in dark room (ambient illumination on panel surface less than 1 Lux). The measuring configuration shows as following figure.

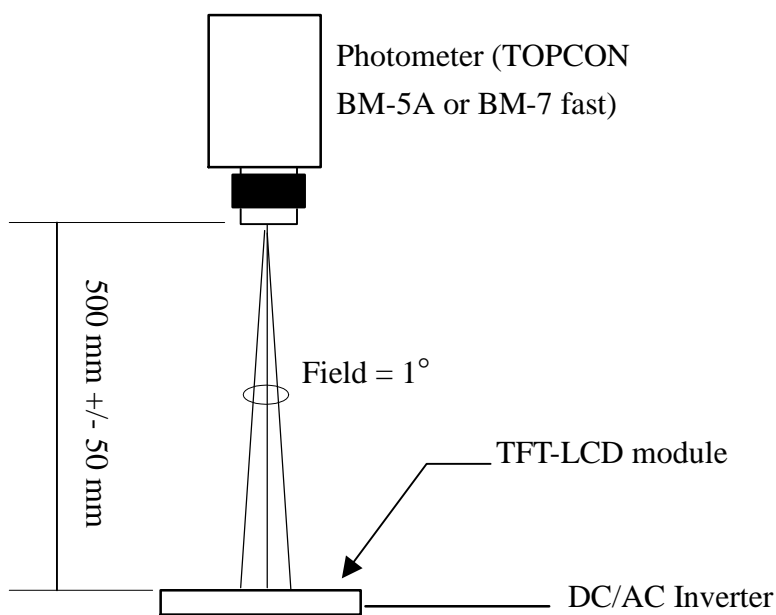

Optical characteristics measuring configuration

Note 13-1: The definitions of viewing angles are as follow

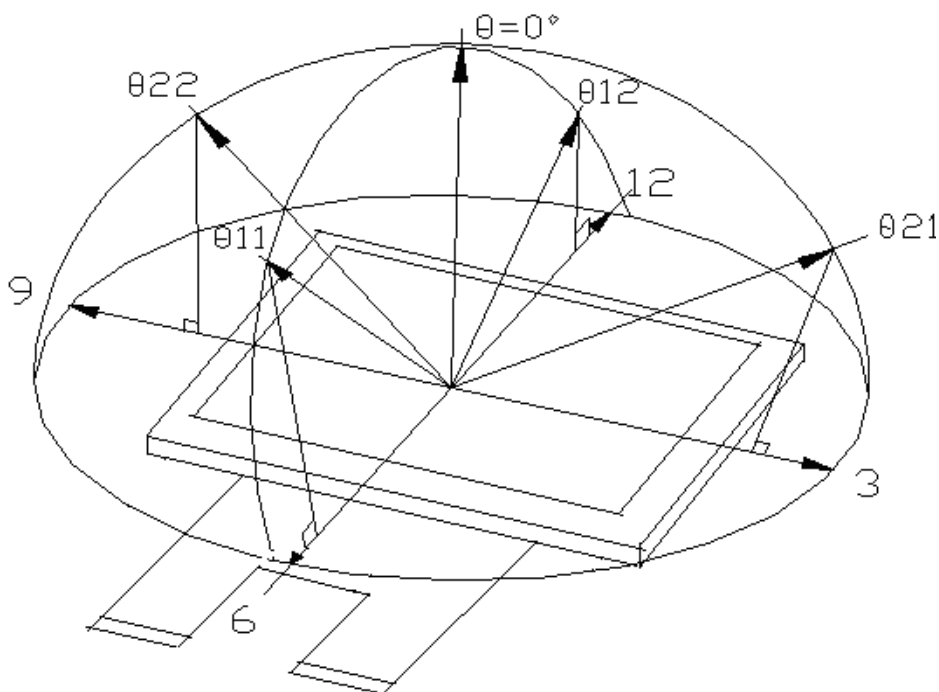

Note 13-2: Topcon BM-5A or BM-7 fast luminance meter 1° field of view is used in the testing (after 1 minute operation).

Note 13-3: The definition of contrast ratio  $CR = \frac{\text{Luminance at gray level 63}}{\text{Luminance at gray level 0}}$

Note 13-4: Definition of Response Time  $T_r$  and  $T_f$ :

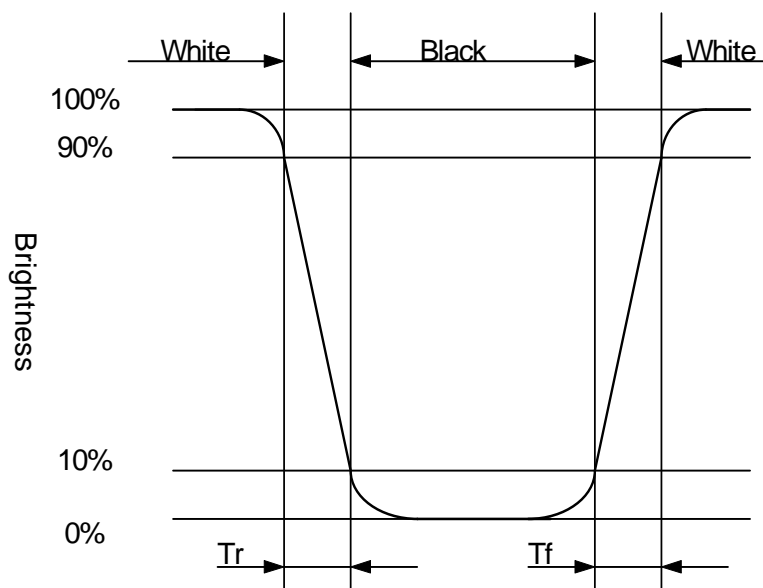

Note 13-5: The “LED Life time “ is defined as the module brightness decrease to 50% original Brightness that the ambient temperature is 25°C and  $I_{LED} = 20mA$ .

Note 13-6: The uniformity of LCD is defined as

$$U = \frac{\text{The Minimum Brightness of the 9 testing Points}}{\text{The Maximum Brightness of the 9 testing Points}}$$

Luminance meter : BM-5A or BM-7 fast(TOPCON)  
 Measurement distance : 500 mm +/- 50 mm  
 Ambient illumination : < 1 Lux  
 Measuring direction : Perpendicular to the surface of module  
 The test pattern is white (Gray Level 63).

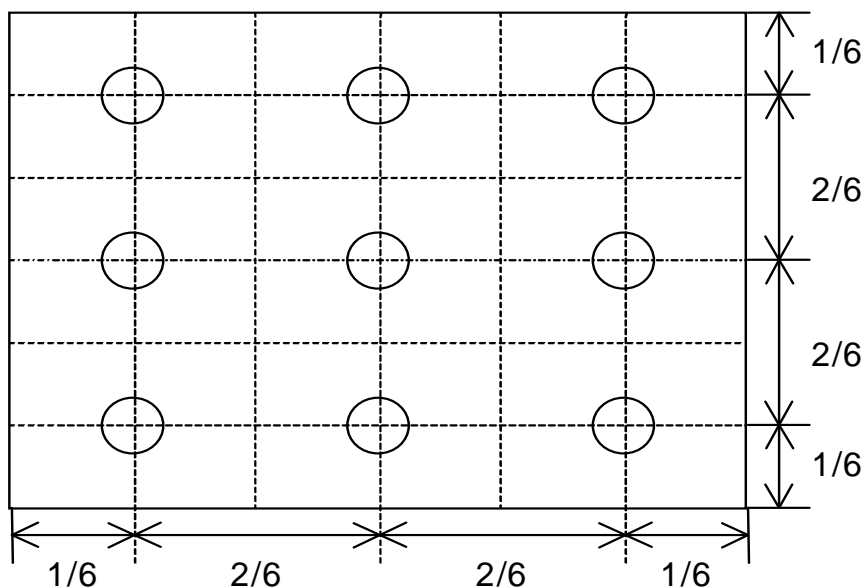

Note 13-7: Cross Talk (CTK) =  $\frac{|YA-YB|}{YA} \times 100\%$

YA: Brightness of Pattern A

YB: Brightness of Pattern B

Luminance meter : BM 5A or BM-7 fast (TOPCON)

Measurement distance : 500 mm +/- 50 mm

Ambient illumination : < 1 Lux

Measuring direction : Perpendicular to the surface of module

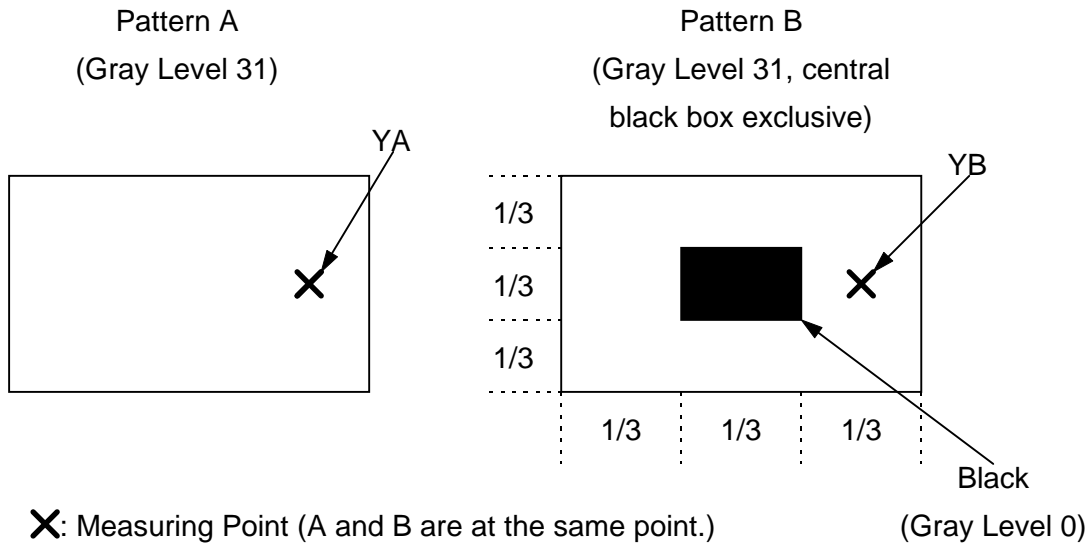

## 14. Handling Cautions

### 14-1) Mounting of module

- a) Please power off the module when you connect the input/output connector.
- b) Polarizer which is made of soft material and susceptible to flaw must be handled carefully.
- c) Protective film (Laminator) is applied on surface to protect it against scratches and dirt.
- d) Please following the tear off direction as figure14-1 to remove the protective film as slowly as possible, so that electrostatic charge can be minimized.

### 14-2) Precautions in mounting

- a) Wipe off water drops or finger grease immediately. Long contact with water may cause discoloration or spots.
- b) TFT-LCD module uses glass which breaks or cracks easily if dropped or bumped on hard surface. Please handle with care.
- c) Since CMOS LSI is used in the module. So take care of static electricity and earth yourself when handling.

### 14-3) Others

- a) Do not expose the module to direct sunlight or intensive ultraviolet rays for many hours.
- b) Store the module at a room temperature place.
- c) The voltage of beginning electric discharge may over the normal voltage because of leakage current from approach conductor by to draw lump read lead line around.
- d) If LCD panel breaks, it is possibly that the liquid crystal escapes from the panel.  
Avoid putting it into eyes or mouth. When liquid crystal sticks on hands, clothes or feet. Wash it out immediately with soap.
- e) Observe all other precautionary requirements in handling general electronic components.
- f) Please adjust the voltage of common electrode as material of attachment by 1 module.

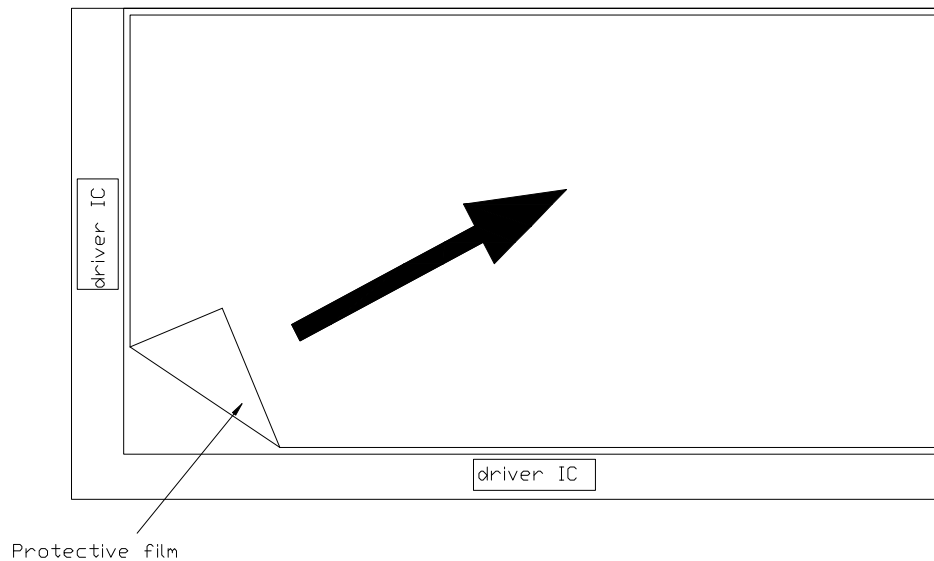

Figure 14-1 the way to peel off protective film

## 15. Reliability Test

No	Test Item	Test Condition
1	High Temperature Storage Test	Ta = +90°C, 240 hrs
2	Low Temperature Storage Test	Ta = -40°C, 240 hrs
3	High Temperature Operation Test	Ta = +80°C, 240 hrs
4	Low Temperature Operation Test	Ta = -30°C, 240 hrs
5	High Temperature & High Humidity Operation Test	Ta = +60°C, 90%RH, 240 hrs
6	Thermal Cycling Test (non-operating)	-30°C → +80°C, 200 Cycles 30 min 30 min
7	Vibration Test (non-operating)	Frequency : 10 ~ 55 Hz Amplitude : 1 mm Sweep time: 11 mins Test Period: 6 Cycles for each direction of X, Y, Z
8	Shock Test (non-operating)	100G, 6ms Direction: ±X, ±Y, ±Z Cycle: 3 times
9	Electrostatic Discharge Test (non-operating)	200pF, 0Ω ±200V 1 time / each terminal

Ta: ambient temperature

[Criteria]

In the standard conditions, there is not display function NG issue occurred. (including : line defect ,no image).All the cosmetic specification is judged before the reliability stress.

16. Packing Diagram

REV	DESCRIPTION	DESIGN	DATE
01	INITIAL RELRASE	Patrick Lin	2006.09.12
△02	CHG 50-0500091 to 50-0510092	Patrick Lin	2009.08.14

**NOTE:**  
 1.Q'TY: 40 pcs panel/carton.  
 2.Dimension: 530\*295\*230mm  
 3.Weight: 8 Kg

ITEM	PART NO.	DESCRIPTION	QTY	REMARK
4	50-0100111	CARTON	1	
3	50-0510092	PINK Bag 195*105mm	40	抗靜電
2		5" Module	40	
1	50-0300381	瓦楞隔板緩衝材	1	上蓋+底座

MTL.SPEC.		UNSPECIFIED TOL'S		REMARK	
		ANGLE			
		ROUGHNESS			
APPROVE	Franks	'06.09.12	SCALE	UNIT	SHEET
CHECK	Franks	'06.09.12			1 OF 1
DRAWN	Patrickl	'06.09.12	MTL.NO.		DWG.TITLE
					PD050VX6 Packing Draw
				DWG FILE:	REV. 01
					A4 SIZE