

TFT-Display Datenblatt

Modell SCF0507894GGC00

Kurzdaten

Hersteller	Data Image
Diagonale	5,7" / 14,5cm
Format	04:03
Auflösung	640x480
Backlight	LED / 340cd/m ²
Interface	RGB
Touchscreen	ja
Temperatur	-20...+70°C (Betrieb)

HY-LINE Computer Components Vertriebs GmbH
Inselkammerstr. 10, 82008 Unterhaching bei München
Tel.: +49 89 614 503 40 || Fax: +49 89 614 503 50
computer@hy-line.de || www.hy-line.de/computer



DATA IMAGE CORPORATION



TFT Module Specification

Preliminary

ITEM NO.: SCF0507894GGC00

Table of Contents

1. COVER & CONTENTS	1
2. RECORD OF REVISION	2
3. APPLICATION.....	3
4. GENERAL SPECIFICATIONS	3
5. ABSOLUTE MAXIMUM RATINGS	3
6. ELECTRICAL CHARACTERISTICS	3
7. BLOCK DIAGRAM	4
8. PIN CONNECTIONS	5
9. INTERFACE SPECIFICATIONS	7
10. OPTICAL CHARACTERISTIC	11
11. QUALITY ASSURANCE	14
12. APPEARANCE SPECIFICATION	17
13. QUALITY ASSURANCE.....	19
14. CTP LCM PRODUCT LABEL DEFINE	20
15. PRECAUTION FOR USING LCM.....	22
15. OUTLINE DRAWING	23
16. PACKAGE INFORMATION	24

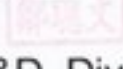
Approved by	Checked by  QC. Div	Checked by  Pro. Div	Checked by   R&D. Div.	Drawn by
	Final Revision: 1	Sheet Code:	Issued Date: 3/DEC/10	Total Page: 24

3. APPLICATION

Digital equipments which need color display, such as P.O.S, medical equipments and industrial equipments.

4. GENERAL SPECIFICATIONS

Composition: 5.7inch VGA resolution display with a projected Capacitive Touch Panel (CTP).
Interface : 18bit parallel RGB for panel and I²C for the CTP.

Parameter	Specifications	Unit
Display resolution	(640X R.G.B) (W) x480(H)	dot
Active area	115.2(W) x 86.4(H)	mm
Screen size	5.7(Diagonal)	inch
Dot pitch	0.06(W) x 0.18(H)	mm
Color configuration	R.G.B. Stripe	
Overall dimension	142.75 (W) x 113.95(H) x 9.3Max.(T)	mm
Weight	TBD	g
Surface treatment	TBD	
View Angle direction	12 o'clock	
Our components and processes are compliant to RoHS standard		

5. ABSOLUTE MAXIMUM RATINGS

Parameter	Symbol	MIN.	MAX.	Unit	Remark
Power supply voltage	V _{CC}	-0.3	5.0	V	
Logic input voltage	V _I	-0.3	V _{CC} +0.3	V	
Operating temperature	T _{op}	-20	+70	°C	Ambient temperature
Storage temperature	T _{st}	-25	+80	°C	Ambient temperature

6. ELECTRICAL CHARACTERISTICS

VSS=0V,DCLK=25MHz,Ta=25°C

Parameter	Symbol	MIN.	Typ.	MAX.	Unit	Remark
Power Supply voltage for LCD	V _{CC}	+3.0	+3.3	+3.6	V	
Power Supply Current for LCD	I _{CC}		111	140	mA	V _{CC} =3.3V
Power Supply voltage for LED	V _{LED}	4.5	5	5.5	V	
Power Supply Current for LED	I _{LED}		333	400	mA	V _{LED} =5.0V
Ripple voltage	V _{RF}	-	-	100	mV _{P-P}	
"H" level logical input voltage	V _{IH}	0.7V _{CC}	--	V _{CC}	V	
"L" level logical input voltage	V _{IL}	0	--	0.3V _{CC}	V	
ADJ frequency		19K	20K	21K	Hz	
ADJ input voltage	V _{IH}	3.0	-	3.3	V	
	V _{IL}	0	-	0.3	V	
LED Dice life time		--	50000	--	Hr	Note 1

Note 1: The "LED dice life time" is defined as the brightness decrease to 50% original brightness that the ambient temperature is 22°C and LED dice current=20mA.

7. BLOCK DIAGRAM

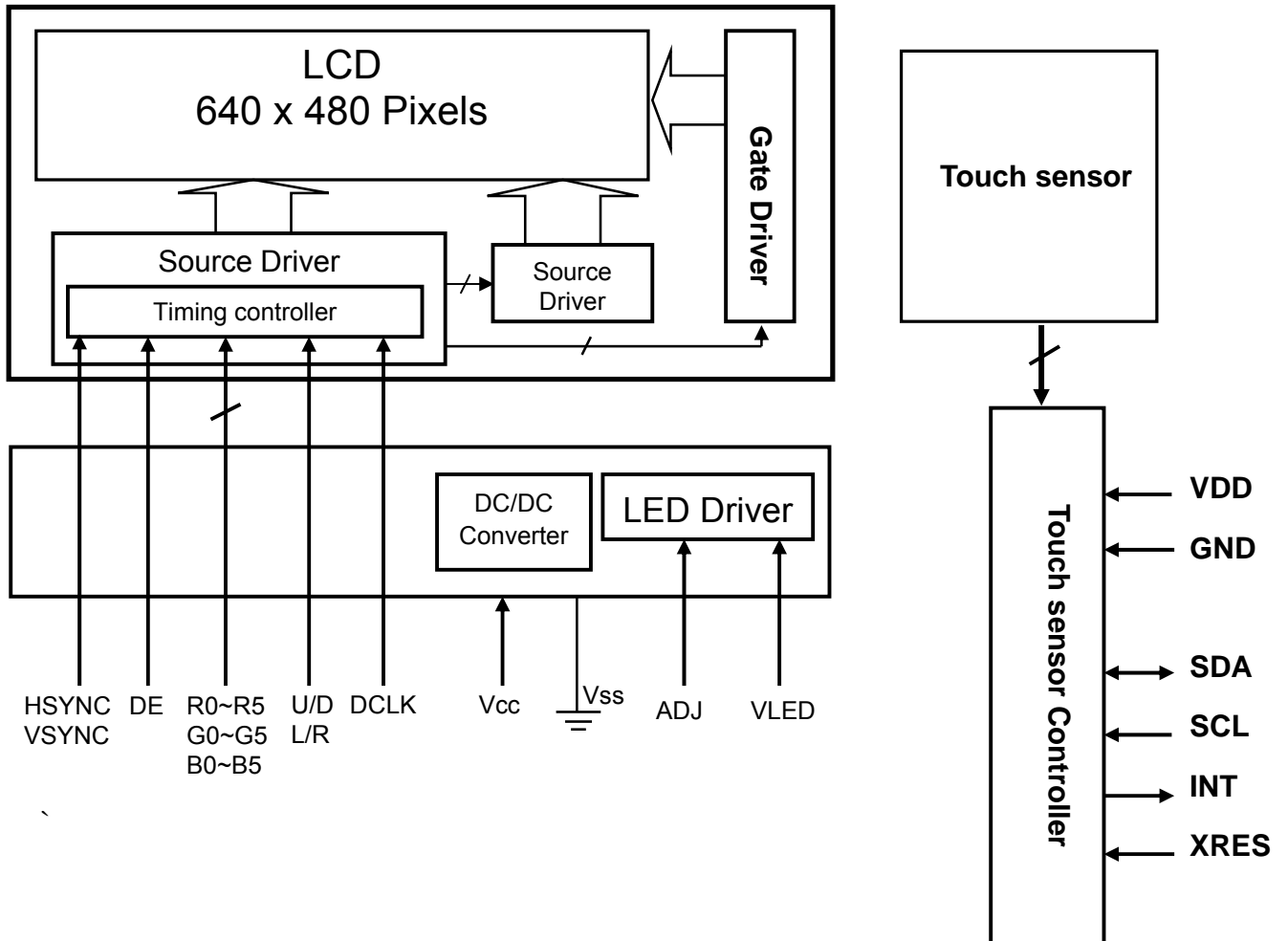

8. PIN CONNECTIONS

Pin NO.	SYMBOL	DESCRIPTION
1	U/D	Up or Down Display Control
2	NC	No Connection
3	Hsync	Horizontal SYNC.
4	VLED	Power Supply for LED Driver circuit
5	VLED	Power Supply for LED Driver circuit
6	VLED	Power Supply for LED Driver circuit
7	Vcc	Power Supply for LCD
8	Vsync	Vertical SYNC.
9	DE	Data Enable
10	VSS	Power Ground
11	VSS	Power Ground
12	ADJ	Brightness control for LED B/L
13	B5	Blue Data 5 (MSB)
14	B4	Blue Data 4
15	B3	Blue Data 3
16	VSS	Power Ground
17	B2	Blue Data 2
18	B1	Blue Data 1
19	B0	Blue Data 0 (LSB)
20	VSS	Power Ground
21	G5	Green Data 5 (MSB)
22	G4	Green Data 4
23	G3	Green Data 3
24	VSS	Power Ground
25	G2	Green Data 2
26	G1	Green Data 1
27	G0	Green Data 0 (LSB)
28	VSS	Power Ground
29	R5	Red Data 5 (MSB)
30	R4	Red Data 4
31	R3	Red Data 3
32	VSS	Power Ground
33	R2	Red Data 2
34	R1	Red Data 1
35	R0	Red Data 0
36	VSS	Power Ground
37	VSS	Power Ground
38	DCLK	Clock Signals ; Latch Data at the Falling Edge
39	VSS	Power Ground
40	L/R	Left or Right Display Control

Remarks :

- 1) ADJ is brightness control Pin. The larger of the pulse duty is the higher of the brightness.
- 2) ADJ signal is 0~3.3V.Operation frequency is 20KHz.
- 3) VSS PIN must be grounding, can not be floating.

4) U/D and L/R control Function

L/R	U/D	Function
1	0	Normally display
0	0	Left and Right opposite
1	1	Up and Down opposite
0	1	Left and Right opposite , Up and Down opposite

5) If DE signal is fixed low, SYNC mode is used. Otherwise, DE mode is used.

Power Signal Sequence

Remarks:

*1) Power Signal sequence:

$t1 \leq 10\text{ms}$: $1 \text{ sec} \leq t5$

$50\text{ms} \leq t2$: $200\text{ms} \leq t6$

$0 < t3 \leq 50\text{ms}$: $200\text{ms} \leq t7$

$0 < t4 \leq 10\text{ms}$

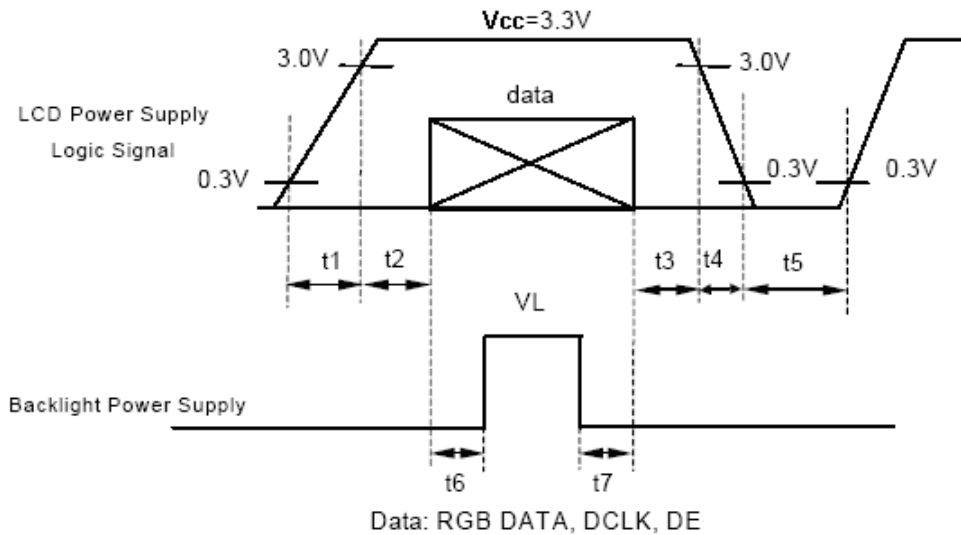

*2) VCC-dip condition:

(1) $2.7 \text{ V} \leq VCC < 3.0\text{V}$, $t_d \leq 10 \text{ ms}$

(2) $VCC > 3.0\text{V}$, VCC-dip condition should be the same with VCC-turn-on condition ◦

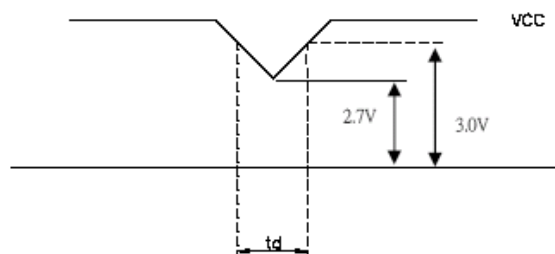

9. INTERFACE SPECIFICATIONS

9.1 DE mode Input signal characteristics

Signal	Parameter	Symbol	MIN.	TYP.	MAX.	Unit	Remarks
DCLK	Period	t_{CLK}	33	40	43	ns	
	Frequency	f_{CLK}	23	25	30	MHz	
	Low Level Width	t_{WCL}	6	-	-	ns	
	High Level Width	t_{WCH}	6	-	-	ns	
	Rise, Fall Time	t_{CLKr}, t_{CLKf}	-	-	3	ns	
	Duty	-	0.45	0.50	0.55	-	
DE (Data Enable)	Setup Time	t_{DES}	5	-	-	ns	
	Hold Time	t_{DEH}	10	-	-	ns	
	Rise, Fall Time	t_{DEr}, t_{DEf}	-	-	16	ns	
	Horizontal Period	t_{HP}	750	800	900	t_{CLK}	
	Horizontal Valid	t_{HV}	640	640	640	t_{CLK}	
	Horizontal Blank	t_{HBK}	110	160	260	t_{CLK}	
	Vertical Period	t_{VP}	515	525	560	t_{HP}	
	Vertical Valid	t_{WV}	480	480	480	t_{HP}	
	Vertical Blank	t_{VBK}	35	45	80	t_{HP}	
	Vertical Frequency	f_V	55	60	65	Hz	
Data R,G,B	Setup Time	t_{DS}	5	-	-	ns	
	Hold Time	t_{DH}	10	-	-	ns	
	Rise, Fall Time	t_{Dr}, t_{Df}	-	-	3	ns	

9.1.1 DE mode timing waveform

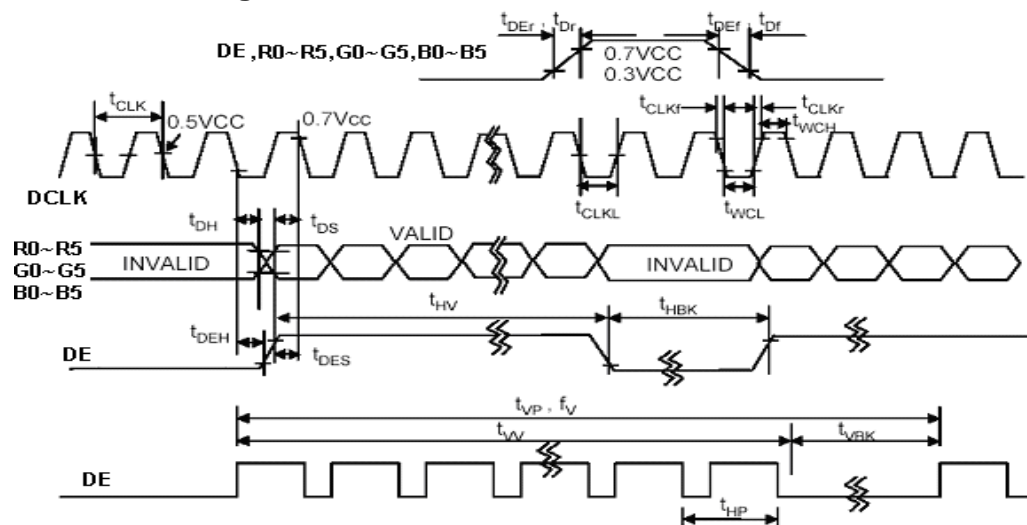

9.2 SYNC mode Input signal characteristics

Parameter	Symbol	MIN.	TYP.	MAX.	Unit	Remarks
Clock Period	t_{CLK}	33	40	43	ns	
Clock Frequency	f_{CLK}	23	25	30	MHz	
Clock Low Level Width	t_{WCL}	6	-	-	ns	
Clock High Level Width	t_{WCH}	6	-	-	ns	
Clock Rise, Fall Time	t_{CLKr}, t_{CLKf}	-	-	3	ns	
HSYNC Period	t_{HP}	750	800	900	t_{CLK}	
HSYNC Pulse Width	t_{HW}	5	30	-	t_{CLK}	
HSYNC Front Porch	t_{HFP}	1	16	116	t_{CLK}	
HSYNC Back Porch	t_{HBP}	1	114	139	t_{CLK}	
HSYNC Width + Back Porch	$t_{HW} + t_{HBP}$	144	144	144	t_{CLK}	
Horizontal Blank	t_{HBK}	1	160	260	t_{CLK}	
Horizontal Valid	t_{HV}	640	640	640	t_{CLK}	
VSYNC Period	t_{VP}	515	525	560	t_{HP}	
VSYNC Pulse Width	t_{VW}	1	3	5	t_{HP}	
VSYNC Front Porch	t_{VFP}	1	10	45	t_{HP}	
VSYNC Back Porch	t_{VBP}	30	32	34	t_{HP}	
VSYNC Width + Back Porch	$t_{VW} + t_{VBP}$	35	35	35	t_{CLK}	
Vertical Blank	t_{VBK}	35	45	80	t_{HP}	
Valid data Width	t_W	480	480	480	t_{HP}	
Data Setup Time	t_{DS}	5	-	-	ns	
Data Hold Time	t_{DH}	10	-	-	ns	

Note: (1) $t_{HBK} = t_{HFP} + t_{HW} + t_{HBP}$

9.2.1 SYNC mode timing waveform

9.2.1.1 Input vertical timing

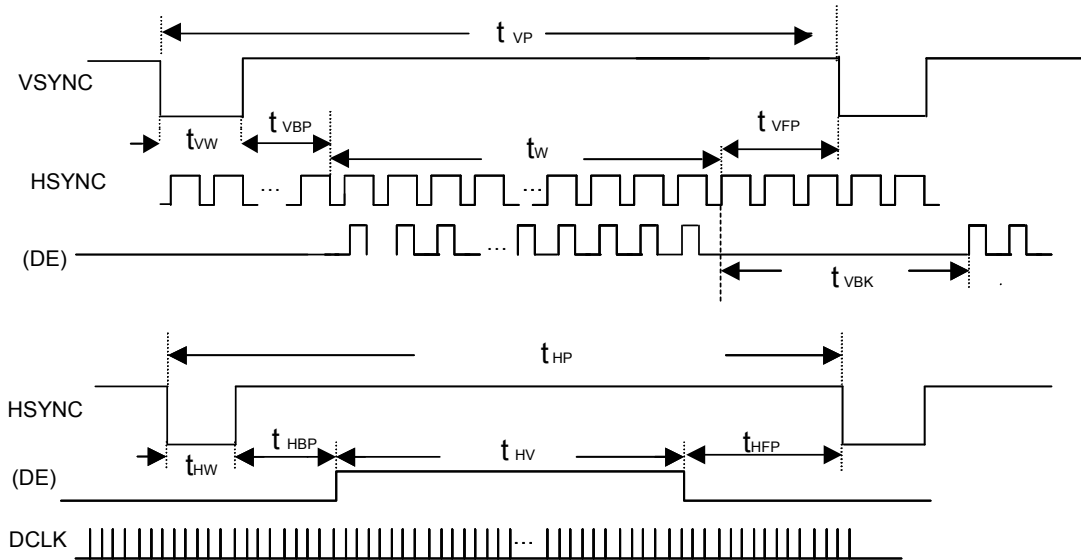

Remark : If SYNC mode is used, please fix DE signal to low, DE timing waveform is for reference only.

9.2.1.2 Input horizontal timing

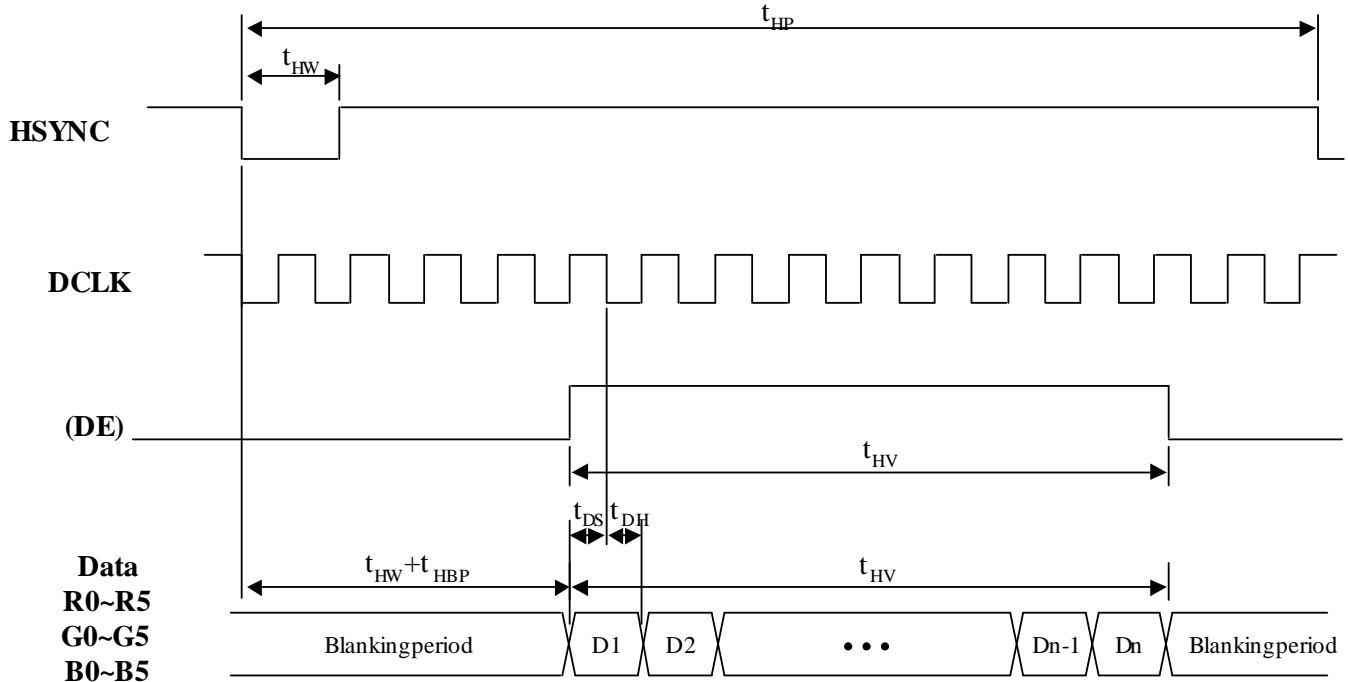

Remark : If SYNC mode is used, please fix DE signal to low, DE timing waveform is for reference only.

9.3 Color Data Assignment

COLOR	INPUT	R DATA						G DATA						B DATA					
	DATA	R5	R4	R3	R2	R1	R0	G5	G4	G3	G2	G1	G0	B5	B4	B3	B2	B1	B0
		MSB					LSB	MSB					LSB	MSB					LSB
BASIC COLOR	BLACK	0	0	0	0	0	0	0	0	0	0	0	0	0	0	0	0	0	0
	RED(63)	1	1	1	1	1	1	0	0	0	0	0	0	0	0	0	0	0	0
	GREEN(63)	0	0	0	0	0	0	1	1	1	1	1	1	0	0	0	0	0	0
	BLUE(63)	0	0	0	0	0	0	0	0	0	0	0	0	1	1	1	1	1	1
	CYAN	0	0	0	0	0	0	1	1	1	1	1	1	1	1	1	1	1	1
	MAGENTA	1	1	1	1	1	1	0	0	0	0	0	0	1	1	1	1	1	1
	YELLOW	1	1	1	1	1	1	1	1	1	1	1	1	0	0	0	0	0	0
	WHITE	1	1	1	1	1	1	1	1	1	1	1	1	1	1	1	1	1	1
RED	RED(0)	0	0	0	0	0	0	0	0	0	0	0	0	0	0	0	0	0	0
	RED(1)	0	0	0	0	0	1	0	0	0	0	0	0	0	0	0	0	0	0
	RED(2)	0	0	0	0	1	0	0	0	0	0	0	0	0	0	0	0	0	0
	:	:	:	:	:	:	:	:	:	:	:	:	:	:	:	:	:	:	:
	:	:	:	:	:	:	:	:	:	:	:	:	:	:	:	:	:	:	:
	RED(62)	1	1	1	1	1	0	0	0	0	0	0	0	0	0	0	0	0	0
	RED(63)	1	1	1	1	1	1	0	0	0	0	0	0	0	0	0	0	0	0
GREEN	GREEN(0)	0	0	0	0	0	0	0	0	0	0	0	0	0	0	0	0	0	0
	GREEN(1)	0	0	0	0	0	0	0	0	0	0	0	1	0	0	0	0	0	0
	GREEN(2)	0	0	0	0	0	0	0	0	0	0	1	0	0	0	0	0	0	0
	:	:	:	:	:	:	:	:	:	:	:	:	:	:	:	:	:	:	:
	:	:	:	:	:	:	:	:	:	:	:	:	:	:	:	:	:	:	:
	GREEN(62)	0	0	0	0	0	0	1	1	1	1	1	0	0	0	0	0	0	0
	GREEN(63)	0	0	0	0	0	0	1	1	1	1	1	1	0	0	0	0	0	0
BLUE	BLUE(0)	0	0	0	0	0	0	0	0	0	0	0	0	0	0	0	0	0	0
	BLUE(1)	0	0	0	0	0	0	0	0	0	0	0	0	0	0	0	0	0	1
	BLUE(2)	0	0	0	0	0	0	0	0	0	0	0	0	0	0	0	0	1	0
	:	:	:	:	:	:	:	:	:	:	:	:	:	:	:	:	:	:	:
	:	:	:	:	:	:	:	:	:	:	:	:	:	:	:	:	:	:	:
	BLUE(62)	0	0	0	0	0	0	0	0	0	0	0	0	1	1	1	1	1	0
	BLUE(63)	0	0	0	0	0	0	0	0	0	0	0	0	1	1	1	1	1	1

Remarks: (1) Definition of Gray Scale color (n):n is series of Gray Scale ;The more n value is, the bright Gray Scale.
 (2)Data: 1-High,0-Low

Correspondence between Data and Display Position

	S0001	S0002	S0003	S0004	S0005	S0006	S0007	S0008	-----	S1919	S1920
C001	R001	G001	B001	R002	G002	B002	R003	G003		G640	B640
C480	R001	G001	B001	R002	G002	B002	R003	G003		G640	B640

10. Optical Characteristic Specification:

Parameter	Symbol	Condition	MIN.	TYP.	MAX.	Unit	Remarks	
Viewing Angle	Horizontal	θ_{x+}	60	70	--	deg	Note 1,4	
		θ_{x-}	60	70	--			
	Vertical	θ_{y+}	50	60	--			
		θ_{y-}	30	40	--			
Contrast Ratio	CR	at optimized viewing angle	200	300			Note 1,3	
Response time	Rise	Tr	-	15		ms	Note 1,6	
	Fall	Tf	-	35		ms		
Uniformity		B-uni	$\theta x = \theta y = 0^\circ$	70	80	--	%	Note 1,5
Brightness		L	$\theta x = \theta y = 0^\circ$ ADJ=3.3V	270	340	--	cd/m ²	Note 1,2
Chromaticity	x_W	Center $\theta x = \theta y = 0^\circ$	0.259	0.309	0.359		Note 1,7	
	y_W		0.270	0.320	0.370			
	x_R		0.565	0.615	0.665			
	y_R		0.310	0.360	0.410			
	x_G		0.295	0.345	0.395			
	y_G		0.490	0.540	0.590			
	x_B		0.098	0.148	0.198			
	y_B		0.056	0.106	0.156			
Image sticking	tis	2 hours			2	Sec	Note 8	

The following optical specifications shall be measured in a darkroom or equivalent state (ambient luminance ≤ 1 lux, and at room temperature). The operation temperature is $25^\circ\text{C} \pm 2^\circ\text{C}$. The measurement method is shown in Note 1.

Note 1: The method of optical measurement:

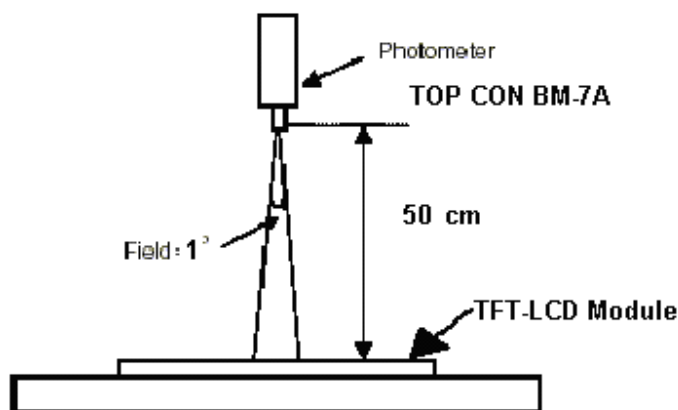

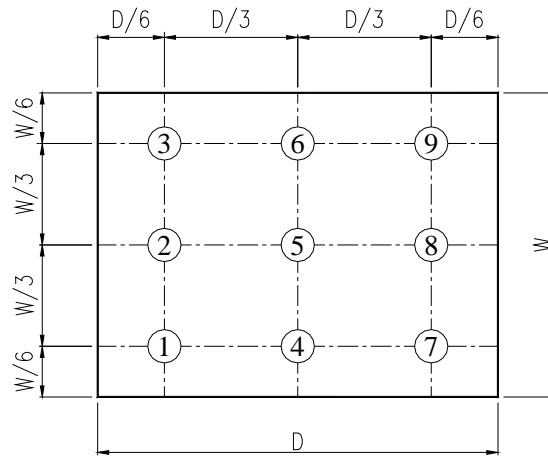

Note2: Measured at the center area of the panel and at the viewing angle of the $\theta_x = \theta_y = 0^\circ$

Note3: Definition of Contrast Ratio (CR):

$$CR = \frac{\text{Luminance with all pixels in white state}}{\text{Luminance with all pixels in Black state}}$$

Note4: Definition of Viewing Angle

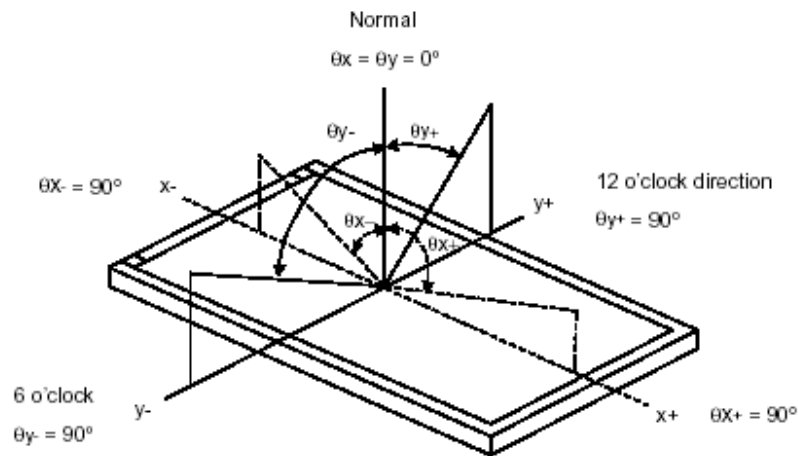

Note 5: Definition of Brightness Uniformity (B-uni):

$$B\text{-uni} = \frac{\text{Minimum luminance of 9 points}}{\text{Maximum luminance of 9 points}} \quad (\text{Note 5}).$$

Note6: Definition of Response Time:

The Response Time is set initially by defining the “Rising Time (Tr)” and the “Falling Time (Tf)” respectively. Tr and Tf are defined as following figure.

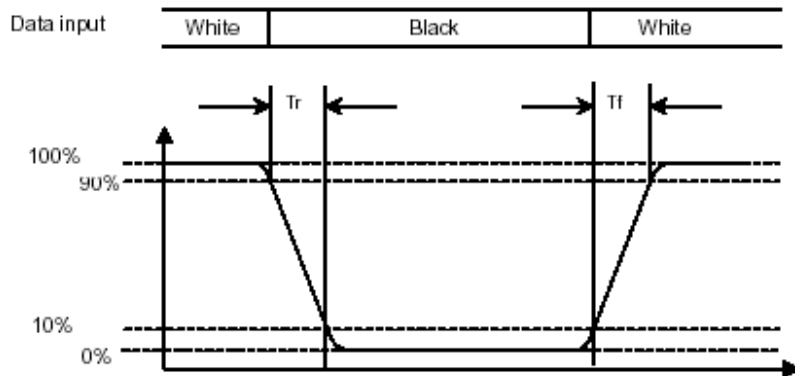
Note 7: Definition of Chromaticity:

The color coordinates (x_W, y_W) , (x_R, y_R) , (x_G, y_G) , and (x_B, y_B) are obtained with all pixels in the viewing field at white, red, green, and blue states, respectively.

Note 8: Definition of Image sticking (tis):

Continuously display the test pattern shown in the figure below for 2 hours. Then display a completely white screen. The previous image shall not persist more than 2 sec at 25 °C

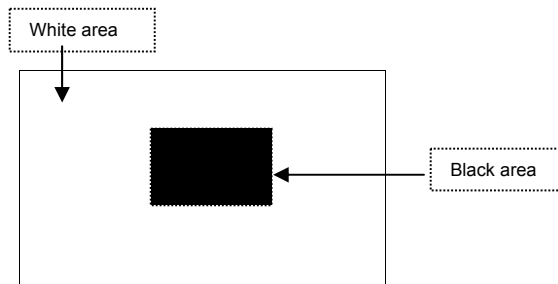

Image sticking pattern

11. CTP General specifications

11.1 CTP main feature

Item	Specification	Unit
Type	Transparent type projected capacitive touch panel	
Input mode	Human's finger	
Active area	91.5(H)(typ.) X 120.3 (V) (typ.)	mm
Resolution	Up to 2048 x 2048	
Transparency	≥ 85%	%
Haze	≤ 1.0%	%
Hardness	7H (min) [by JIS K5400]	Pencil hardness
Report rate	40~80	Points/sec
Response time	70	ms

11.2 CTP Absolute Maximum Rating

Symbol	Description	Min	Typ	Max	Unit	Notes
VDD	Supply voltage	-0.5	-	6.0	V	
VIO	DC input voltage	GND -0.5	-	VDD+0.5	V	
IMIO	Maximum input current	-25	-	50	mA	
ESD	Electrostatic discharge voltage	2000	-	-	V	

11.3 CTP Electrical Characteristic

Symbol	Description	Min	Typ	Max	Unit	Notes
VDD	Supply voltage	4.75	5	5.25	V	
I	Supply current	T.B.D	T.B.D	T.B.D	mA	At VDD=5V
ISLEEP	Sleep mode current	-	4	25	uA	At VDD=5V

11.4 CTP Pin Connections

No.	Name	I/O	Description
1	NC		No connection
2	SCL	I	I ² C Clock
3	SDA	I/O	I ² C Data
4	NC		No connection
5	INT	O	Interrupt active low, asserted to request start a new transaction
6	GND		Ground
7	VDD		Power supply Voltage
8	XRES	I	Active high external reset with internal pull down. Minimum of Pulse Width is 10us
9	NC		No connection

11.5 CTP Interface and Data Format (Slave address is 0x0AH)

Communication protocol: I²C

Clock frequency : 100k Hz

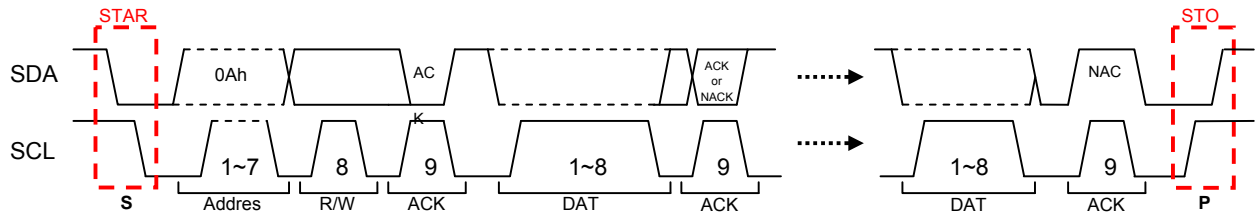

Report rate = $1 / T_{INT}$, it depends on properties of touch screen such as resistive value, channel number, thickness and material of cover lens, etc.

Note. 1. Use appropriate resistor value during high speed SCL clock.

Suggestion : Resistor recommendation : 1K Ω .

2. To reduce the noise from the power, we suggest you use the independent power for the touch panel (VDD)

11.6 Protocol

Read mode: Master-receiver, slave-transmitter.

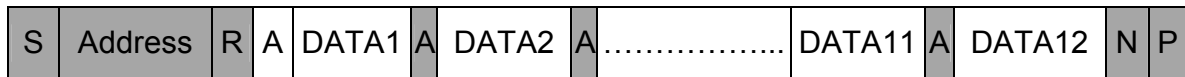

Write mode: Master-transmitter, slave-receiver

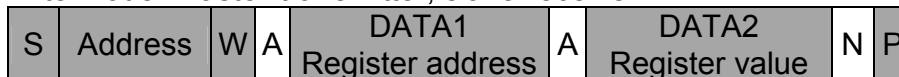

	From Master to Slave
	From Slave to Master

S	START condition
P	STOP condition
R	Data direction READ (SDA HIGH)
W	Data direction WRITE (SDA LOW)
A	Acknowledge (SDA LOW)
N	Not acknowledge (SDA HIGH)
Address	7-bit (0Ah)
DATA	8-bit

11.7 Report Packet

Single Touch

Each report packet contains 12 bytes. The single touch packet format is as follows:

	MSB							LSB
Byte 1	1	0	0	0	0	0	0	Status
Byte 2	0	0	0	0	A10	A9	A8	A7
Byte 3	0	A6	A5	A4	A3	A2	A1	A0
Byte 4	0	0	0	0	B10	B9	B8	B7
Byte 5	0	B6	B5	B4	B3	B2	B1	B0
Byte 6	0	P6	P5	P4	P3	P2	P1	P0
Byte 7 ~ Byte 12	0	0	0	0	0	0	0	0

Status: indicates the touch status: 1 for touch down and 0 for touch up.

A10 - A0: 11 bits of 1st direction raw data.

B10 - B0: 11 bits of 2nd direction raw data.

P6 – P0: 7 bits of finger pressure.

Byte 7~ Byte 12: Reserved.

Please be aware that A and B just represent 2 resolution directions of the touch panel. The reported coordinates are (0~2047, 0~2047), the bottom left is (0, 0).

11.8 Operating Mode Register

Register Address	Register Name	Bit7	Bit6	Bit5	Bit4	Bit3	Bit2	Bit1	Bit0	Default Value		
0x07	Operating Mode	Wakeup and Sleep								Wakeup / Sleep	0x01	
		0	0	0	0	0	0	0	0			
		Single touch, Gesture touch and Dual touch								Gesture	Dual	0x11
		0	0	0	1	0	0	0	0			
Get firmware version								0	0			
0	1	0	0	0	0	1	0					

Sleep: Write (0x07,0x00), the chip sleep and power saving.

Wakeup: Enable the I2C using SDA falling edge when PCAP7201 is on sleep state, and write (0x07,0x01) to wakeup the chip.

Single touch: Write (0x07,0x10).

Dual touch: Write (0x07,0x11).

Gesture touch: Write (0x07,0x12). Include the Slide, Rotate and Zoom gesture functions.

11.9 CTP Life Test

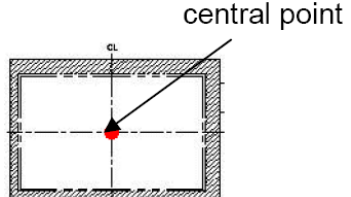
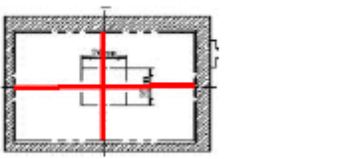
1	Point hitting life (no contact CTP)	> 1,000,000; Use 11mm diameter/copper column to knock on the same point twice per second under system operating.	
2	Line Drawing life (no contact CTP)	> 100,000; Use 11mm diameter/copper column to draw straight lines back and forth as the following red lines at the speed of 100mm/sec under system operating.	

12. Appearance Specification

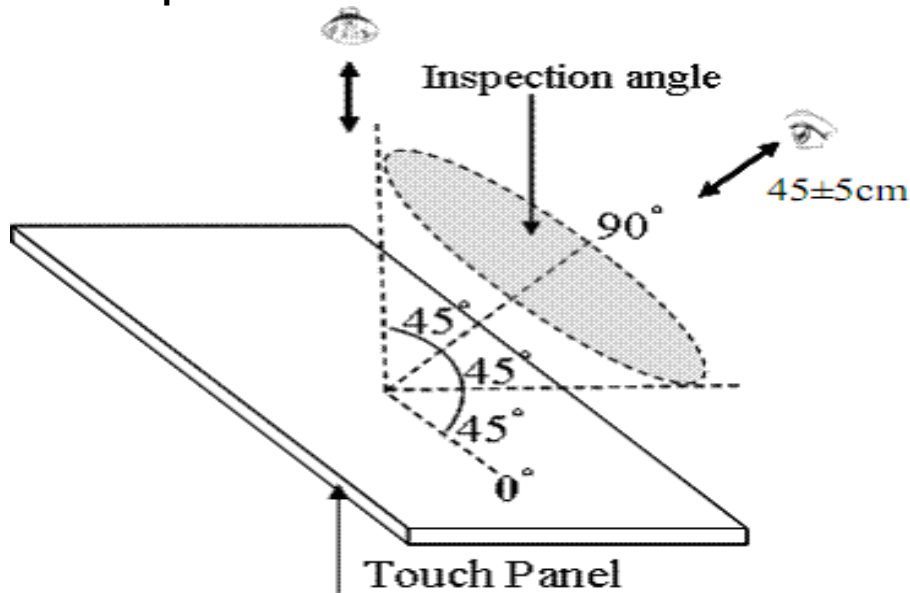

12.1 Environment : $22 \pm 3^{\circ}\text{C}$, Inspection distance : $45 \pm 5\text{cm}$.

12.2 Angle of Visual : $90^{\circ} \pm 45^{\circ}$.

12.3 Light illumination: 800 Lux.

12.4 Inspection top side and bottom side view area duration : 5s

12.5 Inspection four edge ink area duration:

12.6 Specification

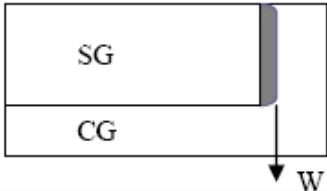
Item	Specification	
Circular Defects	Diameter(mm)	Spec
	$D \leq 0.2\text{mm}$	No quantity limit
	$0.2 < D \leq 0.4 \text{ mm}$	Max 5 defect
	$0.4 \text{ mm} < D$	Reject
	The minimum distance of defects must be above 10mm. The particle will be ignored when it is removable by cleaning.	
Bubble Defects	Diameter(mm)	Spec
	$D \leq 0.1\text{mm}$	No quantity limit
	$0.1 < D \leq 0.2 \text{ mm}$	Max 5 defect
	$0.2 \text{ mm} < D$	Reject
	The minimum distance of defects must be above 10mm.	
Linear Object	Width(W)/Length(L)(mm)	Spec
	$W \leq 0.08 \text{ mm} , L \leq 2.0 \text{ mm}$	No quantity limit
	$W \leq 0.08 \text{ mm} , L \leq 8.0 \text{ mm}$	Max 3 defect
	$W \leq 0.2\text{mm} , L \leq 2.0 \text{ mm}$	Max 3 defect
	The minimum distance of defects must be above 10mm. The liner object will be ignored when it is removable by cleaning.	
Scratch	Width(W)/Length(L)(mm)	Spec
	$W \leq 0.05, L \leq 10.0\text{mm}$	No quantity limit
	$0.05 < W \leq 0.1\text{mm}, L \leq 10.0\text{mm}$	Max 5 defect
	$0.1 \text{ mm} < W, 10.0 \text{ mm} < L$	Reject
	The minimum distance of defects must be above 10mm.	
Pin hole (Ink Area)	Diameter(mm)	Spec
	$D \leq 0.1\text{mm}$	No quantity limit
	$0.1 < D \leq 0.2 \text{ mm}$	Max 5 defect
	$0.2\text{mm} < D$	Reject
	The minimum distance of defects must be above 10mm.	
UV Glue extension (Bottom View)	Width(W) (mm)	
	$D \leq 2\text{mm}$	
		
<Remark> D=Diameter W=Width L=Length		

13. QUALITY ASSURANCE

13.1 Test Condition

13.1.1 Temperature and Humidity(Ambient Temperature)

Temperature : $25 \pm 5^{\circ}\text{C}$

Humidity : $65 \pm 5\%$

13.1.2 Operation

Unless specified otherwise, test will be conducted under function state.

13.1.3 Container

Unless specified otherwise, vibration test will be conducted to the product itself without putting it in a container.

13.1.4 Test Frequency

In case of related to deterioration such as shock test. It will be conducted only once.

13.1.5 Test Method

No.	Reliability Test Item & Level	Test Level
1	High Temperature Operation Test	T=50°C,200hrs
2	Low Temperature Operation Test	T=0°C,200hrs
3	Thermal Cycling Test (No operation)	-20°C → +60°C,10 Cycles 30 min 30 min
4	Electrostatic Discharge Test (No operation)	TBD

14. CTP LCM PRODUCT LABEL DEFINE

CTP LCM Product Label style:

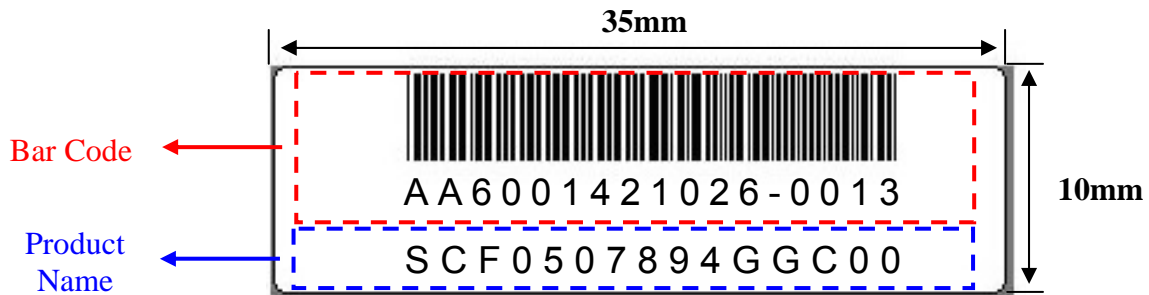

Bar Code Define:

A A 6 0014 2 10 26-0013

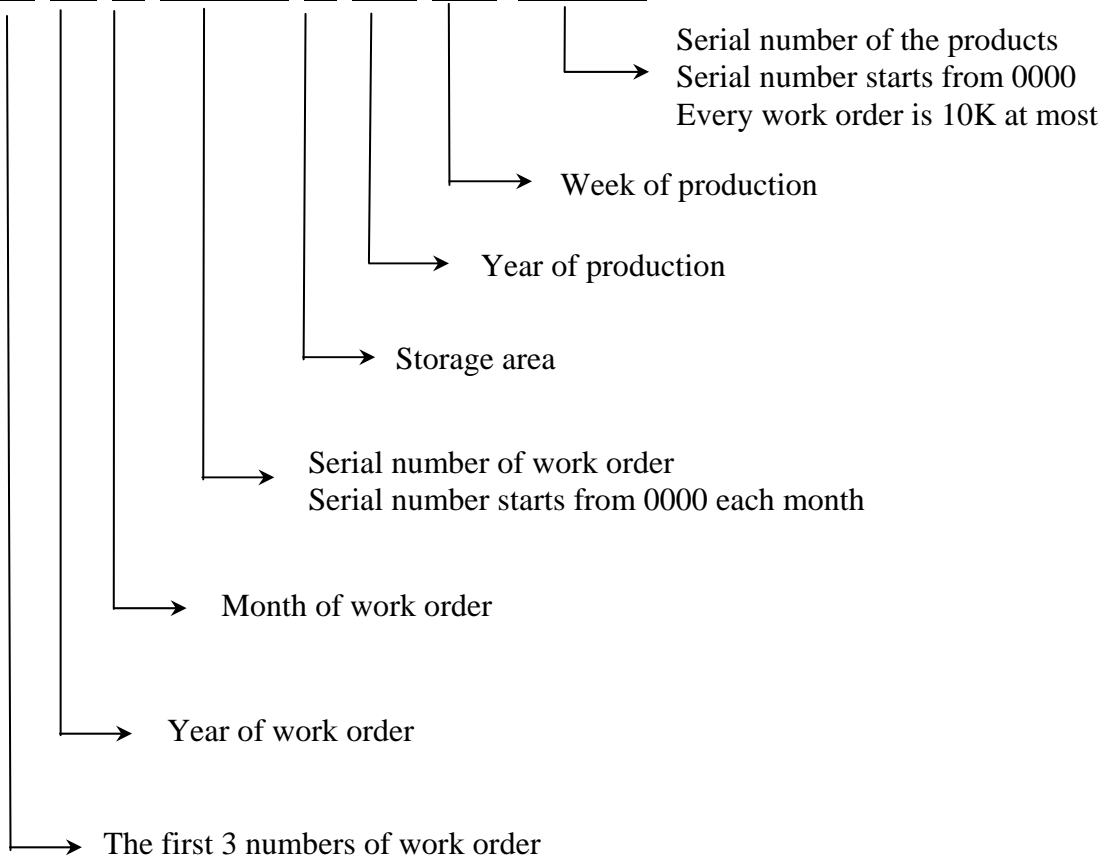

Product Name Define:

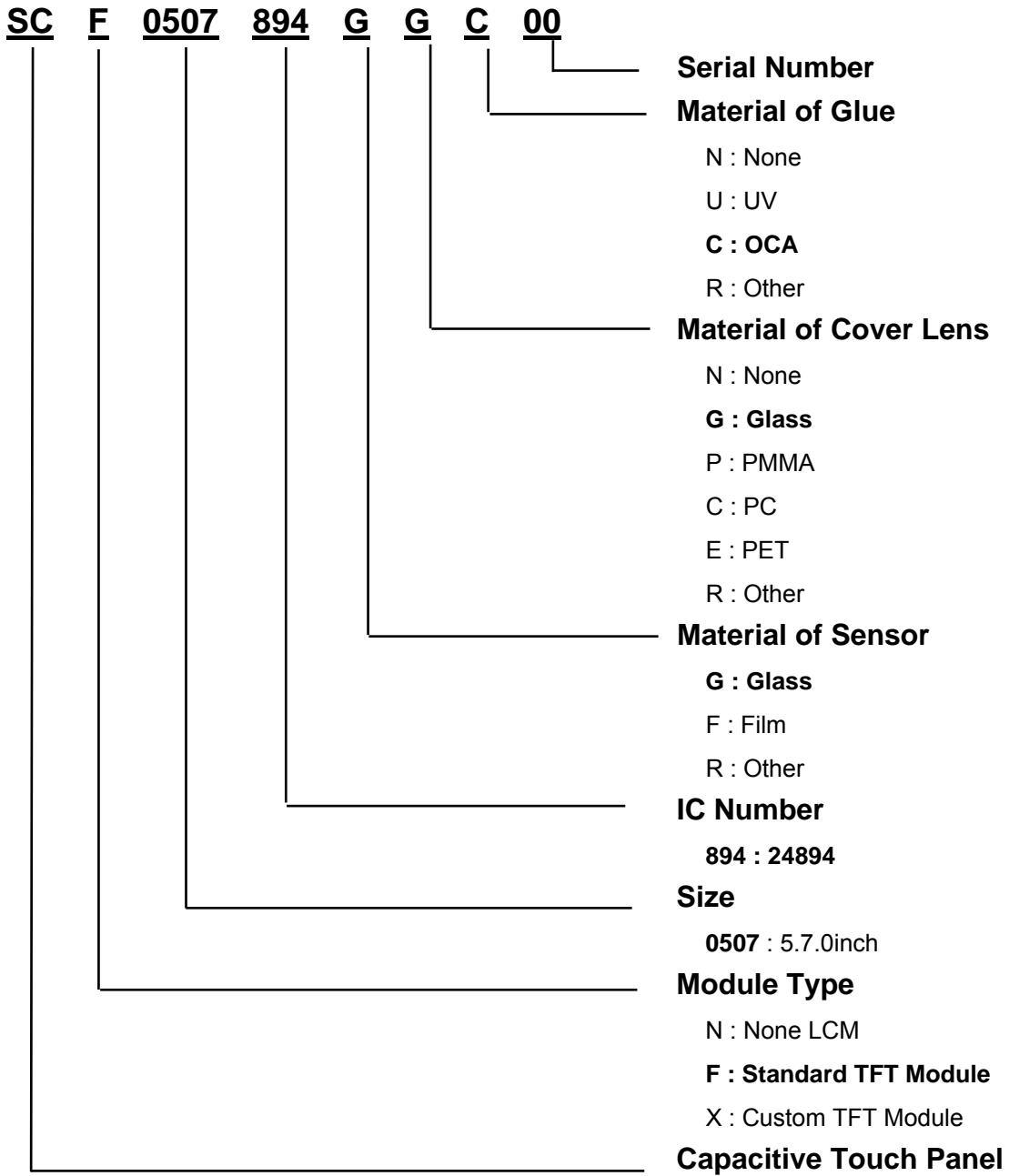

15. PRECAUTION FOR USING LCM

1. LIQUID CRYSTAL DISPLAY (LCD)

LCD is made up of glass, organic sealant, organic fluid, and polymer based polarizers. The following precautions should be taken when handling,

- (1). Keep the temperature within range of use and storage. Excessive temperature and humidity could cause polarization degradation, polarizer peel off or bubble.
- (2). Do not contact the exposed polarizers with anything harder than an HB pencil lead. To clean dust off the display surface, wipe gently with cotton, chamois or other soft material soaked in petroleum benzin.
- (3). Wipe off saliva or water drops immediately. Contact with water over a long period of time may cause polarizer deformation or color fading, while an active LCD with water condensation on its surface will cause corrosion of ITO electrodes.
- (4). Glass can be easily chipped or cracked from rough handling, especially at corners and edges.
- (5). Do not drive LCD with DC voltage.

2. Liquid Crystal Display Modules

2.1 Mechanical Considerations

LCM are assembled and adjusted with a high degree of precision. Avoid excessive shocks and do not make any alterations or modifications. The following should be noted.

- (1). Do not tamper in any way with the tabs on the metal frame.
- (2). Do not modify the PCB by drilling extra holes, changing its outline, moving its components or modifying its pattern.
- (3). Do not touch the elastomer connector, especially insert an backlight panel (for example, EL).
- (4). When mounting a LCM make sure that the PCB is not under any stress such as bending or twisting. Elastomer contacts are very delicate and missing pixels could result from slight dislocation of any of the elements.
- (5). Avoid pressing on the metal bezel, otherwise the elastomer connector could be deformed and lose contact, resulting in missing pixels.

2.2. Static Electricity

LCM contains CMOS LSI's and the same precaution for such devices should apply, namely

- (1). The operator should be grounded whenever he/she comes into contact with the module. Never touch any of the conductive parts such as the LSI pads, the copper leads on the PCB and the interface terminals with any parts of the human body.
- (2). The modules should be kept in antistatic bags or other containers resistant to static for storage.
- (3). Only properly grounded soldering irons should be used.
- (4). If an electric screwdriver is used, it should be well grounded and shielded from commutator sparks.

(5) The normal static prevention measures should be observed for work clothes and working benches; for the latter conductive (rubber) mat is recommended.

(6). Since dry air is inductive to statics, a relative humidity of 50-60% is recommended.

2.3 Soldering

- (1). Solder only to the I/O terminals.
- (2). Use only soldering irons with proper grounding and no leakage.
- (3). Soldering temperature : $280^{\circ}\text{C} \pm 10^{\circ}\text{C}$
- (4). Soldering time: 3 to 4 sec.
- (5). Use eutectic solder with resin flux fill.
- (6). If flux is used, the LCD surface should be covered to avoid flux spatters. Flux residue should be removed after wards.

2.4 Operation

- (1). The viewing angle can be adjusted by varying the LCD driving voltage V_0 .
- (2). Driving voltage should be kept within specified range; excess voltage shortens display life.
- (3). Response time increases with decrease in temperature.
- (4). Display may turn black or dark blue at temperatures above its operational range; this is (however not pressing on the viewing area) may cause the segments to appear "fractured".
- (5). Mechanical disturbance during operation (such as pressing on the viewing area) may cause the segments to appear "fractured".

2.5 Storage

If any fluid leaks out of a damaged glass cell, wash off any human part that comes into contact with soap and water. Never swallow the fluid. The toxicity is extremely low but caution should be exercised at all the time.

2.6 Limited Warranty

Unless otherwise agreed between DATA IMAGE and customer, DATA IMAGE will replace or repair any of its LCD and LCM which is found to be defective electrically and visually when inspected in accordance with DATA IMAGE acceptance standards, for a period on one year from date of shipment. Confirmation of such date shall be based on freight documents. The warranty liability of DATA IMAGE is limited to repair and/or replacement on the terms set forth above. DATA IMAGE will not responsible for any subsequent or consequential events.

Confidential Document
16. OUTLINE DRAWING

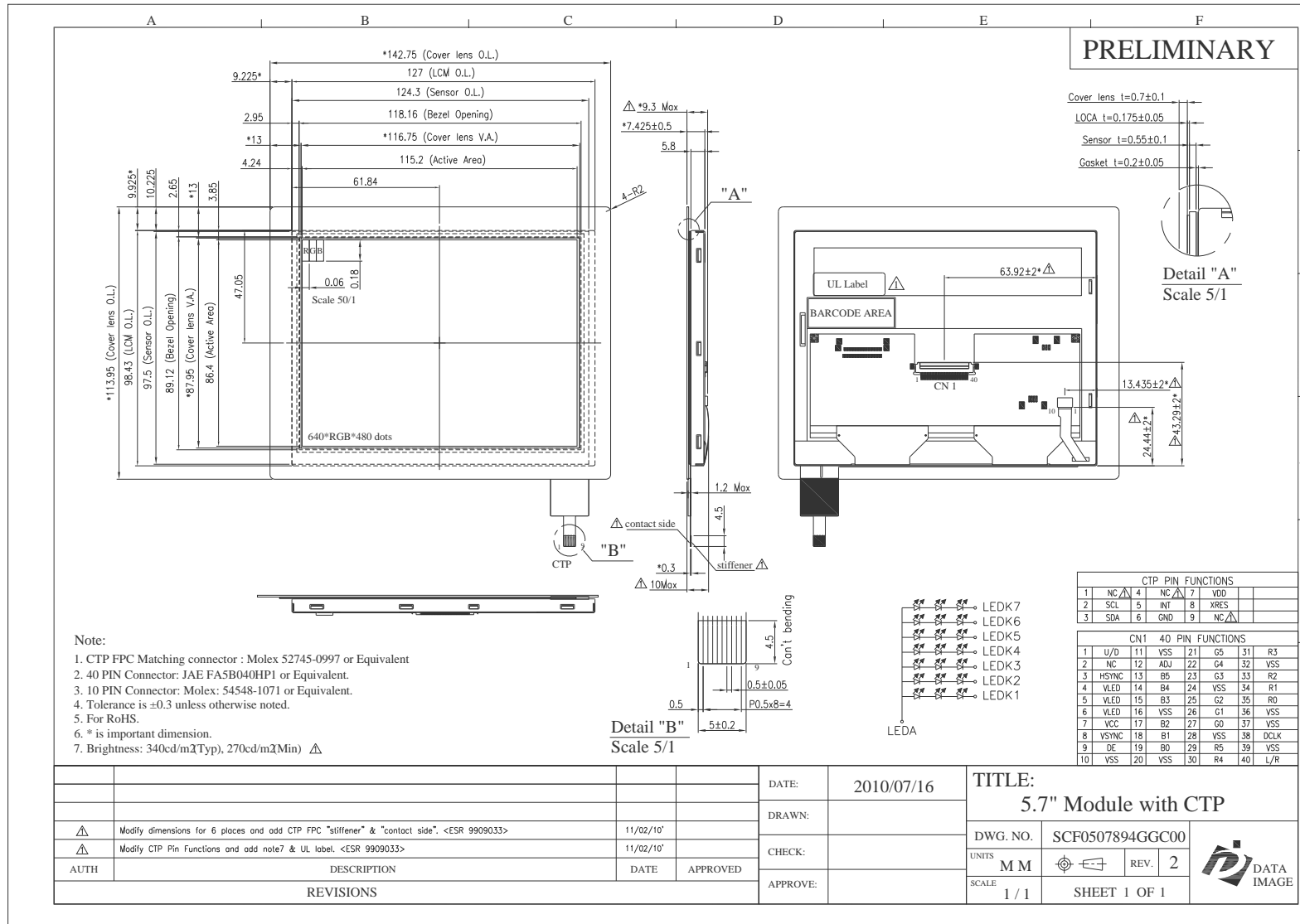

17.PACKAGE INFORMATION

TBD