

TFT-Display Datenblatt

Modell SCF0507894GGC01

Kurzdaten

Hersteller	Data Image
Diagonale	5,7" / 14,5cm
Format	4:3
Auflösung	640:480
Backlight	LED/ 340cd/m ²
Interface	TTL
Touchscreen	ja
Temperatur	-20...+70°C (Betrieb)



DATA IMAGE CORPORATION

TFT Module Specification

Preliminary

ITEM NO.: SCF0507894GGC01

Table of Contents

1. COVER & CONTENTS	1
2. RECORD OF REVISION	2
3. APPLICATION.....	3
4. GENERAL SPECIFICATIONS	3
5. ABSOLUTE MAXIMUM RATINGS	3
6. ELECTRICAL CHARACTERISTICS.....	3
7. TIMING SPECIFICATIONS	4
8. OPTICAL CHARACTERISTIC	8
9. PIN CONNECTIONS	10
10. BLOCK DIAGRAM	12
11. CTP GENERAL SPECIFICATIONS.....	13
12. APPEAARANCE SEPCIFICATION.....	17
13. QUALITY ASSURANCE.....	19
14. CTP LCM PRODUCT LABEL DEFINE	20
15. PRECAUTIONS IN USE LCM.....	22
16. OUTLINE DRAWING.....	23
17. PACKAGE INFORMATION	24

Approved by 	Checked by QC. Div	Checked by Pro. Div	Checked by R&D. Div.	Drawn by
	Final Revision: 1	Sheet Code:	Issued Date: 2011/01/11	Total Page: 24

3. APPLICATION

Digital equipments which need color display, such as P.O.S, medical equipments and industrial equipments.

4. GENERAL SPECIFICATIONS

Composition: 5.7 inch QVGA resolution display with a projected Capacitive Touch Panel (CTP).
Interface : 18bit parallel RGB for panel and I²C for the CTP.

Parameter	Specifications	Unit
Display resolution	(320X R.G.B) (W) x 240(H)	dot
Active area	115.2(W) x 86.4(H)	mm
Screen size	5.7(Diagonal)	inch
Dot pitch	0.12(W) x 0.36(H)	mm
Color configuration	R.G.B. Stripe	
Overall dimension	142.75 (W) x 113.95(H) x14.63(D)	mm
Weight	T.B.D	g
Surface treatment	Clear	
View Angle direction	12 o'clock	
Our components and processes are compliant to RoHS standard		

5. ABSOLUTE MAXIMUM RATINGS

GND=0V

Parameter	Symbol	MIN.	MAX.	Unit	Remark
Power supply voltage	V _{CC}	-0.3	+7.0	V	
Logic input voltage	V _I	-0.3	V _{CC} +0.3	V	
Operating temperature	Top	-20	70	°C	Ambient temperature
Storage temperature	T _{st}	-25	80	°C	Ambient temperature

6. ELECTRICAL CHARACTERISTICS

GND=0V, Ta=25°C

Parameter	Symbol	MIN.	Typ.	MAX.	Unit	Remark
Power Supply voltage	V _{CC}	+3.0	+3.3	+3.6	V	
Power Supply Current	I _{CC}		130	150	mA	V _{CC} =3.3V
"H" level logical input voltage	V _{IH}	0.7V _{CC}	--	3.6	V	
"L" level logical input voltage	V _{IL}	0V	--	0.3V _{CC}	V	
LED current	I _L	--	140	--	mA	
VLED voltage	V _L	--	10.2	10.8	V	
LED dice Life Time		10000	25000	--	hr	Note 1:

Note 1: The "LED dice life time" is defined as the LED dice brightness decrease to 50% original brightness that the ambient temperature is 22°C and LED dice current 20mA.

7. TIMING SPECIFICATIONS

7.1 LCM Input Signal Timing Specifications

Parameter		Symbol	MIN.	TYP.	MAX.	Unit	Remarks
CLK	Frequency	1/Tc		6.41		MHz	
	Duty ratio	Th/Tc	40	50	60	%	
DATA	Setup time	Tds	12			ns	
	Hold time	Tdh	12			ns	
Horizontal synchronizing	Period	TH	--	408	--	Clock	
	Pulse width	THp	--	30	--	Clock	
	Horizontal period	THd	--	320	--	Clock	
	Blank porch	THb	--	38	--	Clock	
	Front porch	THf	--	20	--	Clock	
Vertical synchronizing	Period	TV	--	262	--	Line	
	Pulse width	TVp	--	4	--	Line	
	Vertical period	TVd	--	240	--	Line	
	Blank porch	TVb	--	15	--	Line	
	Front porch	TVf	--	3	--	Line	

Note:

In case of using the slow frequency, the deterioration of display flicker etc may occur.
The timing characteristics are basically fixed as above.

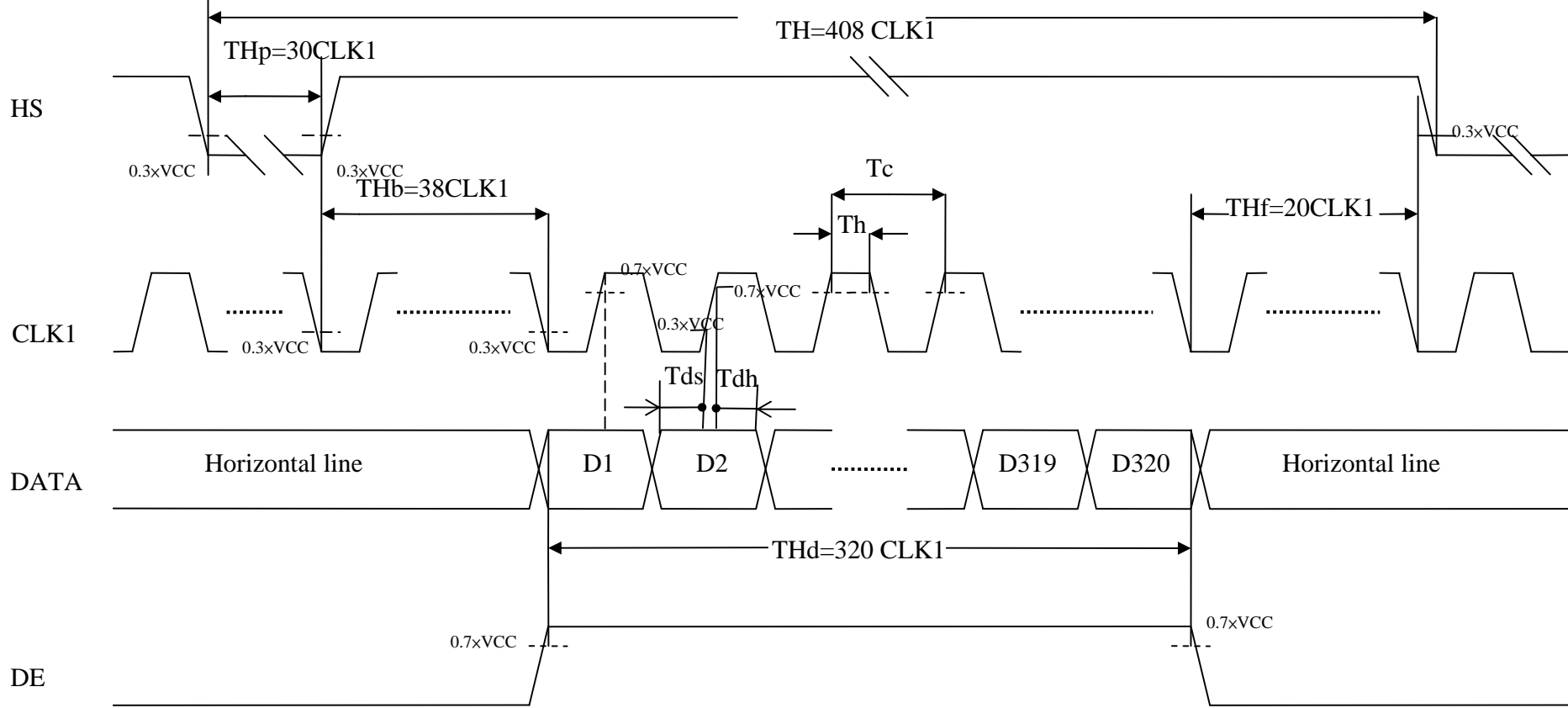

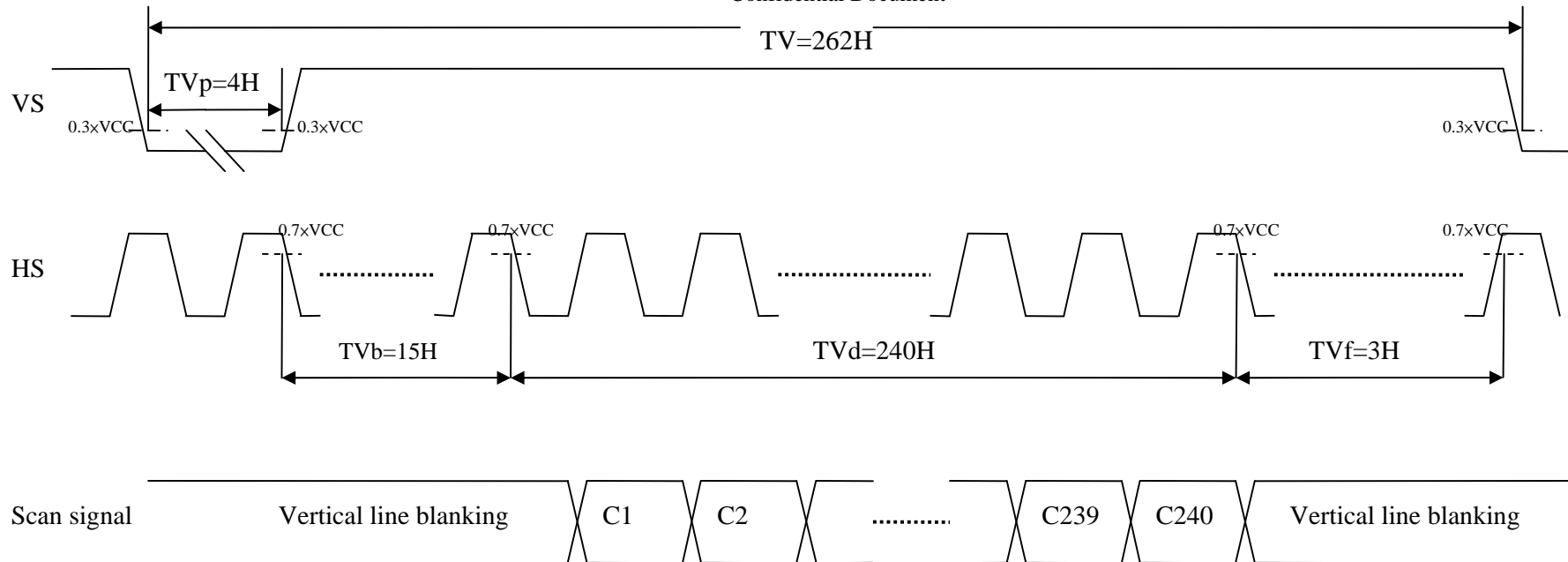

7.2 LCM Power Off/On Sequence Timing

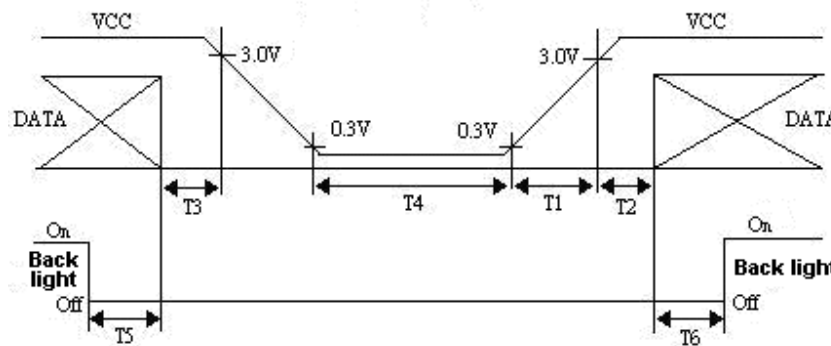

Timing Specifications:

- $0 < T1 \leq 15mS$
- $T2 > 0.5S$
- $0 < T3 \leq 0.1S$
- $T4 > 1S$
- $T5 > 0.1S$
- $T6 > 0.1S$

7.3 LCM Color Data Input Assignment

		Data Signal																	
		Red						Green						Blue					
Color		R5	R4	R3	R2	R1	R0	G5	G4	G3	G2	G1	G0	B5	B4	B3	B2	B1	B0
Basic Colors	Black	0	0	0	0	0	0	0	0	0	0	0	0	0	0	0	0	0	0
	Red	1	1	1	1	1	1	0	0	0	0	0	0	0	0	0	0	0	0
	Green	0	0	0	0	0	0	1	1	1	1	1	1	0	0	0	0	0	0
	Blue	0	0	0	0	0	0	0	0	0	0	0	0	1	1	1	1	1	1
	Cyan	0	0	0	0	0	0	1	1	1	1	1	1	1	1	1	1	1	1
	Magenta	1	1	1	1	1	1	0	0	0	0	0	0	1	1	1	1	1	1
	Yellow	1	1	1	1	1	1	1	1	1	1	1	1	0	0	0	0	0	0
	White	1	1	1	1	1	1	1	1	1	1	1	1	1	1	1	1	1	1
Gray Scale of Red	Red(0) / Dark	0	0	0	0	0	0	0	0	0	0	0	0	0	0	0	0	0	0
	Red(1)	0	0	0	0	0	1	0	0	0	0	0	0	0	0	0	0	0	0
	Red(2)	0	0	0	0	1	0	0	0	0	0	0	0	0	0	0	0	0	0
	:	:	:	:	:	:	:	:	:	:	:	:	:	:	:	:	:	:	:
	:	:	:	:	:	:	:	:	:	:	:	:	:	:	:	:	:	:	:
	Red(61)	1	1	1	1	0	1	0	0	0	0	0	0	0	0	0	0	0	0
	Red(62)	1	1	1	1	1	0	0	0	0	0	0	0	0	0	0	0	0	0
	Red(63)	1	1	1	1	1	1	0	0	0	0	0	0	0	0	0	0	0	0
Gray Scale of Green	Green(0)/ Dark	0	0	0	0	0	0	0	0	0	0	0	0	0	0	0	0	0	0
	Green(1)	0	0	0	0	0	0	0	0	0	0	0	1	0	0	0	0	0	0
	Green(2)	0	0	0	0	0	0	0	0	0	0	1	0	0	0	0	0	0	0
	:	:	:	:	:	:	:	:	:	:	:	:	:	:	:	:	:	:	:
	:	:	:	:	:	:	:	:	:	:	:	:	:	:	:	:	:	:	:
	Green(61)	0	0	0	0	0	0	1	1	1	1	0	1	0	0	0	0	0	0
	Green(62)	0	0	0	0	0	0	1	1	1	1	1	0	0	0	0	0	0	0
	Green(63)	0	0	0	0	0	0	1	1	1	1	1	1	0	0	0	0	0	0
Gray Scale of Blue	Blue(0) / Dark	0	0	0	0	0	0	0	0	0	0	0	0	0	0	0	0	0	0
	Blue (1)	0	0	0	0	0	0	0	0	0	0	0	0	0	0	0	0	0	1
	Blue (2)	0	0	0	0	0	0	0	0	0	0	0	0	0	0	0	0	1	0
	:	:	:	:	:	:	:	:	:	:	:	:	:	:	:	:	:	:	:
	:	:	:	:	:	:	:	:	:	:	:	:	:	:	:	:	:	:	:
	Blue (61)	0	0	0	0	0	0	0	0	0	0	0	0	1	1	1	1	1	0
	Blue (62)	0	0	0	0	0	0	0	0	0	0	0	0	1	1	1	1	1	0
	Blue (63)	0	0	0	0	0	0	0	0	0	0	0	0	1	1	1	1	1	1

Correspondence between Data and Display Position

	S960	S959	S958	S957	S956	S955	S954	S953	-----	S002	S001
C001	B320	G320	R320	B319	G319	R319	B318	G318		G001	R001
C240	B320	G320	R320	B319	G319	R319	B318	G318		G001	R001

8. OPTICAL CHARACTERISTIC

8.1. Specification:

Item	Symbol	Condition	Min.	Typ.	Max.	Unit	Remark	
Response time	Rise	Tr	$\theta=0^\circ$	-	15	30	ms	Note 4
	Fall	Tf		-	35	50	ms	
Contrast ratio		CR	At optimized viewing angle		300	350		Note 5
Viewing angle	Top	θ_{y+}	CR \geq 5	60	70	-	Deg.	Note 6
	Bottom	θ_{y-}		40	50	-		
	Left	θ_{x-}		60	70	-		
	Right	θ_{x+}		60	70	-		
Brightness			$\theta=0^\circ$	300	340	--	cd/m ²	Note 7
Uniformity				75	--		%	Note 9
White chromaticity	X	$\theta=0^\circ$	0.25	0.30	0.35		Note 7	
	y		0.30	0.35	0.40			

Note 1: Ambient temperature =25°C. LED current = 140 mA..

Note 2: To be measured in the dark room.

Note 3: To be measured on the center area of panel with a viewing cone of 1° by Topcon luminance meter BM-7A, after 3 minutes operation.

Note 4: Definition of response time:

The output signals of photo-detector are measured when the input signals are changed from “white” to “black”(rising time) and from “black” to “white”(falling time),respectively. The response time is defined as the time interval between the 10% and 90% of amplitudes.

Refer to figure as shown below.

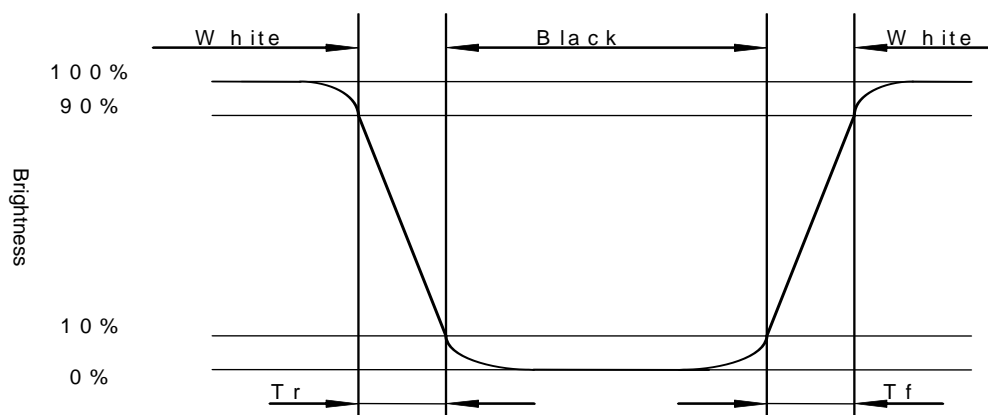

Note5: Definition of contrast ratio:

Contrast ratio is calculated with the following formula.

$$\text{Contrast ratio (CR)} = \frac{\text{Photo-detector output when LCD is at "White" state}}{\text{Photo-detector output when LCD is at "Black" state}}$$

Note 6. Definition of viewing angle:
Refer to figure as below.

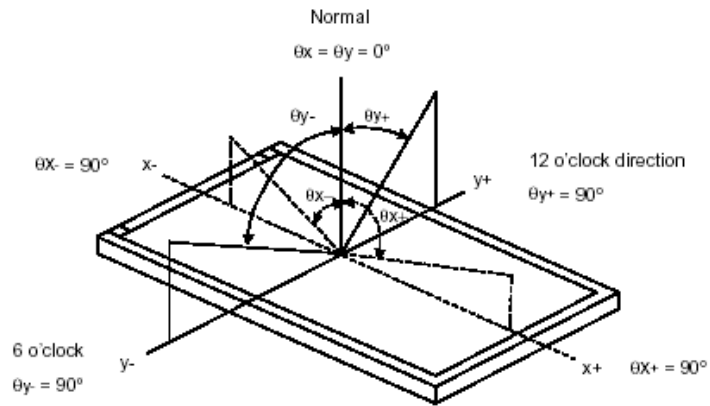

Note 7. Measured at the center area of the panel when all the input terminals of LCD panel are electrically opened.

Note8: The method of optical measurement:

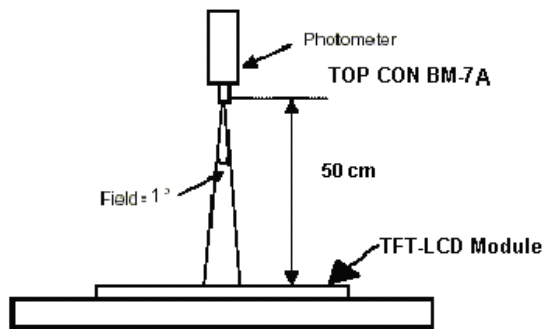

Note9: Definition of Brightness Uniformity (Buni):

Luminance Measuring Points

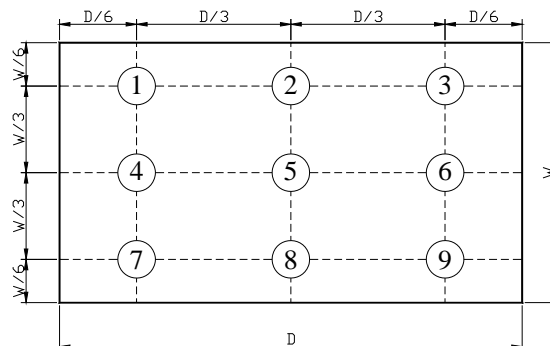

$$B\text{-uni} = \frac{\text{Minimum luminance of 9 points}}{\text{Maximum luminance of 9 points}}$$

9. PIN CONNECTIONS

9.1 Input Pins Connection (to TTL571 control board)

Pin No	Symbol	Function	Remark
1	GND	Ground for logic circuit	
2	CLK1	Data sampling clock	
3	HS (HSYNC)	Horizontal synchronous signal	
4	VS (VSYNC)	Vertical synchronous signal	
5	GND	Ground for logic circuit	
6	R0	Red pixel data(LSB)	
7	R1	Red pixel data	
8	R2	Red pixel data	
9	R3	Red pixel data	
10	R4	Red pixel data	
11	R5	Red pixel data(MSB)	
12	GND	Ground for logic circuit	
13	G0	Green pixel data(LSB)	
14	G1	Green pixel data	
15	G2	Green pixel data	
16	G3	Green pixel data	
17	G4	Green pixel data	
18	G5	Green pixel data(MSB)	
19	GND	Ground for logic circuit	
20	B0	Blue pixel data(LSB)	
21	B1	Blue pixel data	
22	B2	Blue pixel data	
23	B3	Blue pixel data	
24	B4	Blue pixel data	
25	B5	Blue pixel data(MSB)	
26	GND	Ground for logic circuit	
27	DE	Data Enable (connected to GND, if sync mode)	
28	VCC	Power Supply : +3.3V	
29	VCC	Power Supply : +3.3V	
30	R/L	Horizontal display mode select signal Left / Right Scan control input	Note 2
31	U/D	Vertical display mode select signal Up / Down Scan control input	Note 2
32	NC	No Connection	
33	GND	Ground for logic circuit	

Note 1: The horizontal display start timing is settled in accordance with a rising timing of DE signal.
Don't keep DE at "High" during operation.

Note 2:

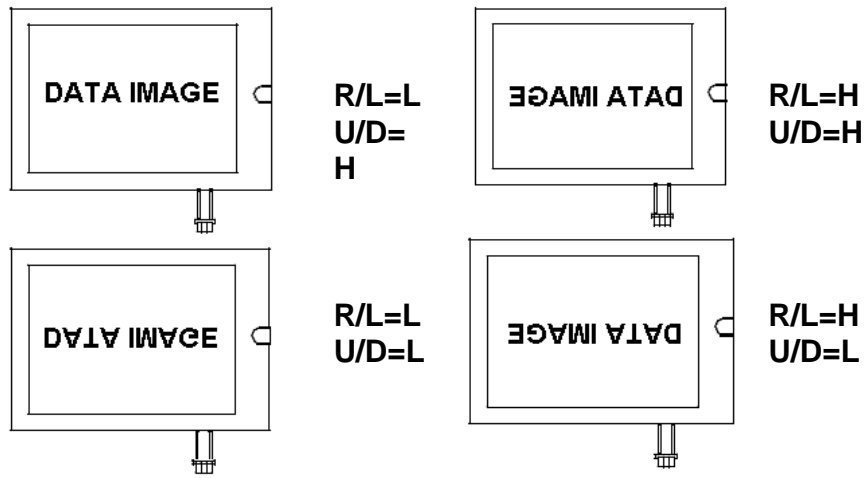

10. BLOCK DIAGRAM

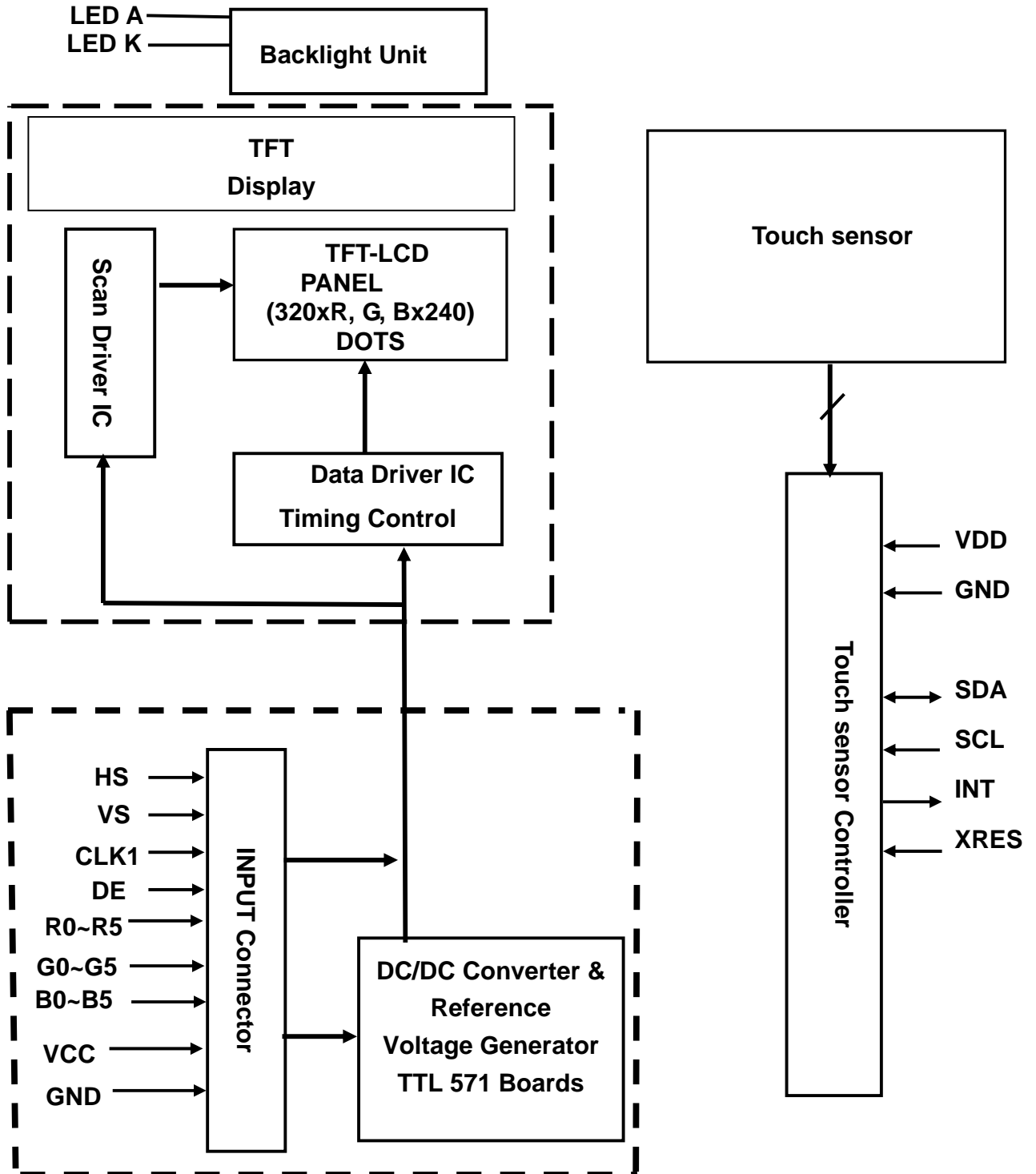

11. CTP GENERAL SPECIFICATIONS

11.1 CTP main feature

Item	Specification	Unit
Type	Transparent type projected capacitive touch panel	
Input mode	Human's finger	
Active area	91.5(H)(typ.) X 120.3 (V) (typ.)	mm
Resolution	Up to 2048 x 2048 (Configurable)	
Transparency	≥ 85%	%
Haze	≤ 1.0%	%

11.2 CTP Absolute Maximum Rating

Symbol	Description	Min	Typ.	Max	Unit	Notes
VDD	Supply voltage	-0.5	-	6.0	V	
VIO	DC input voltage	GND -0.5	-	VDD+0.5	V	
IMIO	Maximum input current	-25	-	50	mA	
ESD	Electrostatic discharge voltage	2000	-	-	V	Human Body Model ESD.

11.3 CTP Electrical Characteristic

Symbol	Description	Min	Typ.	Max	Unit	Notes
VDD	Supply voltage	4.75	5	5.25	V	
I	Supply current	-	T.B.D	-	mA	At VDD=5V

11.4 CTP Pin Connections

No.	Name	I/O	Description
1	NC		No connection
2	SCL	I	I ² C Clock
3	SDA	I/O	I ² C Data
4	NC		No connection
5	INT	O	Interrupt active low, asserted to request start a new transaction
6	GND		Ground
7	VDD		Power supply Voltage
8	XRES	I	Active high external reset with internal pull down. Minimum of Pulse Width is 10us
9	NC		No connection

11.5 CTP Interface and Data Format (Slave address is 0x0AH)

Communication protocol: I²C

Clock frequency : 400Khz

Report Rate : 40 ~ 80 points/sec

Response Time : 70 mS

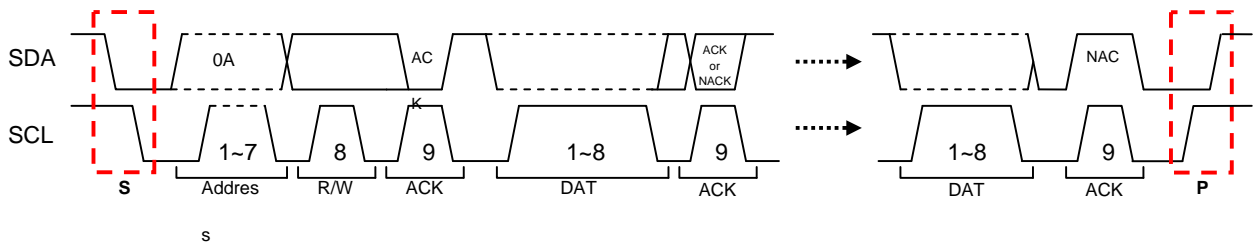

Report rate = $1 / T_{INT}$, it depends on properties of touch screen such as resistive value, channel number, thickness and material of cover lens, etc.

11.6 Protocol

Read mode: Master-receiver, slave-transmitter.

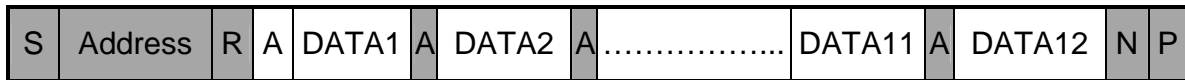

Write mode: Master-transmitter, slave-receiver

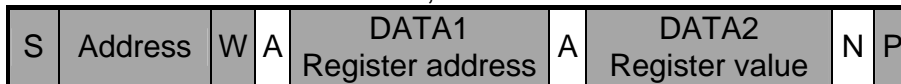

	From Master to Slave
	From Slave to Master

S	START condition
P	STOP condition
R	Data direction READ (SDA HIGH)
W	Data direction WRITE (SDA LOW)
A	Acknowledge (SDA LOW)
N	Not acknowledge (SDA HIGH)
Address	7-bit (0Ah)
DATA	8-bit

11.7 Report Packet

Single Touch

Each report packet contains 12 bytes. The single touch packet format is as follows:

	MSB							LSB
Byte 1	1	0	0	0	0	0	0	Status
Byte 2	0	0	0	0	A10	A9	A8	A7
Byte 3	0	A6	A5	A4	A3	A2	A1	A0
Byte 4	0	0	0	0	B10	B9	B8	B7
Byte 5	0	B6	B5	B4	B3	B2	B1	B0
Byte 6	0	P6	P5	P4	P3	P2	P1	P0
Byte 7 ~ Byte 12	0	0	0	0	0	0	0	0

Status: indicates the touch status: 1 for touch down and 0 for touch up.

A10 - A0: 11 bits of 1st direction raw data.

B10 - B0: 11 bits of 2nd direction raw data.

P6 – P0: 7 bits of finger pressure.

Byte 7~ Byte 12: Reserved.

Please be aware that A and B just represent 2 resolution directions of the touch panel. The reported coordinates are (0~2047, 0~2047), the bottom left is (0, 0).

11.8 Multi Touch – Rectangle

The multi-touch rectangle packet format is as follows:

Byte 1	Byte 2	Byte 3	Byte 4
0x0A	0x0A	0x34	Status

	MSB							LSB
Byte 5	0	0	0	0	A10	A9	A8	A7
Byte 6	0	A6	A5	A4	A3	A2	A1	A0
Byte 7	0	0	0	0	B10	B9	B8	B7
Byte 8	0	B6	B5	B4	B3	B2	B1	B0
Byte 9	0	0	0	0	C10	C9	C8	C7
Byte 10	0	C6	C5	C4	C3	C2	C1	C0
Byte 11	0	0	0	0	D10	D9	D8	D7
Byte 12	0	D6	D5	D4	D3	D2	D1	D0

Status: indicates the touch status: 0xA1 for touch down and 0xA0 for touch up. A10 - A0: 11 bits of the P1 1st direction raw data.

B10 - B0: 11 bits of the P1 2nd direction raw data.

C10 - C0: 11 bits of the P2 1st direction raw data. D10 - D0: 11 bits of the P2 2nd direction raw data.

When you touch two points, the report points are (min(X1,X2),min(Y1,Y2)) and (max(X1,X2), max(Y1,Y2)).

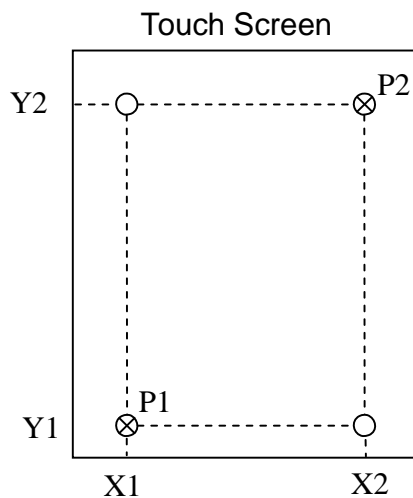

11.9 Operating Mode Register

Register Address	Register Name	Bit7	Bit6	Bit5	Bit4	Bit3	Bit2	Bit1	Bit0	Default Value		
0x07	Operating Mode	Wakeup and Sleep								Wakeup / Sleep	0x01	
		Single touch, Gesture touch and Dual touch								Gesture	Dual	0x11
		Get firmware version										
		0	0	0	0	0	0	0	0			
		0	0	0	1	0	0					
		0	1	0	0	0	1	0	0			

Sleep: Write (0x07,0x00), the chip sleep and power saving.

Wakeup: Enable the I2C using SDA falling edge when PCAP7201 is on sleep state, and write (0x07,0x01) to wakeup the chip.

Single touch: Write (0x07,0x10).

Dual touch: Write (0x07,0x11).

Gesture touch: Write (0x07,0x12). Include the Slide, Rotate and Zoom gesture functions.

11.9 CTP Life Test

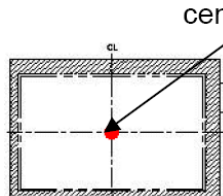
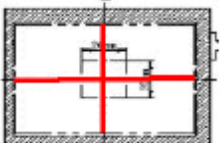
1	Point hitting life (no contact CTP)	> 1,000,000; Use 11mm diameter/copper column to knock on the same point twice per second under system operating.	
2	Line Drawing life (no contact CTP)	> 100,000; Use 11mm diameter/copper column to draw straight lines back and forth as the following red lines at the speed of 100mm/sec under system operating.	

12. Appearance Specification

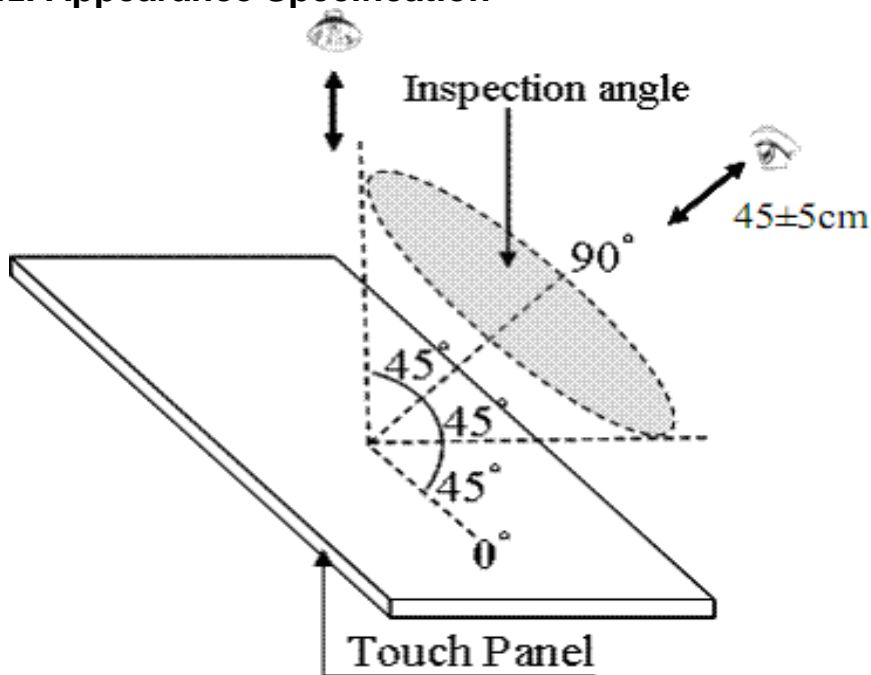

12.1 Environment : $22 \pm 3^{\circ}\text{C}$, Inspection distance : $45 \pm 5\text{cm}$.

12.2 Angle of Visual : $90^{\circ} \pm 5^{\circ}$.

12.3 Light illumination: 800 Lux.

12.4 Inspection top side and bottom side view area duration : 5s

12.5 Inspection four edge ink area duration: 2s

12.6 Specification

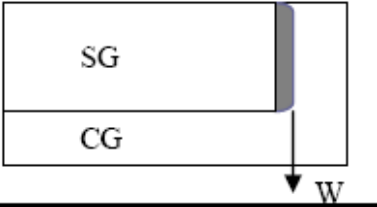
Item	Specification	
Circular Defects	Diameter(mm)	Spec
	$D \leq 0.3\text{mm}$	No quantity limit
	$0.3 < D \leq 0.8 \text{ mm}$	Max 5 defect
	$0.5 \text{ mm} < D$	Reject
	The minimum distance of defects must be above 5mm. The particle will be ignored when it is removable by cleaning.	
Bubble Defects	Diameter(mm)	Spec
	$D \leq 0.2\text{mm}$	No quantity limit
	$0.2 < D \leq 0.3 \text{ mm}$	Max 3 defect
	$0.3 < D \leq 0.5 \text{ mm}$	Max 2 defect
	$0.5 \text{ mm} < D$	Reject
The minimum distance of defects must be above 5mm.		
Linear Object	Width(W)/Length(L)(mm)	Spec
	$W \leq 0.1 \text{ mm} , L \leq 5.0 \text{ mm}$	No quantity limit
	$W \leq 0.1 \text{ mm} , L \leq 10 \text{ mm}$	Max 3 defect
	$W \leq 0.2\text{mm} , L \leq 5.0 \text{ mm}$	Max 3 defect
	The minimum distance of defects must be above 5mm. The liner object will be ignored when it is removable by cleaning.	
Scratch	Width(W)/Length(L)(mm)	Spec
	$W \leq 0.05, L \leq 10.0\text{mm}$	No quantity limit
	$0.05 < W \leq 0.1\text{mm}, L \leq 10.0\text{mm}$	Max 5 defect
	$W < 0.1 \text{ mm} , L < 10.0 \text{ mm}$	Reject
The minimum distance of defects must be above 10mm.		
Pin hole (Ink Area)	Diameter(mm)	Spec
	$D \leq 0.2\text{mm}$	No quantity limit
	$0.2 < D \leq 0.3 \text{ mm}$	Max 5 defect
	$0.3\text{mm} < D$	Reject
The minimum distance of defects must be above 10mm.		
UV Glue extension (Bottom View)	Width(W) (mm)	
	$D \leq 2\text{mm}$	
		
<Remark> D=Diameter W=Width L=Length		

13. QUALITY ASSURANCE

13.1 Test Condition

13.1.1 Temperature and Humidity(Ambient Temperature)

Temperature : $25 \pm 5^{\circ}\text{C}$

Humidity : $65 \pm 5\%$

13.1.2 Operation

Unless specified otherwise, test will be conducted under function state.

13.1.3 Container

Unless specified otherwise, vibration test will be conducted to the product itself without putting it in a container.

13.1.4 Test Frequency

In case of related to deterioration such as shock test. It will be conducted only once.

13.1.5 Test Method

No.	Reliability Test Item & Level	Test Level
1	High Temperature Storage Test	T=80°C, 240hrs, after 4 hrs at room temperature and test.
2	Low Temperature Storage Test	T=-20°C, 240hrs, after 4 hrs at room temperature and test.
3	High Temperature Operation Test	T=70°C, 240hrs, after 4 hrs at room temperature and test.
4	Low Temperature Operation Test	T=-20°C, 240hrs, after 4 hrs at room temperature and test.
5	High Temperature and High Humidity Operation Test	T= 60°C, 80%RH, 240hrs, after 4 hrs at room temperature and test.
6	Temperature Cycle Test (No operation)	-20°C → +25°C → +80°C 30 min 5min 30 min 10 Cycles, after 4 hrs at room temperature and test.
7	Vibration Test (No operation)	Frequency:0 ~ 55 Hz Amplitude:1.5 mm Sweep Time:11min Test Period:6 Cycles for each Direction of X,Y,Z

14. CTP LCM PRODUCT LABEL DEFINE

CTP LCM Product Label style:

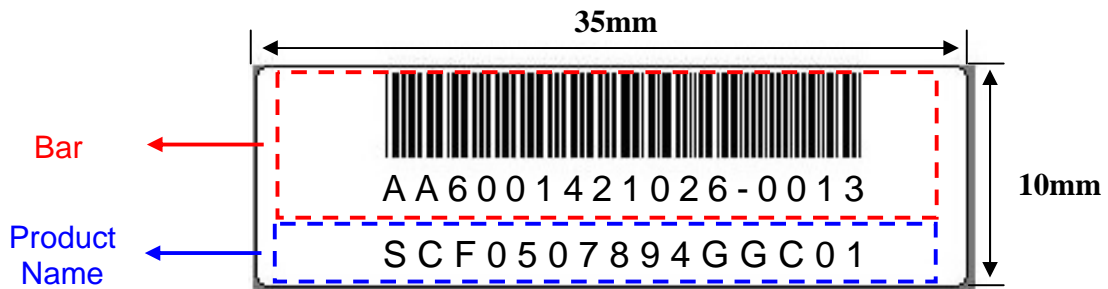

Bar Code Define:

A A 6 0014 2 10 26-0013

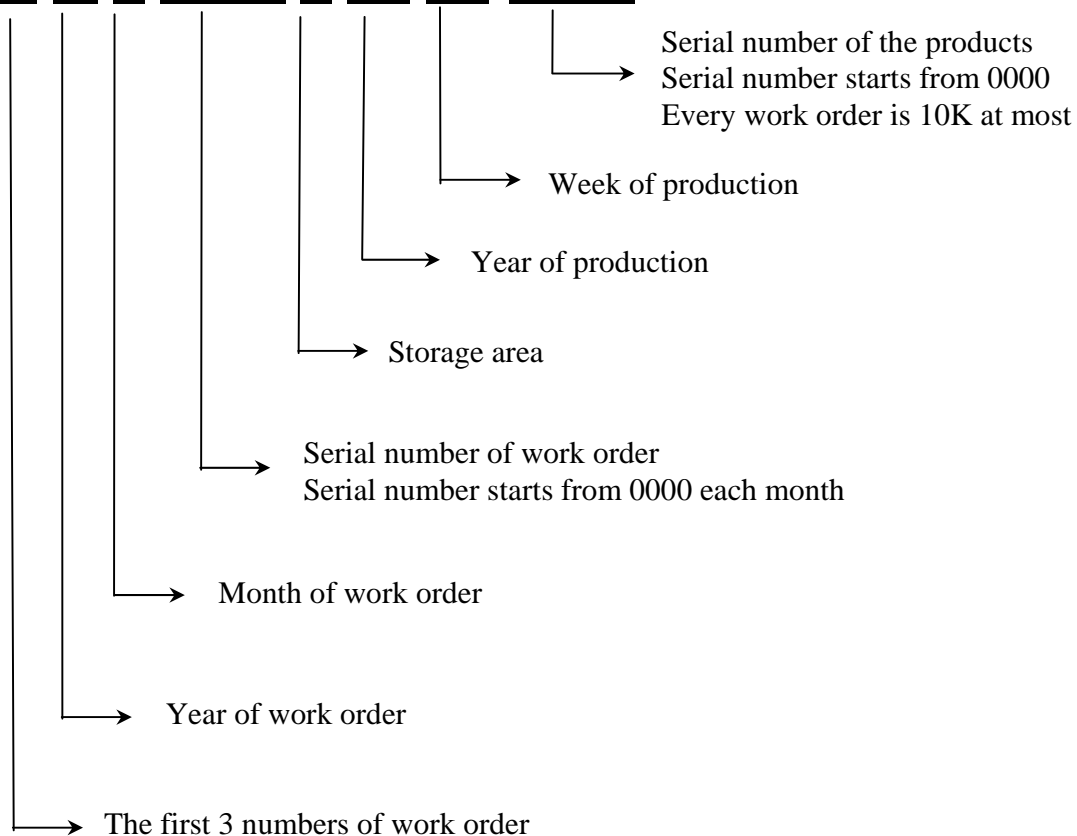

Product Name Define:

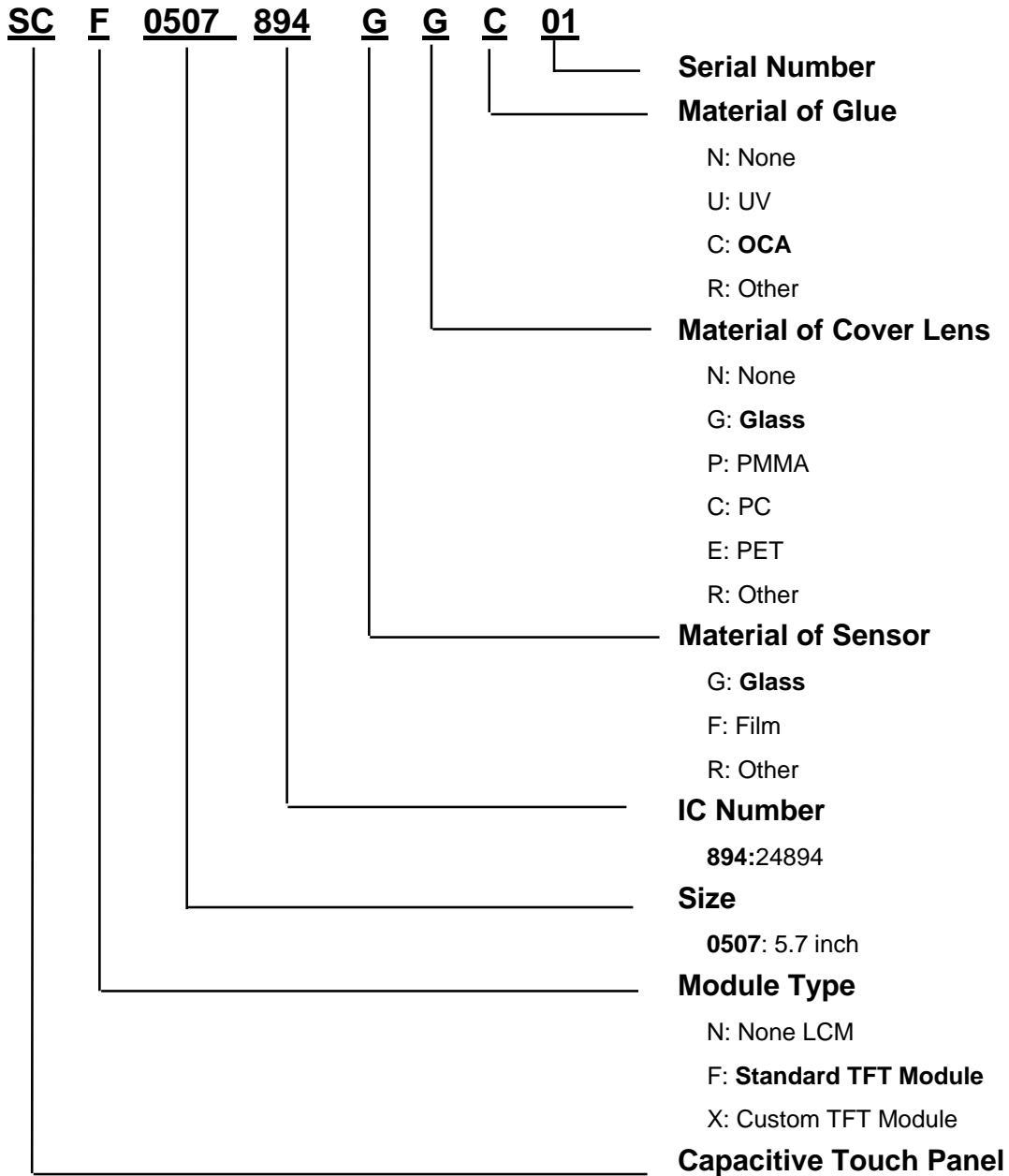

15. PRECAUTIONS IN USE LCM

1. ASSEMBLY PRECAUTIONS

- (1) You must mount a module using holes arranged in four corners or four sides.
- (2) You should consider the mounting structure so that uneven force (ex. Twisted stress) is not applied to the module. And the case on which a module is mounted should have sufficient strength so that external force is not transmitted directly to the module.
- (3) Do not touch, push or rub the exposed polarizers with glass, tweezers or anything harder than HB pencil lead. And please do not rub with dust clothes with chemical treatment.
- (4) Wipe off saliva or water drops as soon as possible. Their long time contact with polarizer causes deformations and color fading.
- (5) Do not open the case because inside circuits do not have sufficient strength.
- (6) Please do not take a LCD module to pieces and reconstruct it. Resolving and reconstructing modules may cause them not to work well.
- (7) Please do not touch metal frames with bare hands and soiled gloves. A color change of the metal frames can happen during a long preservation of soiled LCD modules.
- (8) Please pay attention to handling lead wire of backlight so that it is not tugged in connecting with inverter.

2. OPERATING PRECAUTIONS

- (1) Please be sure to turn off the power supply before connecting and disconnecting signal input cable.
- (2) Please do not change variable resistance settings in LCD module. They are adjusted to the most suitable value. If they are changed, it might happen LCD does not satisfy the characteristics specification
- (3) Be careful for condensation at sudden temperature change. Condensation makes damage to polarizer or electrical contacted parts. And after fading condensation, smear or spot will occur.
- (4) When fixed patterns are displayed for a long time, remnant image is likely to occur.
- (5) Module has high frequency circuits. Sufficient suppression to the electromagnetic interference shall be done by system manufacturers. Grounding and shielding methods may be important to minimize the interference.
- (6) Please consider that LCD backlight takes longer time to become stable of radiation characteristics in low temperature than in room temperature.

3. ELECTROSTATIC DISCHARGE CONTROL

- (1) The operator should be grounded whenever he/she comes into contact with the module. Never touch any of the conductive parts such the copper leads on the PCB and the interface terminals with any

parts of the human body.

- (2) The modules should be kept in antistatic bags or other containers resistant to static for storage.
 - (3) Only properly grounded soldering irons should be used.
 - (4) If an electric screwdriver is used, it should be well grounded and shielded from commutator sparks.
 - (5) The normal static prevention measures should be observed for work clothes and working benches; for the latter conductive (rubber) mat is recommended
 - (6) Since dry air is inductive to statics, a relative humidity of 50-60% is recommended.
- ### 4. STORAGE PRECAUTIONS
- (1) When you store LCDs for a long time, it is recommended to keep the temperature between 0°C-40°C without the exposure of sunlight and to keep the humidity less than 90%RH.
 - (2) Please do not leave the LCDs in the environment of high humidity and high temperature such as 60°C 90%RH
 - (3) Please do not leave the LCDs in the environment of low temperature; below -20°C.
- ### 5. OTHERS
- (1) A strong incident light into LCD panel might cause display characteristics' changing inferior because of polarizer film, color filter, and other materials becoming inferior. Please do not expose LCD module direct sunlight and strong UV rays
 - (2) Please pay attention to a panel side of LCD module not to contact with other materials in preserving it alone.
 - (3) For the packaging box, please pay attention to the followings:
 - a. Please do not pile them up more than 5 boxes. (They are not designed so.) And please do not turn over.
 - b. Please handle packaging box with care not to give them sudden shock and vibrations. And also please do not throw them up.
 - c. Packing box and inner case for LCDs are made of cardboard. So please pay attention not to get them wet. (Such like keeping them in high humidity or wet place can occur getting them wet.)
- ### 6. LIMITED WARRANTY
- Unless otherwise agreed between DATA IMAGE and customer, DATA IMAGE will replace or repair any of its LCD and LCM which is found to be defective electrically and visually when inspected in accordance with DATA IMAGE acceptance standards, for a period on one year from date of shipment. Confirmation of such date shall be based on freight documents. The warranty liability of DATA IMAGE is limited to repair and/or replacement on the terms set forth above. DATA IMAGE will not responsible for any subsequent or consequential events.

Confidential Document
16. OUTLINE DRAWING

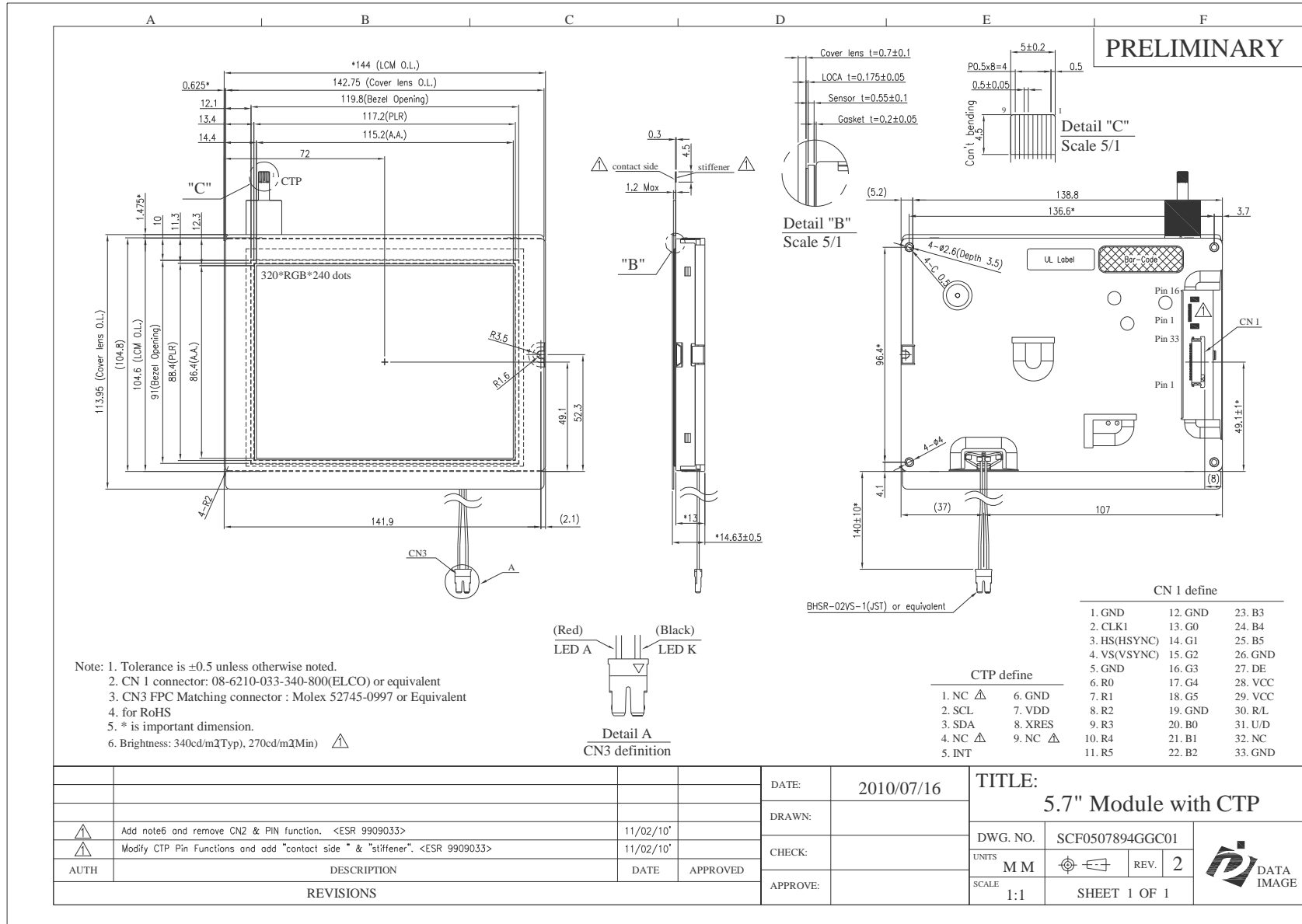

17. PACKAGE INFORMATION

TBD