

TFT-Display Datenblatt

Modell SCF0700894GGU00

Kurzdaten

Hersteller	Data Image
Diagonale	7" / 17,8cm
Format	15:9
Auflösung	800x480
Backlight	LED / 280cd/m ²
Interface	TTL
Touchscreen	ja
Temperatur	«-20...+70»°C (Betrieb)



Confidential Document

DATA IMAGE CORPORATION

TFT Module Specification Preliminary

ITEM NO.: SCF0700894GGU00

Table of Contents

1. COVER & CONTENTS	1
2. RECORD OF REVISION	2
3. APPLICATION.....	3
4. GENERAL SPECIFICATIONS	3
5. ABSOLUTE MAXIMUM RATINGS	3
6. ELECTRICAL CHARACTERISTICS	4
7. TIMING SPECIFICATIONS	5
8. OPTICAL CHARACTERISTIC	11
9. PIN CONNECTIONS	14
10. BLOCK DIAGRAM	16
11. QUALITY ASSURANCE	17
12. APPEARANCE SPECIFICATION.....	18
13. LCM NUMBERING SYSTEM	22
14. PRECAUTIONS IN USE LCM	23
15. OUTLINE DRAWING	24
16. PACKAGE INFORMATION.....	25

Customer Companies	R&D Dept.	Q.C. Dept.	Eng. Dept.	Prod. Dept.
Approved by	Version:	Issued Date:	Sheet Code:	Total Pages:
	1.0	16/August/10		25

3. APPLICATION

DVD player, Car TV, UMPC, POS

4. GENERAL SPECIFICATIONS

Parameter	Specifications	Unit
Screen Size	7 (diagonal)	inch
Display Format	800(H) x (R,G,B) x 480(V)	dot
Active Area	152.4(H) x 91.44(V)	mm
Dot Pitch	0.0635 (H) x 0.1905 (V)	mm
Pixel Configuration	Stripe	
Outline Dimension	174.44(W) x 113.62(H) x 5.03(D)	mm
Surface treatment	Anti-glare	
Back-light	LED	
Display mode	Normally White	
Weight	TBD	g
View Angle direction	Wide View	

5. ABSOLUTE MAXIMUM RATINGS

5.1 LCM Absolute Maximum Rating

Parameter	Symbol	MIN.	MAX.	Unit	Remark
Power supply voltage	VCC	-0.3	7	V	Ta=25°C
Logic input voltage	VI	-0.3	V _{CC} +0.3	V	
Operating temperature	Top	-20	70	°C	Module surface*
Storage temperature	Tst	-30	+80	°C	-
Humidity	Operation	20%~90% relative humidity			Ta<=38°C
	Non Operation	5%~90% relative humidity			Ta<=38°C

5.2 CTP Absolute Maximum Rating

Symbol	Description	Min	Typ	Max	Unit	Notes
Vdd	Supply voltage	-0.5	-	6.0	V	
Vio	DC input voltage	GND-0.5	-	Vdd+0.5	V	
Imio	Maximum input current	-25	-	+50	mA	
ESD	Electrostatic discharge voltage	2000	-	-	V	

6. ELECTRICAL CHARACTERISTICS

6.1 LCM Electrical Characteristic

GND=0V, f_H=31.5KHz, f_V=60Hz, f_{CLK}=33.26MHz, T_a=25°C

Parameter	Symbol	MIN.	Typ.	MAX.	Unit	Remark
Power Supply voltage for LCD	V _{CC}	3.0	3.3	3.6	V	
Power Supply Current for LCD	I _{CC}		150	200	mA	V _{CC} =3.3V
Ripple voltage	V _{RF}	-	-	100	mV _{P-P}	
"H" level logical input voltage	V _{IH}	0.7V _{CC}	--	V _{CC}	V	
"L" level logical input voltage	V _{IL}	0	--	0.3V _{CC}	V	

6.2 Backlight Driving Consumption

T_a= 25 °C

Parameter	Symbol	Min.	Typ.	Max.	Unit	Remark
VLED voltage	V _L	8.4	--	10.8	V	Note1
LED current	I _L	-	180	-	mA	
LED dice life time		20,000	30,000		hr	Note2

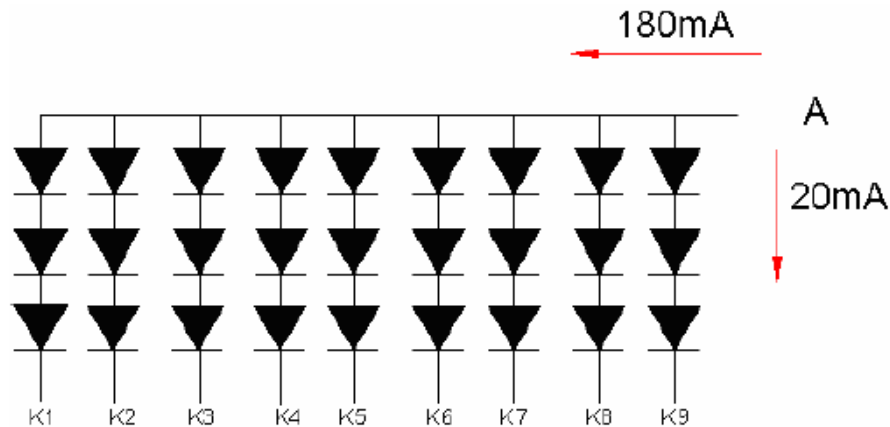

Note1: There are 9 Groups (1 Group of three LEDs).

VLED 1,2,3,4,5,6,7,8,9,=8.4V(min)

Note2: The "LED dice life time" is defined as the brightness decrease to 50% original brightness that the ambient temperature is 18°C~28°C and LED dice current=20mA.

6.3 CTP Electrical Characteristic

Symbol	Description	Min	Typ	Max	Unit	Notes
V _{dd}	Supply voltage	4.75	5	5.25	V	
I	Supply current	-	-	24	mA	At V _{dd} =5V
I _{sleep}	Sleep mode current	-	-	900	uA	At V _{dd} =5V

7. TIMING SPECIFICATIONS

7.1 LCM AC Characteristics

7.1.1 AC Electrical Characteristics

ITEM	SYMBOL	MIN.	TYP.	MAX.	UNIT
HS setup time	T_{hst}	6	-	-	ns
HS hold time	T_{hhd}	6	-	-	ns
VS setup time	T_{vst}	6	-	-	ns
VS hold time	T_{vhd}	6	-	-	ns
Data setup time	T_{dsu}	6	-	-	ns
Data hold time	T_{dhd}	6	-	-	ns
DE setup time	T_{esu}	6	-	-	ns

7.1.2 Resolution : 800x480

- sync mode

ITEM	SYMBOL	MIN.	TYP.	MAX.	UNIT
CLK frequency	F_{CPH}	-	33.26	-	MHz
CLK period	T_{CPH}	-	30.06	-	ns
CLK pulse duty	T_{CWH}	40	50	60	%
HS period	T_H	-	1056	-	T_{CPH}
HS pulse width	T_{WH}	1	128	-	T_{CPH}
HS-first horizontal data time	T_{HS}	-	216	-	T_{CPH}
HS Active Time	T_{HA}	-	800	-	T_{CPH}
VS period	T_V	-	525	-	T_H
VS pulse width	T_{WV}	1	2	-	T_H
VS-DE time	T_{VS}	-	35	-	T_H
VS Active Time	T_{VA}	-	480	-	T_H

- DE mode

ITEM	SYMBOL	MIN.	TYP.	MAX.	UNIT
CLK frequency	F_{CPH}	-	33.26	-	MHz
CLK period	T_{CPH}	-	30.06	-	ns
CLK pulse duty	T_{CWH}	40	50	60	%
DE period	$T_{DEH}+T_{DEL}$	1000	1056	1200	T_{CPH}
DE pulse width	T_{DH}	-	800	-	T_{CPH}
DE frame blanking	T_{HS}	10	45	110	$T_{DEH}+T_{DEL}$
DE frame width	T_{EP}	-	480	-	$T_{DEH}+T_{DEL}$

ITEM	SYMBOL	MIN.	TYP.	MAX.	UNIT
OEV pulse width	T_{OEV}	-	150	-	T_{CPH}
CKV pulse width	T_{CKV}	-	133	-	T_{CPH}
DE(internal)-STV time	T_1	-	4	-	T_{CPH}
DE(internal)-CKV time	T_2	-	40	-	T_{CPH}
DE(internal)-OEV time	T_3	-	23	-	T_{CPH}
DE(internal)-POL time	T_4	-	157	-	T_{CPH}
STV pulse width	-	-	1	-	T_H

7.2 LCM Timing Controller Timing Chart

7.2.1 Clock and Data input waveforms

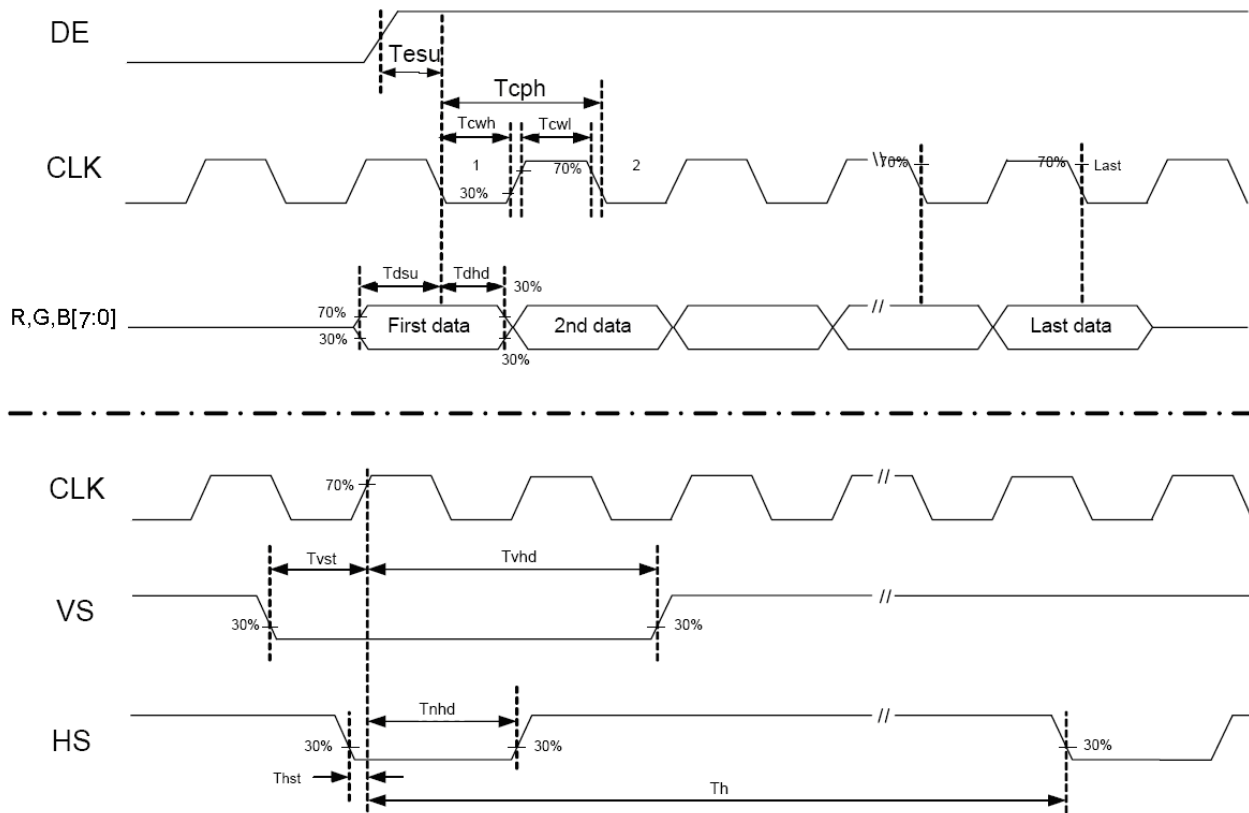

Figure 1 Clock and Data input waveforms.

7.2.2 Data Input format

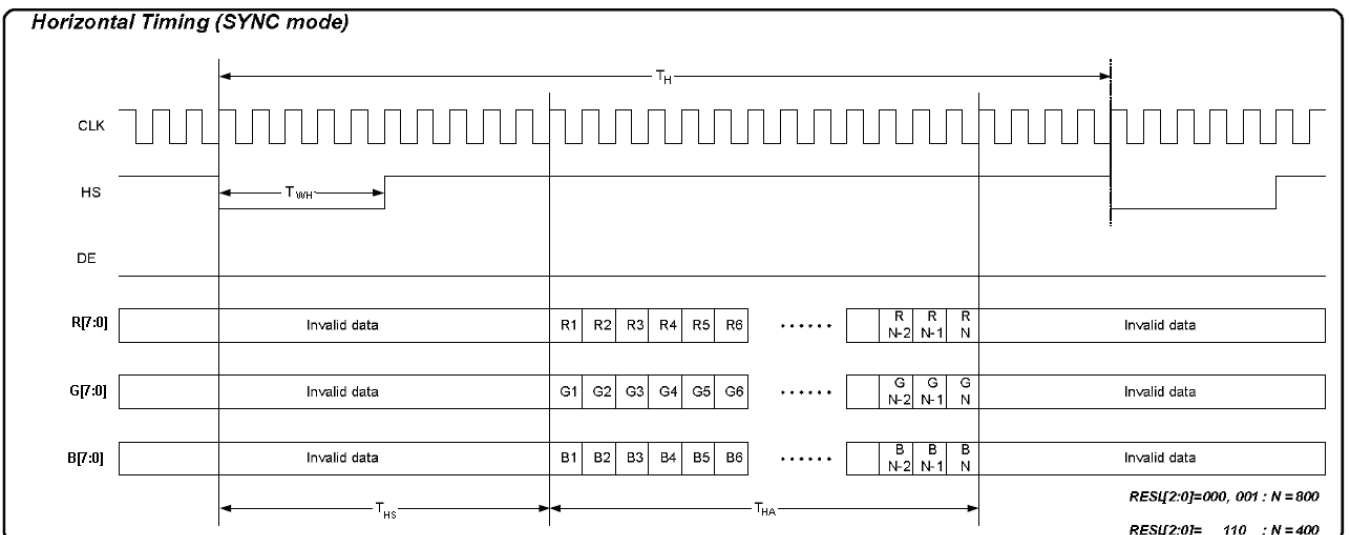
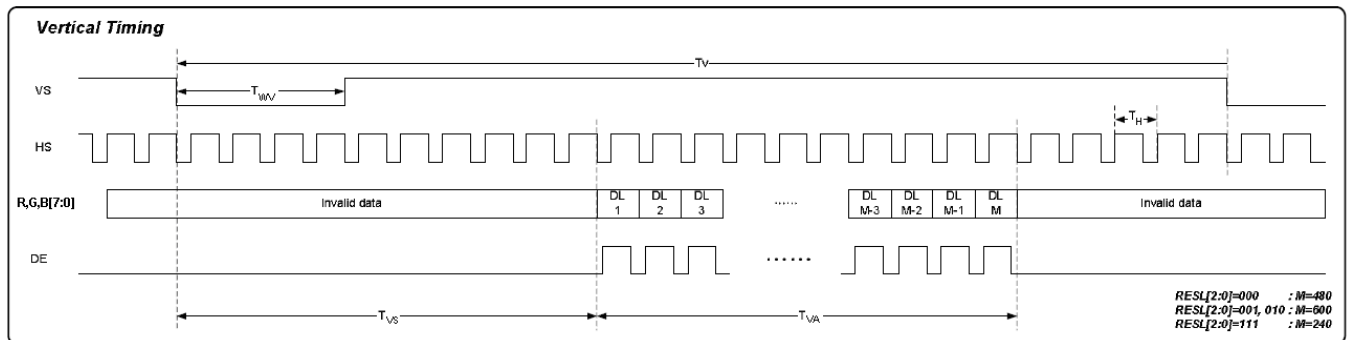
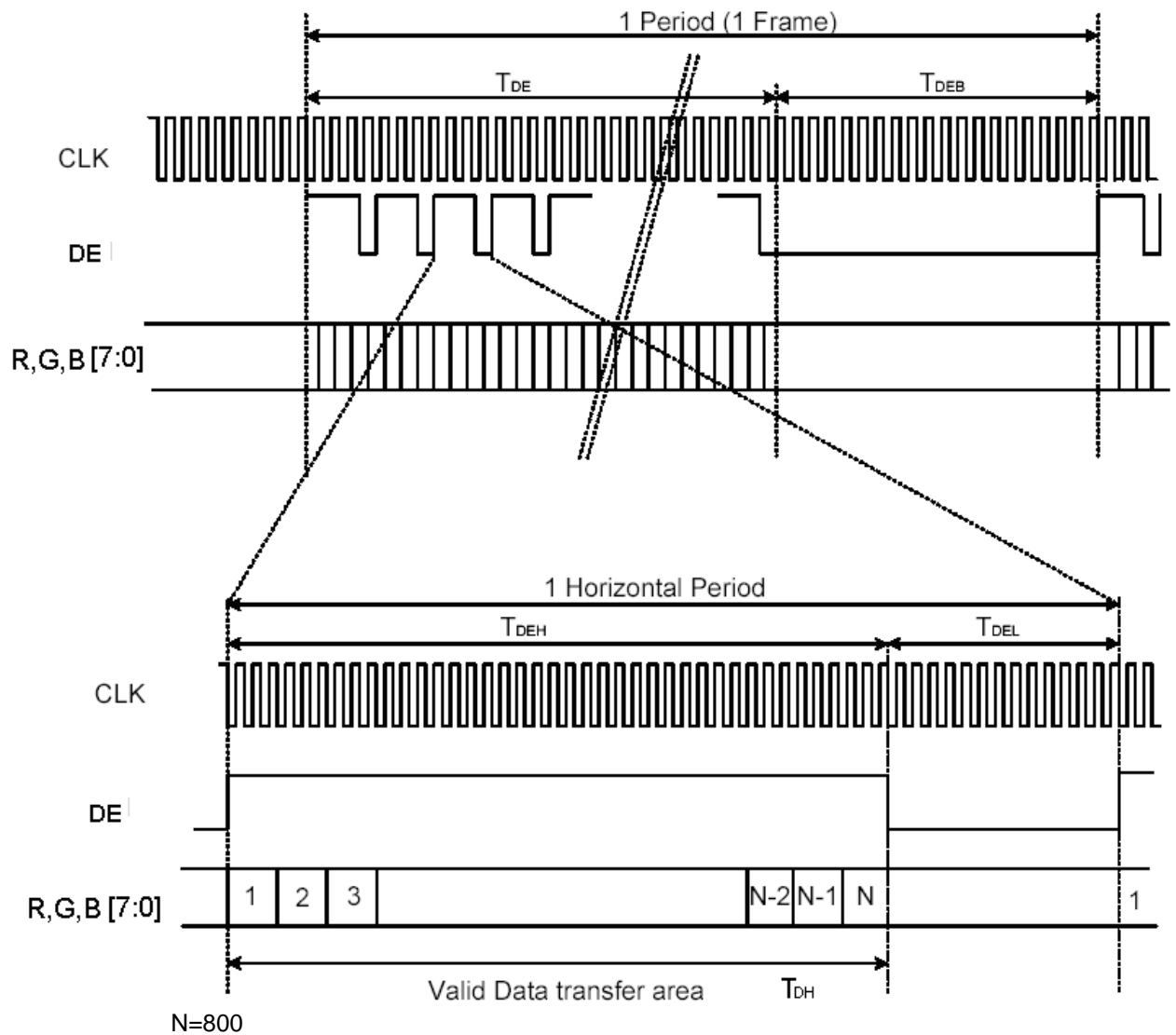

Figure 2 SYNC Mode Horizontal Data Format

Figure 3 SYNC Mode Vertical Data Format
7.2.3 DE Mode Data Format

Figure 4 DE Mode Data Format

7.3 LCM Color Data Input Assignment

COLOR	DISPLAY	DATA SIGNAL																				GRAY SCALE LEVEL				
		RED							GREEN							BLUE										
		R0	R1	R2	R3	R4	R5	R6	R7	G0	G1	G2	G3	G4	G5	G6	G7	B0	B1	B2	B3		B4	B5	B6	B7
BASIC COLOR	BLACK	0	0	0	0	0	0	0	0	0	0	0	0	0	0	0	0	0	0	0	0	0	0	0	-	
	BLUE	0	0	0	0	0	0	0	0	0	0	0	0	0	0	0	0	1	1	1	1	1	1	1	1	-
	GREEN	0	0	0	0	0	0	0	0	1	1	1	1	1	1	1	1	0	0	0	0	0	0	0	0	-
	CYAN	0	0	0	0	0	0	0	0	1	1	1	1	1	1	1	1	1	1	1	1	1	1	1	1	-
	RED	1	1	1	1	1	1	1	1	0	0	0	0	0	0	0	0	0	0	0	0	0	0	0	0	-
	MAGENTA	1	1	1	1	1	1	1	1	0	0	0	0	0	0	0	0	1	1	1	1	1	1	1	1	-
	YELLOW	1	1	1	1	1	1	1	1	1	1	1	1	1	1	1	1	0	0	0	0	0	0	0	0	-
	WHITE	1	1	1	1	1	1	1	1	1	1	1	1	1	1	1	1	1	1	1	1	1	1	1	1	-
GRAY SCALE OF RED	BLACK	0	0	0	0	0	0	0	0	0	0	0	0	0	0	0	0	0	0	0	0	0	0	0	R0	
	DARK ↑	1	0	0	0	0	0	0	0	0	0	0	0	0	0	0	0	0	0	0	0	0	0	0	R1	
		0	1	0	0	0	0	0	0	0	0	0	0	0	0	0	0	0	0	0	0	0	0	0	R2	
		:	:	:	:	:	:	:	:	:	:	:	:	:	:	:	:	:	:	:	:	:	:	:	:	R3-R252
		:	:	:	:	:	:	:	:	:	:	:	:	:	:	:	:	:	:	:	:	:	:	:	:	
		1	0	1	1	1	1	1	1	1	0	0	0	0	0	0	0	0	0	0	0	0	0	0	0	R253
	0	1	1	1	1	1	1	1	1	0	0	0	0	0	0	0	0	0	0	0	0	0	0	0	R254	
RED	1	1	1	1	1	1	1	1	0	0	0	0	0	0	0	0	0	0	0	0	0	0	0	R255		
GRAY SCALE OF GREEN	BLACK	0	0	0	0	0	0	0	0	0	0	0	0	0	0	0	0	0	0	0	0	0	0	0	G0	
	DARK ↑	0	0	0	0	0	0	0	0	1	0	0	0	0	0	0	0	0	0	0	0	0	0	0	G1	
		0	0	0	0	0	0	0	0	0	1	0	0	0	0	0	0	0	0	0	0	0	0	0	G2	
		:	:	:	:	:	:	:	:	:	:	:	:	:	:	:	:	:	:	:	:	:	:	:	G3-G252	
		:	:	:	:	:	:	:	:	:	:	:	:	:	:	:	:	:	:	:	:	:	:	:		
		0	0	0	0	0	0	0	0	0	1	0	1	1	1	1	1	1	0	0	0	0	0	0	0	G253
	0	0	0	0	0	0	0	0	0	1	1	1	1	1	1	1	1	0	0	0	0	0	0	0	G254	
GREEN	0	0	0	0	0	0	0	0	1	1	1	1	1	1	1	1	0	0	0	0	0	0	0	G255		
GRAY SCALE OF BLUE	BLACK	0	0	0	0	0	0	0	0	0	0	0	0	0	0	0	0	0	0	0	0	0	0	0	B0	
	DARK ↑	0	0	0	0	0	0	0	0	0	0	0	0	0	0	0	0	1	0	0	0	0	0	0	B1	
		0	0	0	0	0	0	0	0	0	0	0	0	0	0	0	0	0	1	0	0	0	0	0	B2	
		:	:	:	:	:	:	:	:	:	:	:	:	:	:	:	:	:	:	:	:	:	:	:	B3-B252	
		:	:	:	:	:	:	:	:	:	:	:	:	:	:	:	:	:	:	:	:	:	:	:		
		0	0	0	0	0	0	0	0	0	0	0	0	0	0	0	0	0	1	0	1	1	1	1	1	B253
	0	0	0	0	0	0	0	0	0	0	0	0	0	0	0	0	0	1	1	1	1	1	1	1	B254	
BLUE	0	0	0	0	0	0	0	0	0	0	0	0	0	0	0	0	1	1	1	1	1	1	1	B255		

Note) Definition of Gray :

Rn : Red Gray, Gn : Green Gray, Bn : Blue Gray (n = Gray level)

Input Signal : 0 = Low level voltage, 1 = High level voltage

7.4 CTP Data Format

7.4.1 I2C data Format

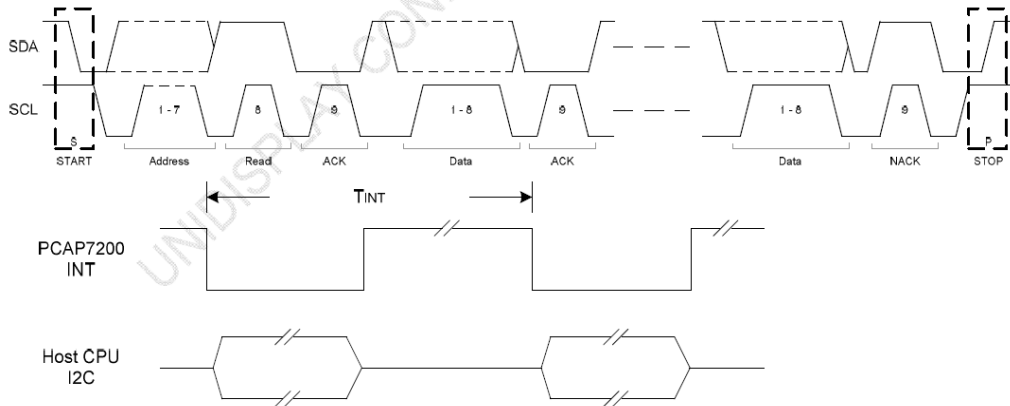

Report rate = $1 / T_{INT}$, it depends on properties of touch screen such as resistive value, channel number, thickness and material of cover lens, etc.

7.4.2 Read mode: Master-receiver, slave-transmitter.

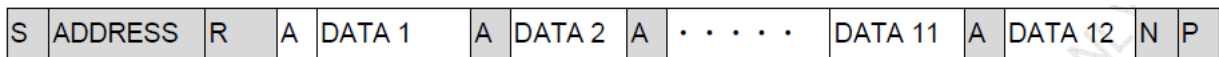

7.4.3 Write mode: Master-transmitter, slave-receiver.

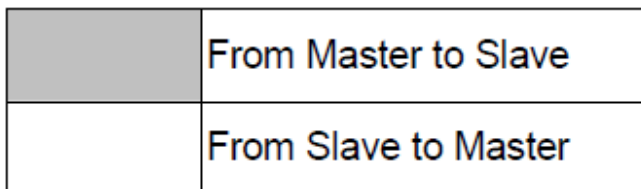
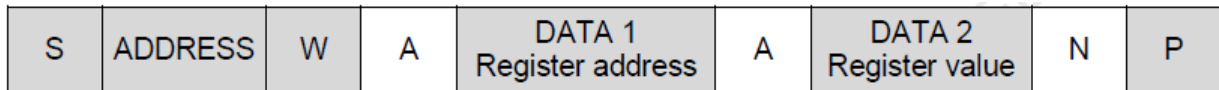

S = START condition

P = STOP condition

R = Data direction READ (SDA HIGH)

W = Data direction WRITE (SDA LOW)

A = Acknowledge (SDA LOW)

N = Not acknowledge (SDA HIGH)

ADDRESS = 7-bit (0Ah)

DATA = 8-bit

7.4.4 Timing characteristics for I2C SDA & SCL

Symbol	Description	Standard Mode		Fast Mode		Units	Notes
		Min	Max	Min	Max		
$F_{SCL I2C}$	SCL Clock Frequency	0	100	0	400	kHz	
$T_{HDSTA I2C}$	Hold Time (repeated) START Condition. After this period, the first clock pulse is generated.	4.0	–	0.6	–	μ s	
$T_{LOW I2C}$	LOW Period of the SCL Clock	4.7	–	1.3	–	μ s	
$T_{HIGH I2C}$	HIGH Period of the SCL Clock	4.0	–	0.6	–	μ s	
$T_{SUSTA I2C}$	Set-up Time for a Repeated START Condition	4.7	–	0.6	–	μ s	
$T_{HDDAT I2C}$	Data Hold Time	0	–	0	–	μ s	
$T_{SUDAT I2C}$	Data Set-up Time	250	–	100 ^[16]	–	ns	
$T_{SUSTO I2C}$	Set-up Time for STOP Condition	4.0	–	0.6	–	μ s	
$T_{BUF I2C}$	Bus Free Time Between a STOP and START Condition	4.7	–	1.3	–	μ s	
T_{SPI2C}	Pulse Width of spikes are suppressed by the input filter.	–	–	0	50	ns	

AC Characteristics of the I2C SDA and SCL Pins for Vdd

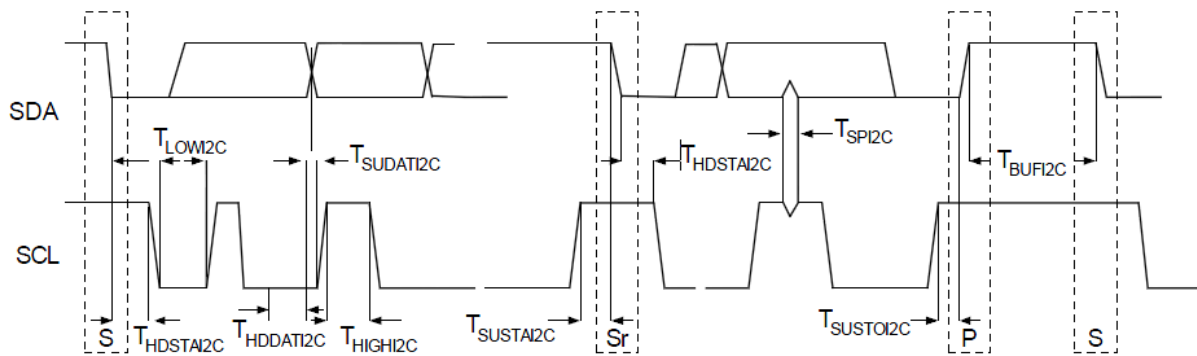

Definition for Timing for Fast/Standard Mode on the I2C Bus

Note16:

A Fast-Mode I2C-bus device can be used in a Standard-Mode I2C-bus system, but the requirement $t_{SU;DAT} \geq 250$ ns must then be met. This automatically is the case if the device does not stretch the LOW period of the SCL signal. If such device does stretch the LOW period of the SCL signal, it must output the next data bit to the SDA line $t_{max} + t_{SU;DAT} = 1000 + 250 = 1250$ ns (according to the Standard-Mode I2C-bus specification) before the SCL line is released.

8. OPTICAL CHARACTERISTIC

8.1 LCM OPTICAL CHARACTERISTIC

Parameter	Symbol	Condition	MIN.	TYP.	MAX.	Unit	Remarks
Viewing Angle	Horizontal	θ_{x+}	60	70	--	deg	Note 1,4
		θ_{x-}	60	70	--		
	Vertical	θ_{y+}	40	50	--		
		θ_{y-}	50	60	--		
Contrast Ratio	CR	at optimized viewing angle	300	400	--		Note 1,3
Response time	Rise	Tr	-	5	10	ms	Note 1,6
	Fall	Tf	-	15	20	ms	
Uniformity	B-uni	$\theta_x=\theta_y=0^\circ$	70	80	--	%	Note1,5
Brightness	L	$\theta_x=\theta_y=0^\circ$	220	280	--	cd/m ²	Note 1,2
Chromaticity	x_W	Center $\theta_x=\theta_y=0^\circ$	0.269	0.309	0.349		Note 1,7
	y_W		0.299	0.339	0.379		
	x_R		0.562	0.602	0.642		
	y_R		0.314	0.354	0.394		
	x_G		0.278	0.318	0.358		
	y_G		0.496	0.536	0.576		
	x_B		0.104	0.144	0.184		
	y_B		0.089	0.129	0.169		
Image sticking	tis	2 hours			2	Sec	Note 8

The following optical specifications shall be measured in a darkroom or equivalent state (ambient luminance ≤ 1 lux, and at room temperature).

The operation temperature is $25^\circ\text{C} \pm 2^\circ\text{C}$ and LED Backlight Current $I_L=180\text{mA}$.

The measurement method is shown in Note1.

Note1: The method of optical measurement:

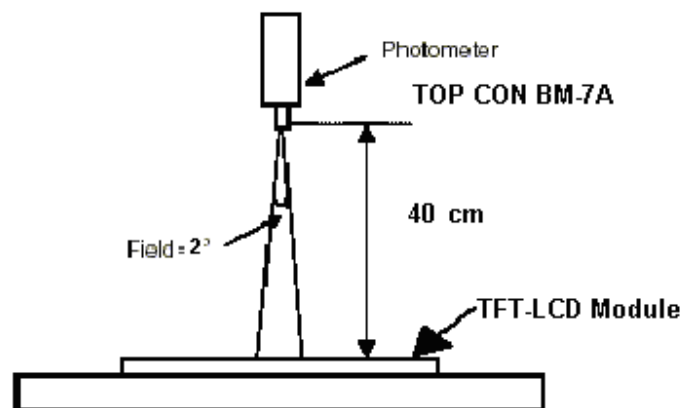

Note2: Measured at the center area of the panel and at the viewing angle of the $\theta_x = \theta_y = 0^\circ$

Note3: Definition of Contrast Ratio (CR):

$$CR = \frac{\text{Luminance with all pixels in white state}}{\text{Luminance with all pixels in Black state}}$$

Note4: Definition of Viewing Angle

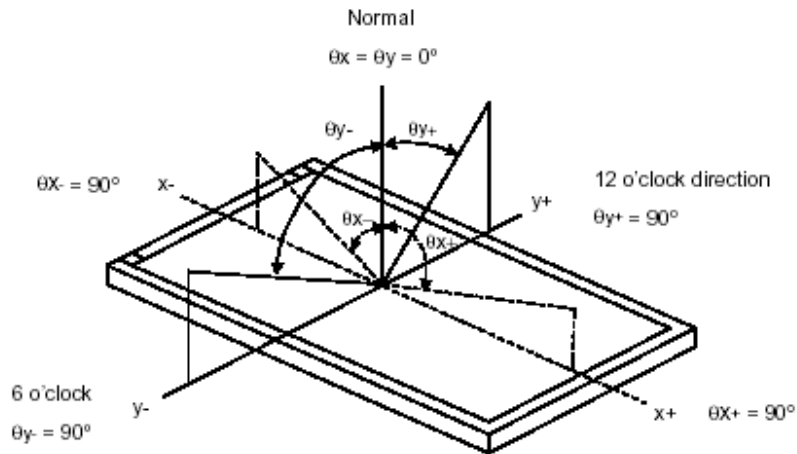

Note 5: Definition of Brightness Uniformity (B-uni):

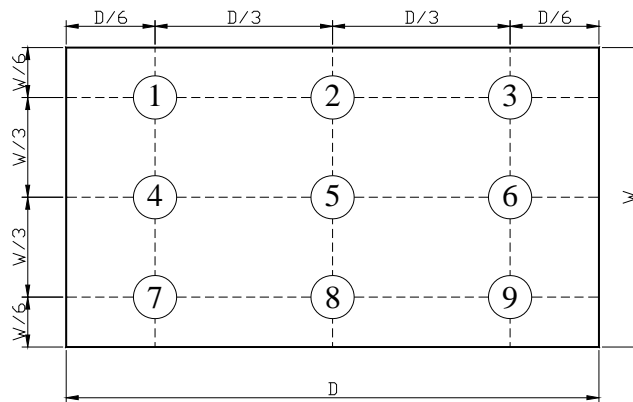

$$B\text{-uni} = \frac{\text{Minimum luminance of 9 points}}{\text{Maximum luminance of 9 points}} \quad (\text{Note 5}).$$

Note6: Definition of Response Time:

The Response Time is set initially by defining the "Rising Time (T_r)" and the "Falling Time (T_f)" respectively. T_r and T_f are defined as following figure.

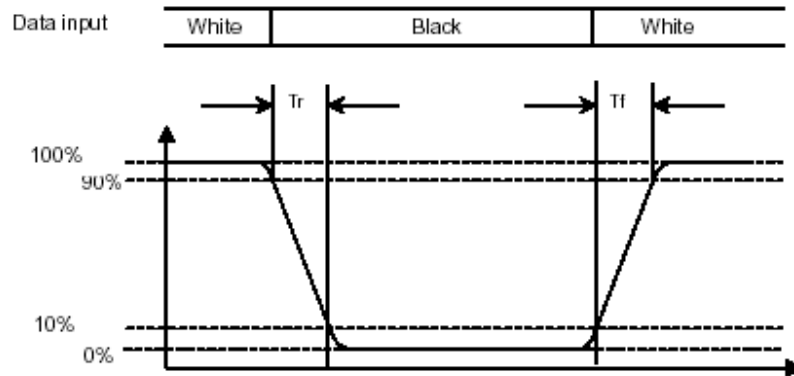

Note 7: Definition of Chromaticity:

The color coordinates (x_w, y_w) , (x_r, y_r) , (x_g, y_g) , and (x_b, y_b) are obtained with all pixels in the viewing field at white, red, green, and blue states, respectively.

Note 8: Definition of Image sticking (tis):

Continuously display the test pattern shown in the figure below for 2 hours. Then display a completely white screen. The previous image shall not persist more than 2 sec at 25 °C

Image sticking pattern

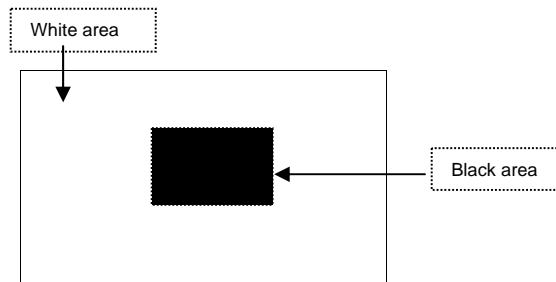

8.2 CTP OPTICAL CHARACTERISTIC

Item	Specifications
Transparency	$\geq 85\%$
Haze	$\leq 1.0\%$

Note : After stabilizing the panel, the measurement should be executed. Measurement should be executed in a stable, windless, and dark room. Optical specifications are measured by CARRY 300

9. PIN CONNECTIONS

9.1 LCM Pin Connections

Pin NO.	SYMBOL	DESCRIPTION
1	GND	Power Ground
2	GND	Power Ground
3	VCC	Power Supply for Digital Circuit
4	VCC	Power Supply for Digital Circuit
5	R0	Red Data 0 (LSB)
6	R1	Red Data 1
7	R2	Red Data 2
8	R3	Red Data 3
9	R4	Red Data 4
10	R5	Red Data 5
11	R6	Red Data 6
12	R7	Red Data 7 (MSB)
13	G0	Green Data 0 (LSB)
14	G1	Green Data 1
15	G2	Green Data 2
16	G3	Green Data 3
17	G4	Green Data 4
18	G5	Green Data 5
19	G6	Green Data 6
20	G7	Green Data 7 (MSB)
21	B0	Blue Data 0 (LSB)
22	B1	Blue Data 1
23	B2	Blue Data 2
24	B3	Blue Data 3
25	B4	Blue Data 4
26	B5	Blue Data 5
27	B6	Blue Data 6
28	B7	Blue Data 7 (MSB)
29	GND	Power Ground
30	CLK	Clock Signals ; Latch Data at the Falling Edge
31	NC	No connection
32	HS	Horizontal Synchronous Signal
33	VS	Vertical Synchronous Signal
34	DE	Data Enable Signal
35	NC	No connection
36	NC	No connection
37	GND	Power Ground
38	GND	Power Ground
39	NC	No connection
40	NC	No connection

Note:

The LCM support both DE mode and Sync mode timing. When DE is pulled low, which is sync mode. When DE is an active data and pulled low for blanking data, which is DE mode.

Remarks:

Power Signal sequence:

- $t1 \leq 10\text{ms}$; $1 \text{ sec} \leq t5$
- $50\text{ms} \leq t2$;
- $0 < t3 \leq 50\text{ms}$;
- $0 < t4 \leq 10\text{ms}$

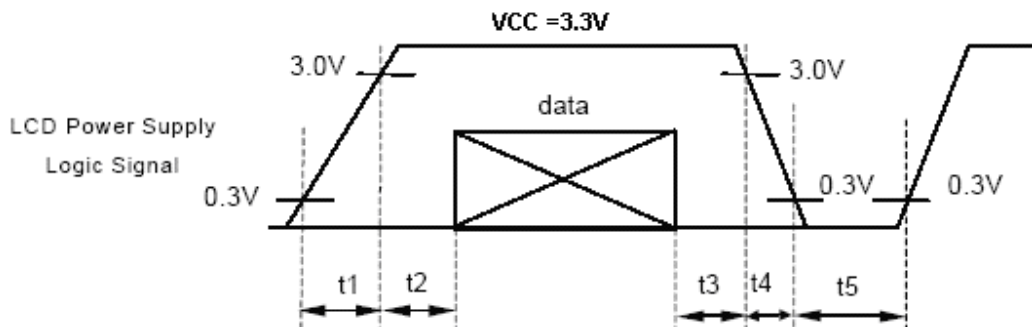

VCC -dip condition:

- (1) $2.7\text{V} \leq VCC \leq 3.0\text{V}$: $t_d \leq 10 \text{ ms}$
- (2) $VCC > 3.0\text{V}$: VCC -dip condition should be the same with VCC,-turn-on condition.

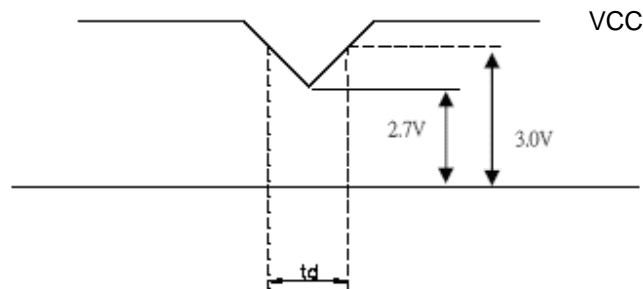

9.2 CTP Pin Connections

Pin Number	Pin Name	Description
1	USB D+	USB D+
2	XRES	Reset active high
3	VDD	Power Supply Voltage
4	GND	Ground
5	INT	Interrupt active low
6	N.C.	No connection.
7	SDA	I2C Data
8	SCL	I2C Clock
9	USB D-	USB D-

10. BLOCK DIAGRAM

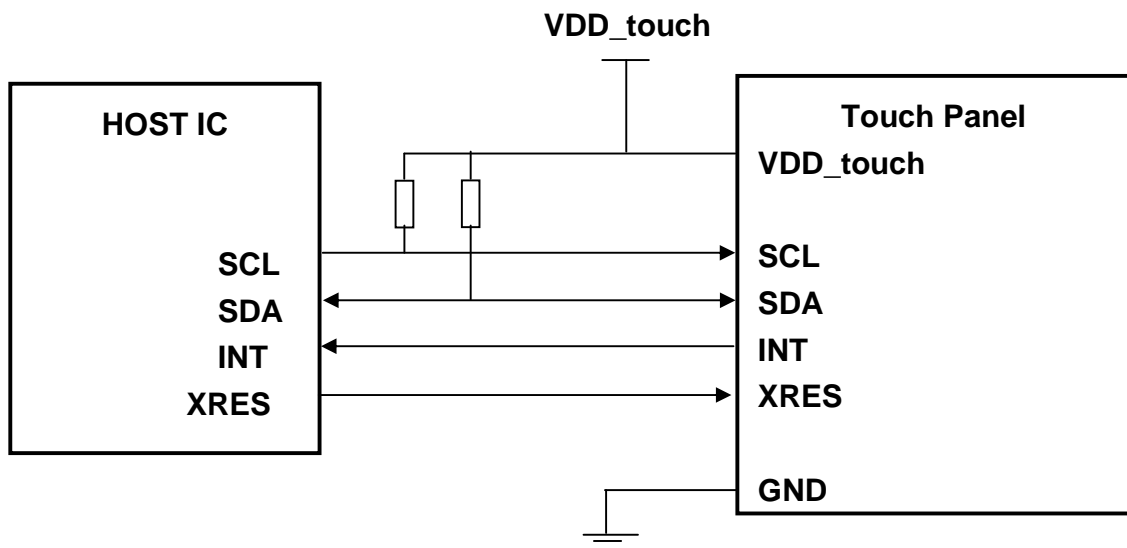
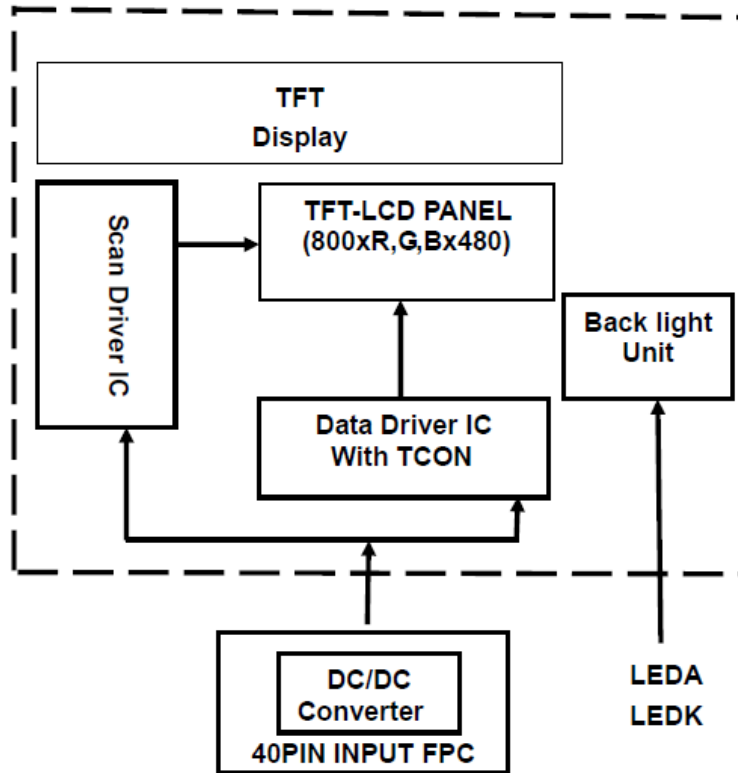

NOTE : 1. USE APPROPRIATE RESISTOR VALUE DURING HIGH SPEED SCL CLOCK.

SUGGESTION : RESISTOR RECOMMENDATION : 1K ohm.

2. To reduce the noise from the power, we suggest you use the independent power for the touch panel (VDD_touch)

11. QUALITY ASSURANCE

11.1 Test Condition

11.1.1 Temperature and Humidity(Ambient Temperature)

Temperature : $25 \pm 5^{\circ}\text{C}$

Humidity : $65 \pm 5\%$

11.1.2 Operation

Unless specified otherwise, test will be conducted under function state.

11.1.3 Container

Unless specified otherwise, vibration test will be conducted to the product itself without putting it in a container.

11.1.4 Test Frequency

In case of related to deterioration such as shock test. It will be conducted only once.

11.1.5 Test Method

Reliability Test Item & Level		Test Level
No.	Test Item	
1.	High Temperature Storage Test	T= 70°C ,120hrs after 1 hrs at room temperature and test.
2.	Low Temperature Storage Test	T= -30°C ,120hrs after 1 hrs at room temperature and test.
3.	High Temperature Operation Test	T= 60°C , 120hrs after 1 hrs at room temperature and test.
4.	Low Temperature Operation Test	T= -20°C , 120hrs after 1 hrs at room temperature and test.
5.	High Temperature and High Humidity Operation Test	T= 40°C ,80%RH,120hrs after 24 hrs at room temperature and test.
6.	Thermal Cycling Test (No operation)	-20°C 30min ~ 60°C 30 min , 10 Cycles after 24 hrs at room temperature and test.
7.	Surface Hardness	Pencil Hardness 7H
8.	Vibration Test (No operation)	Frequency :10 ~ 55 Hz Amplitude :1.5 mm Sweep time : 11 mins Test Period: 6 Cycles for each direction of X, Y, Z
9.	ESD TEST	Air Discharge : ± 15 KV charge & discharge Contact Discharge : ± 2 KV charge & discharge

12. Appearance Specification

12.1 Inspection and Environment conditions

12.1.1 Temperature: $25 \pm 5^\circ\text{C}$

12.1.2 Humidity: $55 \pm 10\% \text{ RH}$

12.1.3 Light source: Fluorescent Light

12.1.4 Inspection: Viewing distance: $35 \pm 5\text{cm}$

12.1.5 Ambient Illumination:

(1) Cosmetic Inspection: 500 ~ 800 lux

(2) Functional Inspection: 400 ~ 600 lux

12.1.6 Inspection View angle:

(1) Inspection under operating condition : $\pm 5^\circ$

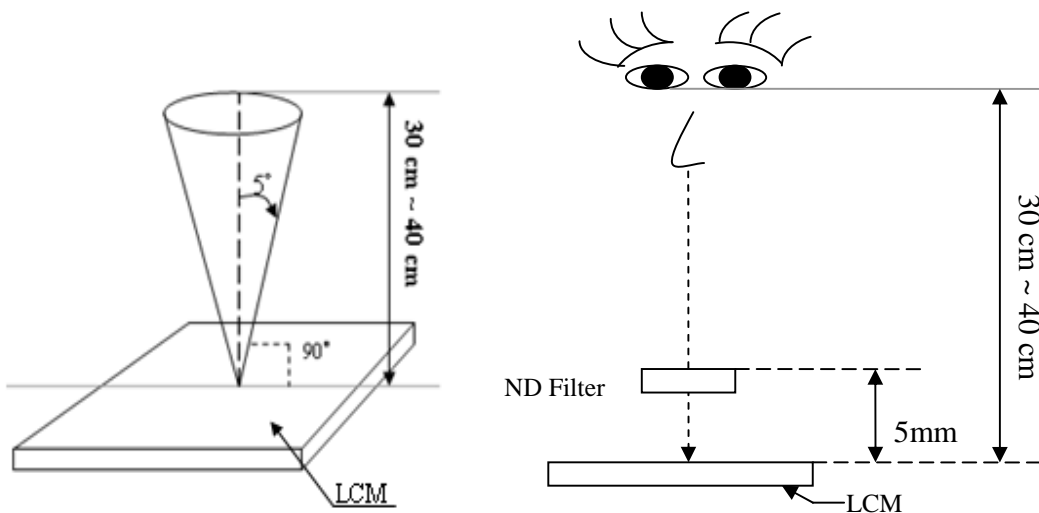

(2) Inspection under non-operating condition : $\pm 45^\circ$



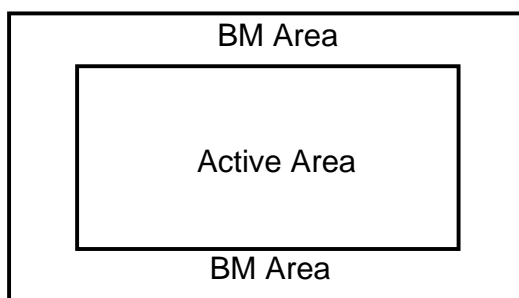

12.2 Definition of applicable Zones

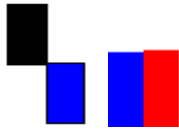
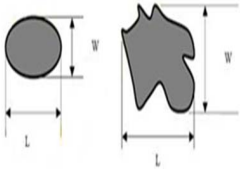
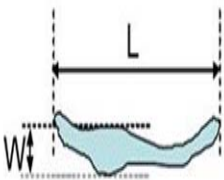

12.3 Cosmetic Specification and Inspection Items

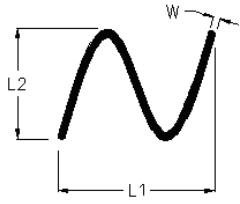
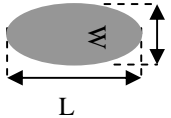
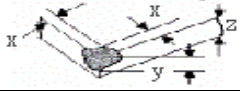
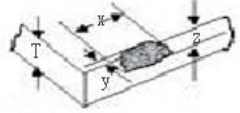
Inspection Item	Inspection Criteria	Illustration												
Display function	No Display malfunction													
Contrast ratio	Does not meet specified range in the spec.	(Major) (Note:2)												
Line Defect	No obvious Vertical and Horizontal line defect in black and White.													
Point Defect	<table border="1"> <thead> <tr> <th rowspan="2">Item</th> <th>Acceptable number</th> <th rowspan="2">Total</th> </tr> <tr> <th>Active Area</th> </tr> </thead> <tbody> <tr> <td>Bright</td> <td>2</td> <td rowspan="2">5</td> </tr> <tr> <td>Dark</td> <td>4</td> </tr> <tr> <td>Two adjacent dot</td> <td>2</td> <td>2</td> </tr> </tbody> </table>	Item	Acceptable number	Total	Active Area	Bright	2	5	Dark	4	Two adjacent dot	2	2	<p>One Dot</p>  <p>Two adjacent dot</p> 
Item	Acceptable number		Total											
	Active Area													
Bright	2	5												
Dark	4													
Two adjacent dot	2	2												
Foreign material (Black or White spots shape)	<table border="1"> <thead> <tr> <th>Zone Dimension</th> <th>Acceptable number</th> <th>Class of Defects</th> </tr> </thead> <tbody> <tr> <td>$D > 0.8 \text{ mm}$</td> <td>0</td> <td rowspan="3">Minor</td> </tr> <tr> <td>$0.3\text{mm} \leq D \leq 0.8 \text{ mm}$</td> <td>5</td> </tr> <tr> <td>$D < 0.3\text{mm}$</td> <td>*</td> </tr> </tbody> </table>	Zone Dimension	Acceptable number	Class of Defects	$D > 0.8 \text{ mm}$	0	Minor	$0.3\text{mm} \leq D \leq 0.8 \text{ mm}$	5	$D < 0.3\text{mm}$	*	 <p>$D = (L + W) / 2$</p>		
Zone Dimension	Acceptable number	Class of Defects												
$D > 0.8 \text{ mm}$	0	Minor												
$0.3\text{mm} \leq D \leq 0.8 \text{ mm}$	5													
$D < 0.3\text{mm}$	*													
Foreign Material (Line shape)	<table border="1"> <thead> <tr> <th>Zone Dimension</th> <th>Acceptable number</th> <th>Class of Defects</th> </tr> </thead> <tbody> <tr> <td>$W > 0.1\text{mm}$ or $L > 10\text{mm}$</td> <td>0</td> <td rowspan="3">Minor</td> </tr> <tr> <td>$0.05 \text{ mm} \leq W \leq 0.1 \text{ mm}$ $L \leq 10\text{mm}$</td> <td>5</td> </tr> <tr> <td>$W < 0.05\text{mm}$</td> <td>*</td> </tr> </tbody> </table>	Zone Dimension	Acceptable number	Class of Defects	$W > 0.1\text{mm}$ or $L > 10\text{mm}$	0	Minor	$0.05 \text{ mm} \leq W \leq 0.1 \text{ mm}$ $L \leq 10\text{mm}$	5	$W < 0.05\text{mm}$	*	 <p>L : Long W : Width</p>		
Zone Dimension	Acceptable number	Class of Defects												
$W > 0.1\text{mm}$ or $L > 10\text{mm}$	0	Minor												
$0.05 \text{ mm} \leq W \leq 0.1 \text{ mm}$ $L \leq 10\text{mm}$	5													
$W < 0.05\text{mm}$	*													
Non-uniformity	Visible through 5 %ND filter White, R, G, B and gray 50% pattern.	(Minor)												
Dimension	Outline	(Major)												
Bezel appearance	uneven	(Minor)												

<p>Scratch on the Touch panel</p>	<table border="1"> <thead> <tr> <th>Zone \ Dimension</th> <th>Acceptable number</th> <th>Class of Defects</th> </tr> </thead> <tbody> <tr> <td>$W > 0.1\text{mm}$ or $L > 10\text{mm}$</td> <td>0</td> <td rowspan="2">Minor</td> </tr> <tr> <td>$W \leq 0.1\text{ mm}$ $L \leq 10\text{mm}$</td> <td>5</td> </tr> </tbody> </table>	Zone \ Dimension	Acceptable number	Class of Defects	$W > 0.1\text{mm}$ or $L > 10\text{mm}$	0	Minor	$W \leq 0.1\text{ mm}$ $L \leq 10\text{mm}$	5	
Zone \ Dimension	Acceptable number	Class of Defects								
$W > 0.1\text{mm}$ or $L > 10\text{mm}$	0	Minor								
$W \leq 0.1\text{ mm}$ $L \leq 10\text{mm}$	5									
<p>Dent on the Touch panel</p>	<table border="1"> <thead> <tr> <th>Zone \ Dimension</th> <th>Acceptable number</th> <th>Class of Defects</th> </tr> </thead> <tbody> <tr> <td>$D > 0.5\text{ mm}$</td> <td>0</td> <td rowspan="2">Minor</td> </tr> <tr> <td>$0.3\text{mm} \leq D \leq 0.5\text{ mm}$</td> <td>5</td> </tr> </tbody> </table>	Zone \ Dimension	Acceptable number	Class of Defects	$D > 0.5\text{ mm}$	0	Minor	$0.3\text{mm} \leq D \leq 0.5\text{ mm}$	5	 <p style="text-align: center;">$D = (L + W) / 2$</p>
Zone \ Dimension	Acceptable number	Class of Defects								
$D > 0.5\text{ mm}$	0	Minor								
$0.3\text{mm} \leq D \leq 0.5\text{ mm}$	5									
<p>Polarizer flaw or leak out resin</p>	<p>Defect is defined as the active area.</p>									
<p>Corner Chipping</p>	<p>$X < 3\text{ mm}$, $Y < 3\text{ mm}$, $Z < \text{Glass thickness}$</p>									
<p>Edge Chipping</p>	<p>$X < 3\text{ mm}$, $Y < 3\text{ mm}$, $Z < \text{Glass thickness}$</p>									
<p>Crack</p>	<p>reject</p>									

12.4 Sampling Condition

Unless otherwise agree in written, the sampling inspection shall be applied to the incoming inspection of customer.

Lot size: Quantity of shipment lot per model.

Sampling type: normal inspection, single sampling

Sampling table: MIL-STD-105E

Inspection level: Level II

Class of defects	Definition		
	Major	AQL 0.65%	It is a defect that is likely to result in failure or to reduce materially the usability of the product for the intended function.
Minor	AQL 1.5%	It is a defect that will not result in functioning problem with deviation classified.	

Note:1. (a)Bright point defect is defined as point defect of R,G,B with area $> 1/2$ pixel respectively

(b)Dark point defect is defined as visible in full white pattern.

(c)Definition of distribution of point defect is as follows:

- minimum separation between dark point defects should be larger than 5mm.
- minimum separation between bright point defects should be larger than 5mm.

(d) Definition of joined bright point defect and joined dark point defect are as follows:

- Three or more joined bright point defects must be nil.
- Three joined dark point defects must be nil.
- Two Joined dark point is counted as two dark points with 2 pair maximum.

(e) Line defect is defined as visible by using 5 % ND filter.

Note:2 Luminance measurement for contrast ratio is at the distance 50 ± 5 cm between the detective head and the panel with ambient illuminance less than 1 lux. Contrast ratio is obtained at optimum view angle

13. LCM NUMBERING SYSTEM

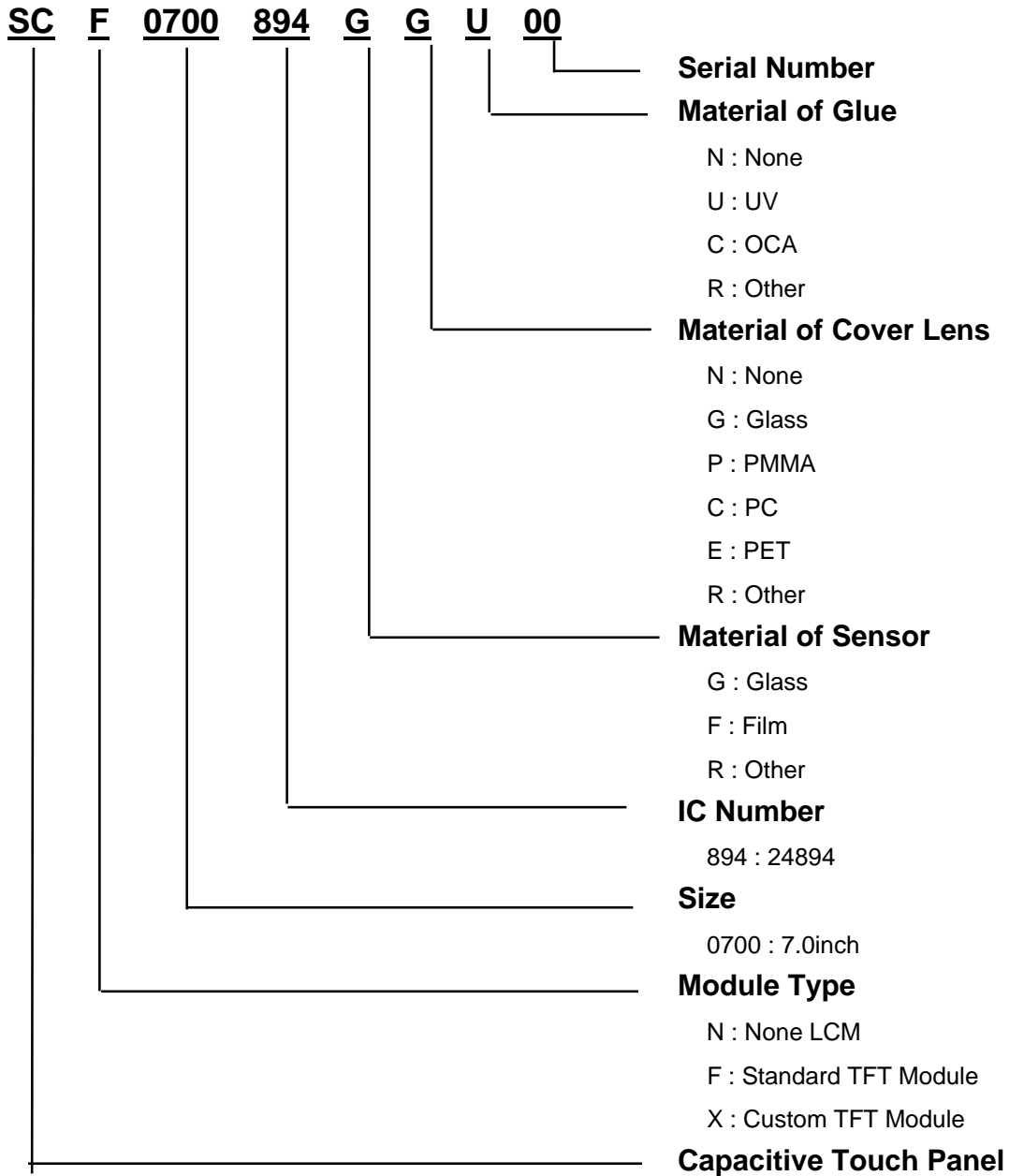

14. PRECAUTIONS IN USE LCM

1. LIQUID CRYSTAL DISPLAY (LCD)

LCD is made up of glass, organic sealant, organic fluid, and polymer based polarizers. The following precautions should be taken when handling,

- (1). Keep the temperature within range of use and storage. Excessive temperature and humidity could cause polarization degradation, polarizer peel off or bubble.
- (2). Do not contact the exposed polarizers with anything harder than an HB pencil lead. To clean dust off the display surface, wipe gently with cotton, chamois or other soft material soaked in petroleum benzin.
- (3). Wipe off saliva or water drops immediately. Contact with water over a long period of time may cause polarizer deformation or color fading, while an active LCD with water condensation on its surface will cause corrosion of ITO electrodes.
- (4). Glass can be easily chipped or cracked from rough handling, especially at corners and edges.
- (5). Do not drive LCD with DC voltage.

2. Liquid Crystal Display Modules

2.1 Mechanical Considerations

LCM are assembled and adjusted with a high degree of precision. Avoid excessive shocks and do not make any alterations or modifications. The following should be noted.

- (1). Do not tamper in any way with the tabs on the metal frame.
- (2). Do not modify the PCB by drilling extra holes, changing its outline, moving its components or modifying its pattern.
- (3). Do not touch the elastomer connector, especially insert an backlight panel (for example, EL).
- (4). When mounting a LCM make sure that the PCB is not under any stress such as bending or twisting. Elastomer contacts are very delicate and missing pixels could result from slight dislocation of any of the elements.
- (5). Avoid pressing on the metal bezel, otherwise the elastomer connector could be deformed and lose contact, resulting in missing pixels.

2.2. Static Electricity

LCM contains CMOS LSI's and the same precaution for such devices should apply, namely

- (1). The operator should be grounded whenever he/she comes into contact with the module. Never touch any of the conductive parts such as the LSI pads, the copper leads on the PCB and the interface terminals with any parts of the human body.
- (2). The modules should be kept in antistatic bags or other containers resistant to static for storage.
- (3). Only properly grounded soldering irons should be used.
- (4). If an electric screwdriver is used, it should be well grounded and shielded from commutator sparks.

- (5) The normal static prevention measures should be observed for work clothes and working benches; for the latter conductive (rubber) mat is recommended.
- (6). Since dry air is inductive to statics, a relative humidity of 50-60% is recommended.

2.3 Soldering

- (1). Solder only to the I/O terminals.
- (2). Use only soldering irons with proper grounding and no leakage.
- (3). Soldering temperature : $280^{\circ}\text{C} \pm 10^{\circ}\text{C}$
- (4). Soldering time: 3 to 4 sec.
- (5). Use eutectic solder with resin flux fill.
- (6). If flux is used, the LCD surface should be covered to avoid flux spatters. Flux residue should be removed after wards.

2.4 Operation

- (1). The viewing angle can be adjusted by varying the LCD driving voltage V_0 .
- (2). Driving voltage should be kept within specified range; excess voltage shortens display life.
- (3). Response time increases with decrease in temperature.
- (4). Display may turn black or dark blue at temperatures above its operational range; this is (however not pressing on the viewing area) may cause the segments to appear "fractured".
- (5). Mechanical disturbance during operation (such as pressing on the viewing area) may cause the segments to appear "fractured".

2.5 Storage

If any fluid leaks out of a damaged glass cell, wash off any human part that comes into contact with soap and water. Never swallow the fluid. The toxicity is extremely low but caution should be exercised at all the time.

2.6 Limited Warranty

Unless otherwise agreed between DATA IMAGE and customer, DATA IMAGE will replace or repair any of its LCD and LCM which is found to be defective electrically and visually when inspected in accordance with DATA IMAGE acceptance standards, for a period on one year from date of shipment. Confirmation of such date shall be based on freight documents. The warranty liability of DATA IMAGE is limited to repair and/or replacement on the terms set forth above. DATA IMAGE will not responsible for any subsequent or consequential events.

Confidential Document
15. OUTLINE DRAWING

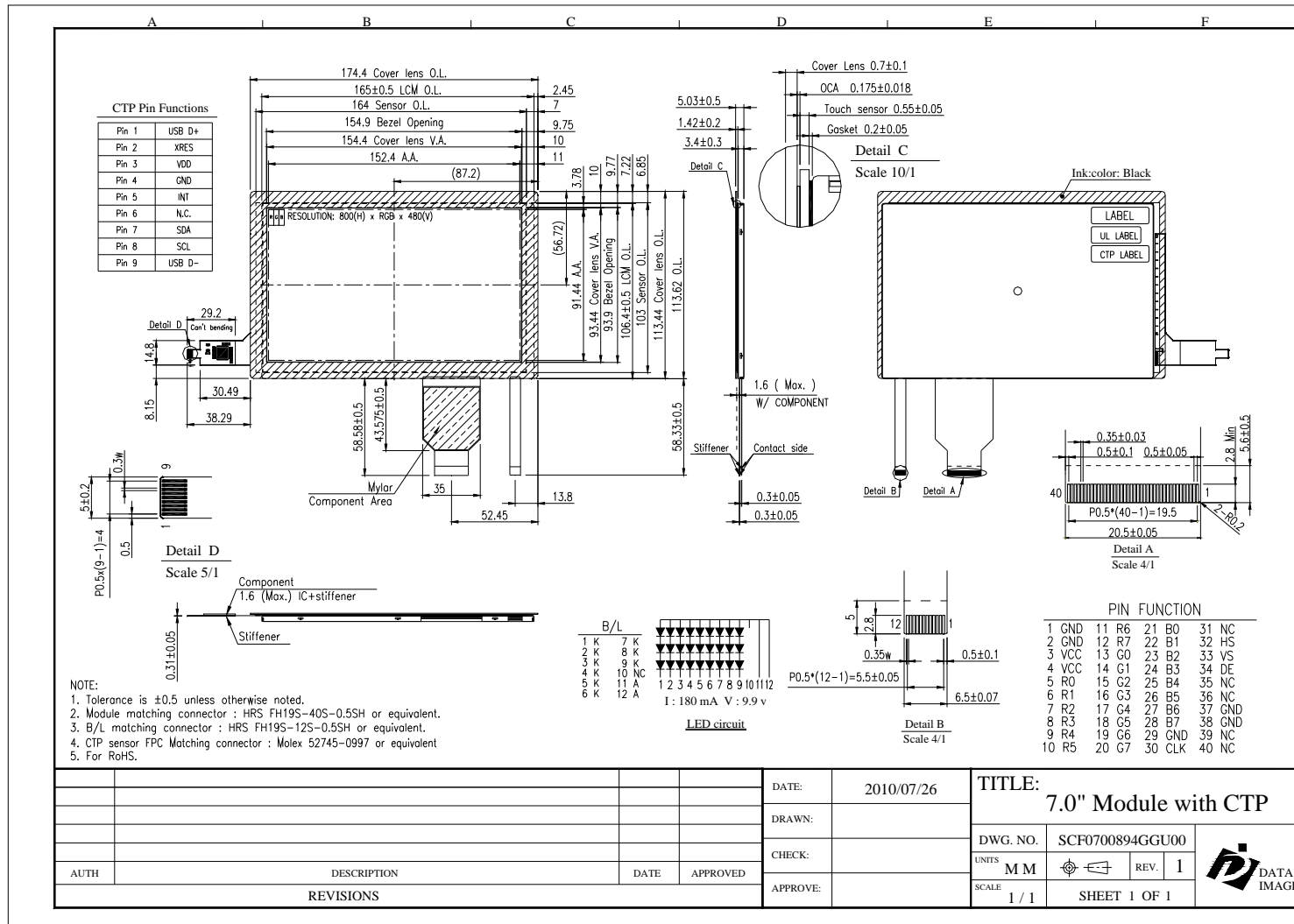

16.PACKAGE INFORMATION

T.B.D