

# Multimedia SoCs **Voyager/Lynx Family**

Silicon Motion offers two family of graphics processor unit (GPU), the Lynx family and the Voyager family, to enable embedded and consumer applications such as high resolution handhelds, Point-of-Sales terminals, medical device, multi-functional printer, casino gaming, IPC, server, etc.

Leveraging over 10 years of low power graphics experience, Silicon Motion's GPU products are packaged in multi-chip module (MCM) with embedded video memory to provide cost effective and low power consumption as well as longevity solution. The integration of the graphics fundamentals provides outstanding reliability and flexibility across multiple applications.

## Voyager Family

The Voyager family is designed to complement needs for the vertical market with flexible bus interface for a wide range of embedded CPUs, which include x86, Xscale, ARM7/9/11, MIPS-license CPUs, Renesas SH, and PowerPC. To help reduce total system costs, the Voyager family equips variety of I/O, including analog RGB and digital LCD panel interfaces, USB host, UART, AC97/I2S, Zoom Video, PWM, SSP and GPIO for interfacing external devices. The rich software debug and SDK tools simplify the driver development of utilizing the 7 graphic display layers and multiple display function for high quality and sophisticate applications.

## Lynx Family

The Lynx family provides server GPU solution for x86 and PowerPC based platform via PCI, AGP and PCIe bus interface. The Lynx family provides the best of the class in power consumption, dual display, hardware rotation and ReduceOn™ feature. The ReduceOn™ technology is the intelligent power management core to algorithmically vary the clock to functional units while disabling the unused units and therefore, resulting in dramatic reduction in average operating power usage without compromising multimedia quality or performance. The comprehensive software driver, reliable hardware and rich feature provide confidence and assurance for applications, such as Server, IPC, Thin Client and Point-of-Sales.

SM502 Block Diagram

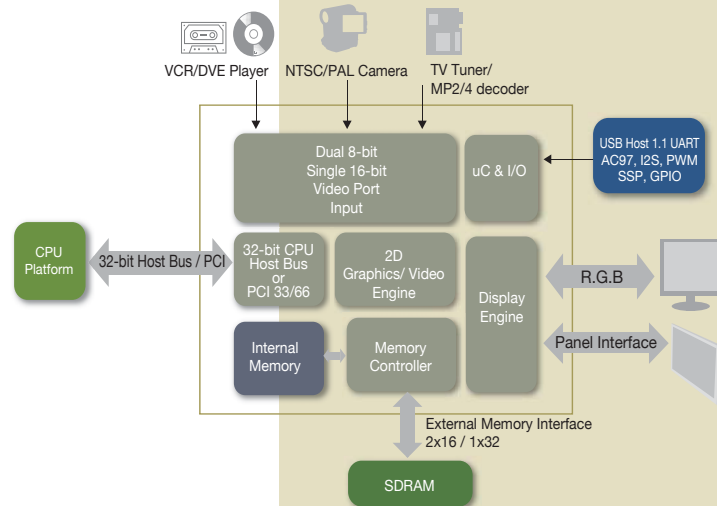

SM750 Block Diagram

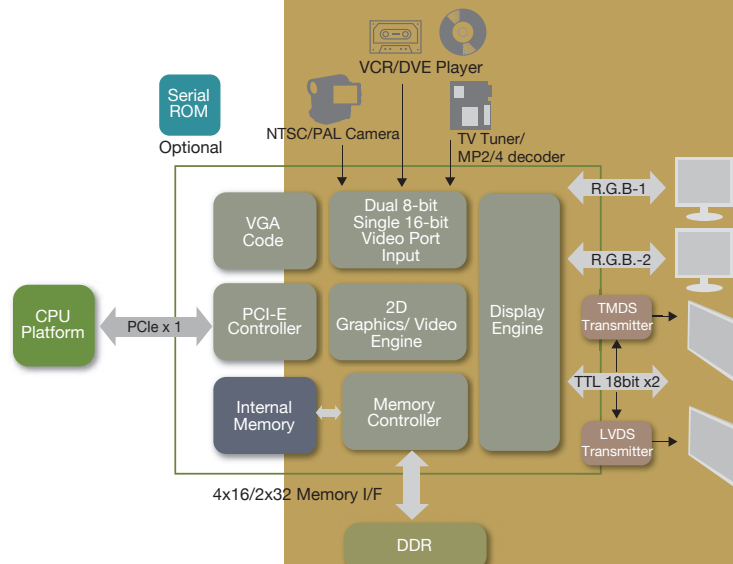

## Voyager Family-Embedded GPU

| Parameter         |                          | SM502   | SM107   |
|-------------------|--------------------------|---|---|
| Host bus          | 32-bit local bus         | Yes   | Yes   |
|                   | PCI                      | Yes   | Yes   |
|                   | AGP 2X                   | --  | --  |
|                   | PCIe X1                  | --  | --  |
| Memory            | Memory type              | SDRAM   | SDRAM   |
|                   | Internal memory size     | 0, 8MB  | 4MB   |
|                   | Max. Ext. memory size    | 64MB  | N/A   |
| Graphic engine    | 2D/3D                    | 2D  | 2D  |
| Display interface | Integrated TV encoder    | Digital RGB Output  | Digital RGB Output  |
|                   | Panel interface          | Up to 24-bit STN/TFT  | Up to 24-bit STN/TFT  |
|                   | Resolution               | 1280x1024 (4:3); 1366x768 (16:9)  | 1280x1024 (4:3); 1366x768 (16:9)  |
|                   | Color depth              | 16/32 bpp   | 16/32 bpp   |
|                   | Dual display / adapter   | Yes   | Yes   |
|                   | CRT DAC speed            | 240MHz  | 240MHz  |
| Others            | HW screen rotation       | Yes   | Yes   |
|                   | I/O peripherals          | USB Host, UART, AC97, I2C, PWM, SSP, GPIO, Dual 8-bit/Single 16-bit ZV Port   | Dual 8-bit/Single 16-bit ZV Port  |
|                   | Display layer            | 7   | 7   |
| Software driver   | Operating systems        | WinCE/XPe, Linux, VxWork, QNX   | WinCE/XPe, Linux, VxWork, QNX   |
| CPU platform      | X86 / PCI interface      | Intel x86/IXP4xx; AMD x86 AU1xxx; Marvell M5281; ZFMicro ZFx86; STMicro Longson; AMCC 405/440 PPC; BLX Godson; Toshiba MIPS | Intel x86/IXP4xx; AMD x86 AU1xxx; Marvell M5281; ZFMicro ZFx86; STMicro Longson; AMCC 405/440 PPC; BLX Godson; Toshiba MIPS |
|                   | ARM (32-bit host bus)    | Marvell Xscale PXA25x/27x; Samsung S3C2410/S3C2440; Cirrus Logic EP9315; Freescale iMx21/27/31                              | Marvell Xscale PXA25x/27x; Samsung S3C2410/S3C2440; Cirrus Logic EP9315; Freescale iMx21/27/31                              |
|                   | MIPS (32-bit host bus)   | NEC VR4122/VR4131   | NEC VR4122/VR4131   |
|                   | SuperH (32-bit host bus) | Renesas SH3 /SH4 SH77xxR  | Renesas SH3 / SH4 SH77xxR   |

## Lynx Family-Server GPU

| Parameter         |                        | SM712  | SM722  | SM718  | SM750  |
|-------------------|------------------------|--|--|--|--|
| Host bus          | 32-bit local bus       | --   | --   | Yes  | --   |
|                   | PCI                    | Yes  | Yes  | Yes  | --   |
|                   | AGP 2X                 | Yes  | Yes  | --   | --   |
|                   | PCIe X1                | --   | --   | --   | Yes  |
| Memory            | Memory type            | SDRAM  | SDRAM  | DDR  | DDR  |
|                   | Internal memory size   | 4MB  | 8MB  | 0, 16MB  | 0, 16MB  |
|                   | Max. Ext. memory size  | N/A  | N/A  | 64MB   | 64MB   |
| Graphic engine    | 2D/3D                  | 2D   | 2D/3D  | 2D   | 2D   |
| Display interface | Integrated TV encoder  | --   | Yes  | --   | --   |
|                   | Panel interface        | Up to 24-bit STN/TFT   | Up to 24-bit + 1 LVDS channel STN/TFT                          | Up to 36-bit (share pins) STN/TFT                                    | Up to 36-bit STN/TFT   |
|                   | Resolution             | 1280x1024  | 1280x1024  | 1920x1440  | 1920x1440  |
|                   | Color depth            | 8/16/24 bpp  | 8/16/24 bpp  | 8/16/32 bpp  | 8/16/32 bpp  |
|                   | Dual display / adapter | Yes  | Yes  | Yes  | Yes  |
|                   | CRT DAC speed          | 170MHz   | 170MHz   | 300MHz   | 300MHz   |
| Others            | HW screen rotation     | Yes  | Yes  | Yes  | Yes  |
|                   | I/O peripherals        | 16-bit ZV Port   | 16-bit ZV Port   | Dual 8-bit / Single 16-bit ZV Port                                   | Dual 8-bit / Single 16-bit ZV Port                                   |
|                   | Display layer          | 4  | 4  | 7  | 7  |
| Power management  | ReduceOn™              | Yes  | Yes  | Yes  | Yes  |
|                   | ACPI compliant         | Yes  | Yes  | Yes  | Yes  |
| Software driver   | Operating systems      | Win9x/NT/2K/CE, WinXP/Vista, Win2003 (x32/x64), Linux Enterprise (x32/x64) | Win9x/NT/2K/CE, WinXP/Vista, Linux                             | Win2K/CE, WinXP/Vista, Win2003 (x32/x64), Linux Enterprise (x32/x64) | Win2K/CE, WinXP/Vista, Win2003 (x32/x64), Linux Enterprise (x32/x64) |
| CPU platform      | X86 / PCI interface    | Intel x86/IXP4xx; AMD x86/AU1xxx; ZFMicro ZFx86; Freescale PPC             | Intel x86/IXP4xx; AMD x86/AU1xxx; ZFMicro ZFx86; Freescale PPC | Intel x86/IXP4xx; AMD x86/AU1xxx; ZFMicro ZFx86; Freescale PPC       | Intel x86/IXP4xx; AMD x86/AU1xxx; ZFMicro ZFx86; Freescale PPC       |