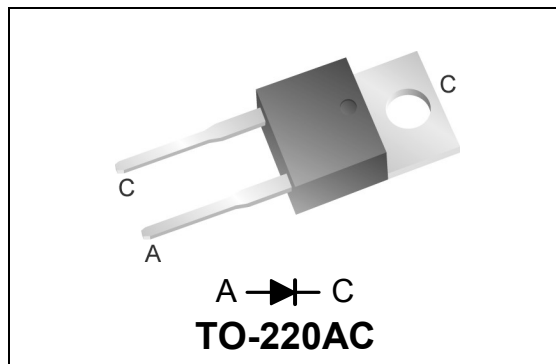


## 300V, 16A Q-Series Rectifier

### Product Summary

$I_{F(AVG)}$	16	A
$V_{RRM}$	300	V
$Q_{RR}$ (Typ at 125 °C)	44	nC
$I_{RRM}$ (Typ at 125 °C)	2.65	A
Softness $t_b/t_a$ (Typ at 125 °C)	0.7	

### Pin Assignment



### RoHS Compliant

Package uses Lead-free plating and Green mold compound.

### General Description

Utilizing proprietary Qspeed technology this device has the lowest  $Q_{RR}$  of any 300V Silicon diode. Its recovery characteristics increase efficiency, reduce EMI and eliminate snubbers.

### Applications

- AC/DC and DC/DC output rectification
  - Output and freewheeling diodes
- DC-AC Inverters

### Features

- Low  $Q_{RR}$ , Low  $I_{RRM}$ , Low  $t_{RR}$
- High  $di_F/dt$  capable (1000A/ $\mu$ s)
- Soft recovery

### Benefits

- Increases efficiency
  - Eliminates need for snubber circuits
  - Reduces EMI filter component size & count
- Enables extremely fast switching

### Absolute Maximum Ratings

Absolute maximum ratings are the values beyond which the device may be damaged or have its useful life impaired. Functional operation under these conditions is not implied.

Symbol	Parameter	Conditions	Rating	Units
$V_{RRM}$	Peak repetitive reverse voltage		300	V
$I_{F(AVG)}$	Average forward current	$T_J = 150\text{ °C}$ , $T_C = 122\text{ °C}$	16	A
$I_{FSM}$	Non-repetitive peak surge current	60 Hz, 1/2 cycle	100	A
$I_{FSM}$	Non-repetitive peak surge current	1/2 cycle of $t=28\text{ }\mu$ s Sinusoid, $T_C=25\text{ °C}$	350	A
$T_{J(MAX)}$	Maximum junction temperature		150	°C
$T_{STG}$	Storage temperature		-55 to 150	°C
	Lead soldering temperature	Leads at 1.6 mm from case, 10 sec	300	°C
$P_D$	Power dissipation	$T_C = 25\text{ °C}$	65.8	W

### Thermal Resistance

Symbol	Resistance from:	Conditions	Rating	Units
$R_{\theta JA}$	Junction to ambient	TO-220	62	°C/W
$R_{\theta JC}$	Junction to case	TO-220	1.9	°C/W

Ihr Vertriebspartner:  
**HY-LINE**<sup>®</sup>  
POWER COMPONENTS

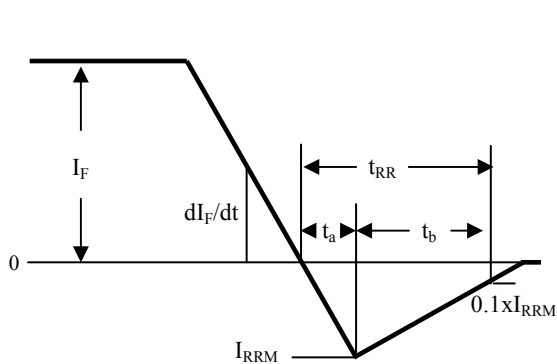
Inselkammerstraße 10  
D-82008 Unterhaching  
Tel.: +49 (0)89 614503 10  
Fax: +49 (0)89 614503 20  
E-Mail: [power@hy-line.de](mailto:power@hy-line.de)  
URL: [www.hy-line.de](http://www.hy-line.de)

Gründenstrasse 10  
CH-8247 Flurlingen  
Tel.: +41 (0)52 647 42 00  
Fax: +41 (0)52 647 42 01  
E-Mail: [power@hy-line.ch](mailto:power@hy-line.ch)  
URL: [www.hy-line.ch](http://www.hy-line.ch)

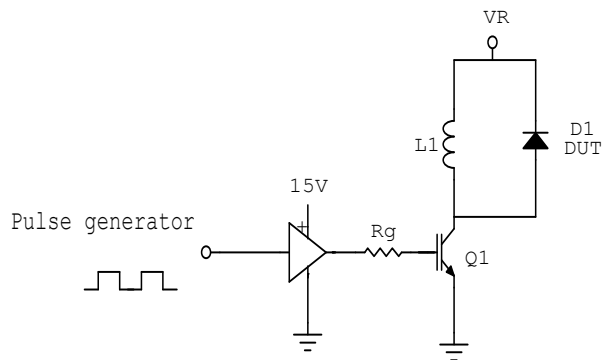
**Electrical Specifications at T<sub>J</sub> = 25 °C (unless otherwise specified)**

Symbol	Parameter	Conditions	Min	Typ	Max	Units	
<b>DC Characteristics</b>							
I <sub>R</sub>	Reverse current	V <sub>R</sub> = 300V, T <sub>J</sub> = 25 °C	-	-	25	μA	
		V <sub>R</sub> = 300V, T <sub>J</sub> = 125 °C	-	0.45	-	mA	
V <sub>F</sub>	Forward voltage	I <sub>F</sub> = 16A, T <sub>J</sub> = 25 °C	-	1.6	1.9	V	
		I <sub>F</sub> = 16A, T <sub>J</sub> = 150 °C	-	1.4	-	V	
C <sub>J</sub>	Junction capacitance	V <sub>R</sub> = 10V, 1 MHz	-	50	-	pF	
<b>Dynamic Characteristics</b>							
t <sub>RR</sub>	Reverse recovery time	dI/dt = 200A/μs V <sub>R</sub> = 200V, I <sub>F</sub> = 16A	T <sub>J</sub> = 25 °C	-	13	-	ns
			T <sub>J</sub> = 125 °C	-	25	-	ns
Q <sub>RR</sub>	Reverse recovery charge	dI/dt = 200A/μs V <sub>R</sub> = 200V, I <sub>F</sub> = 16A	T <sub>J</sub> = 25 °C	-	11.5	15	nC
			T <sub>J</sub> = 125 °C	-	44	-	nC
I <sub>RRM</sub>	Maximum reverse recovery current	dI/dt = 200A/μs V <sub>R</sub> = 200V, I <sub>F</sub> = 16A	T <sub>J</sub> = 25 °C	-	1.5	1.85	A
			T <sub>J</sub> = 125 °C	-	2.65	-	A
S	Softness factor = $\frac{t_b}{t_a}$	dI/dt = 200A/μs V <sub>R</sub> = 200V, I <sub>F</sub> = 16A	T <sub>J</sub> = 25 °C	-	0.7	-	
			T <sub>J</sub> = 125 °C	-	0.7	-	

**Note to component engineers:** Qspeed Q-Series rectifiers employ Schottky technologies in their design and construction. Therefore, Component Engineers should plan their test setups to be similar to those for traditional Schottky test setups. (For additional details, see Qspeed Application Note AN-300.)

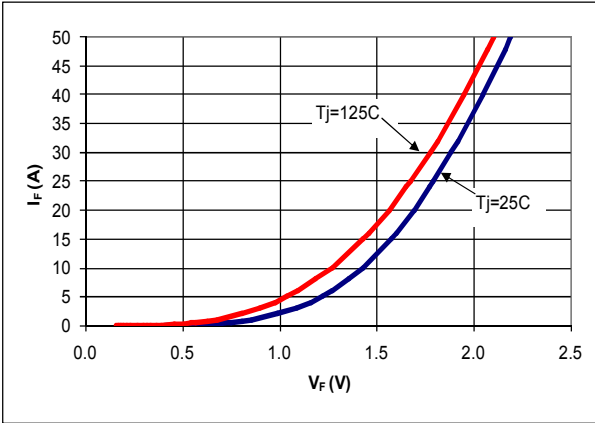


**Figure 1. Reverse Recovery Definitions**

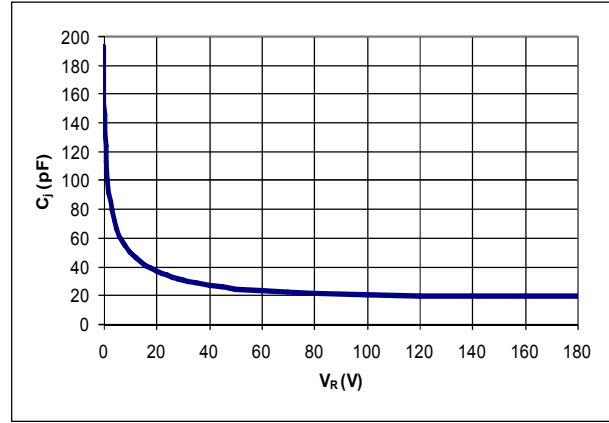


**Figure 2. Reverse Recovery Test Circuit**

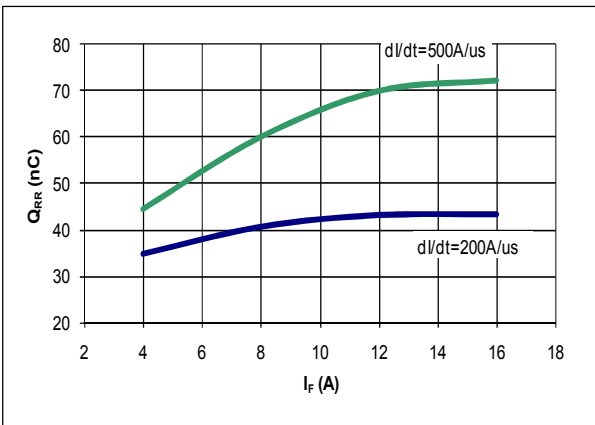
**Electrical Specifications at  $T_J = 25\text{ }^\circ\text{C}$  (unless otherwise specified)**



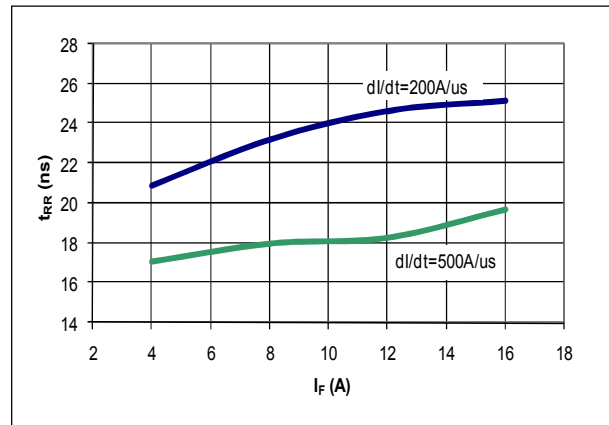
**Figure 3. Typical  $I_F$  vs  $V_F$**



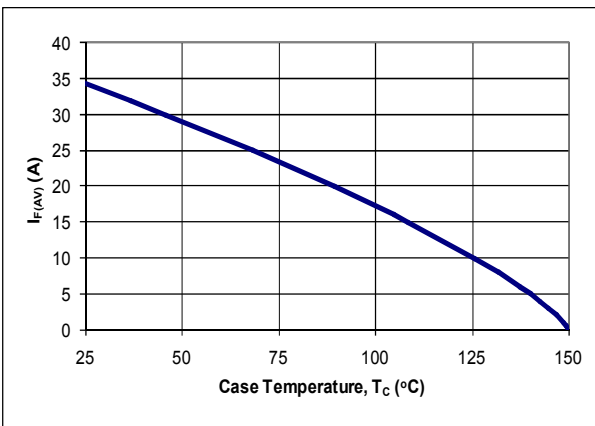
**Figure 4. Typical  $C_J$  vs  $V_R$**



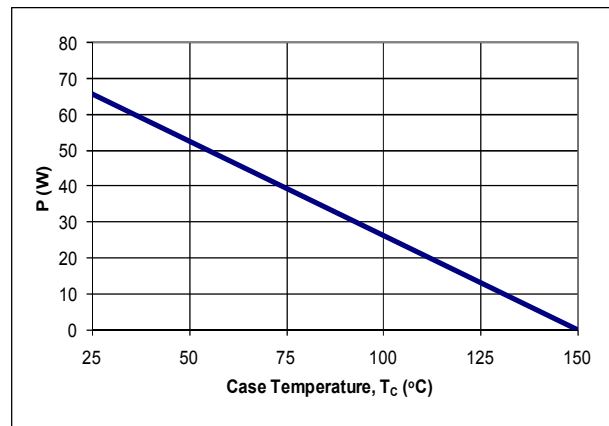
**Figure 5. Typical  $Q_{RR}$  vs  $I_F$  at  $T_J = 125\text{ }^\circ\text{C}$**



**Figure 6. Typical  $t_{RR}$  vs  $I_F$  at  $T_J = 125\text{ }^\circ\text{C}$**



**Figure 7. DC Current Derating Curve**



**Figure 8. Power Derating Curve**

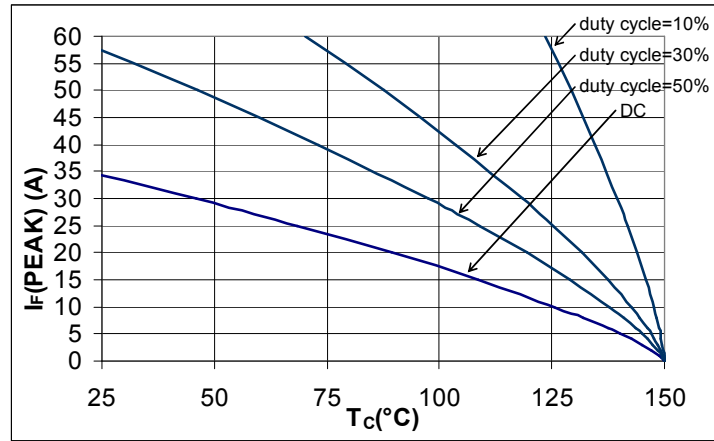


Figure 9. I<sub>F</sub>(PEAK) vs T<sub>C</sub>, f=70 kHz

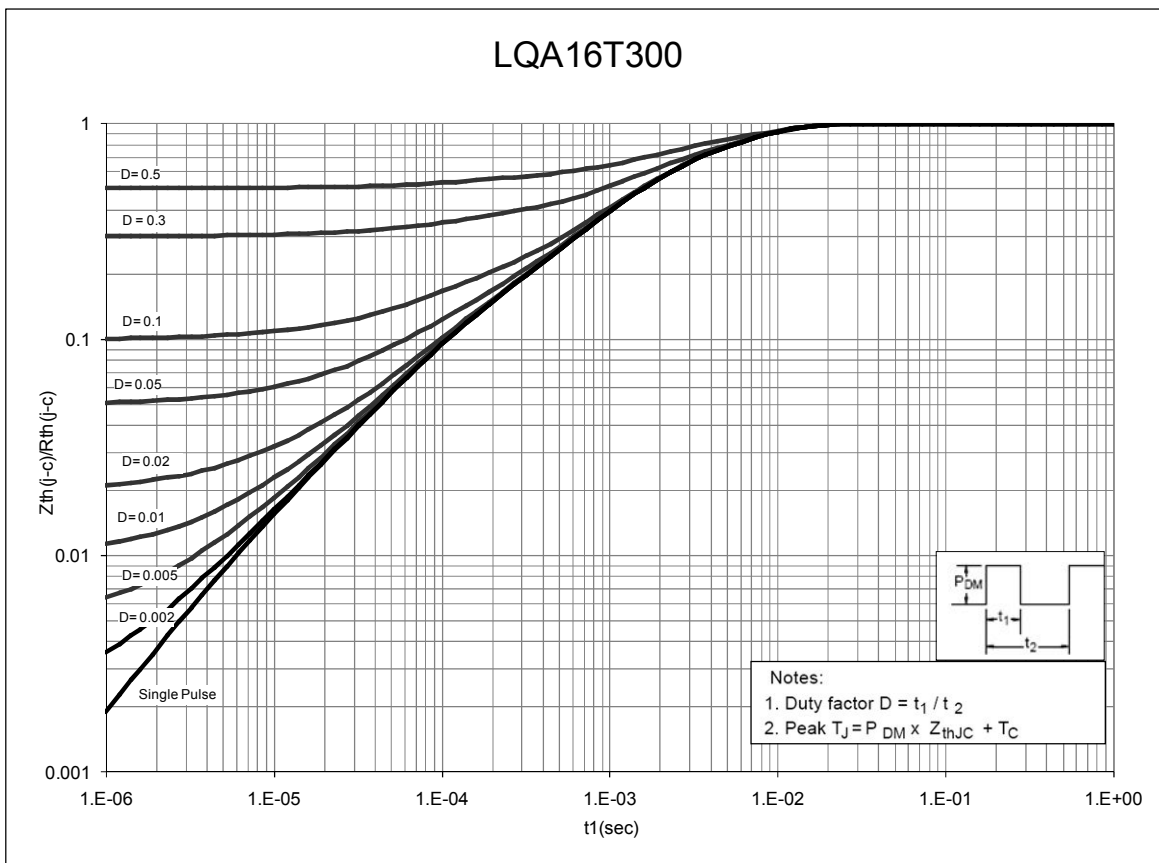
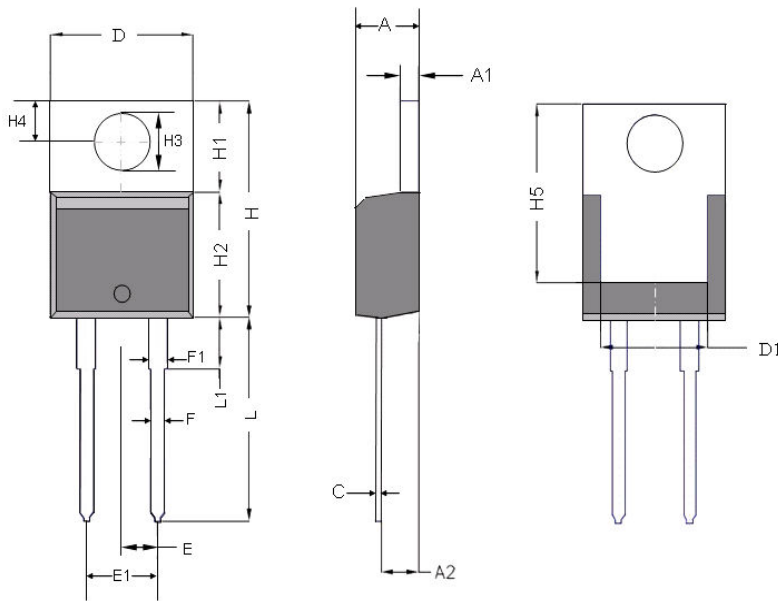


Figure 10. Normalized Maximum Transient Thermal Impedance

**Dimensional Outline Drawings**



Dim	Millimeters	
	MIN	MAX
A	4.32	4.57
A1	1.14	1.40
A2	2.03	2.74
C	0.356	0.610
D	9.65	10.67
D1	7.57	7.67
E	2.49	2.59
E1	5.03	5.13
F	0.508	1.016
F1	1.14	1.78
H	14.71	16.51
H1	5.84	6.55
H2	8.51	9.02
H3	3.53	3.96
H4	2.54	3.05
H5	12.34	13.00
L	13.00	14.22
L1	-	6.35

**TO-220AC** package conforms to JEDEC outline TO-220AC

Mechanical Mounting Method	Maximum Torque / Pressure specification
Screw through hole in package tab	1 Newton Meter (nm) or 8.8 inch-pounds (lb-in)
Clamp against package body	12.3 kilogram-force per square centimeter (kgf/cm <sup>2</sup> ) or 175 lbf/in <sup>2</sup>

**Soldering time and temperature:** This product has been designed for use with high-temperature, lead-free solder. The component leads can be subjected to a maximum temperature of 300 °C, for up to 10 seconds. See Application Note AN-303, for more details.

**Ordering Information**

Part Number	Package	Packing
LQA16T300	TO-220AC	50 units/tube

The information contained in this document is subject to change without notice.

**LIFE SUPPORT POLICY**

This product is not designed for use in life support appliances, devices or systems where malfunction of the product may result in personal injury. Qspeed Semiconductor cannot be held liable for damages or injuries that might result from the failure of the Qspeed Semiconductor product in such applications.