

300 V, 20 A Q-Series Common-Cathode Rectifier

Product Summary

$I_{F(AVG)}$ per diode	10	A
V_{RRM}	300	V
Q_{RR} (Typ at 125 °C)	38	nC
I_{RRM} (Typ at 125 °C)	2.3	A
Softness t_b/t_a (Typ at 125 °C)	0.7	

Pin Assignment

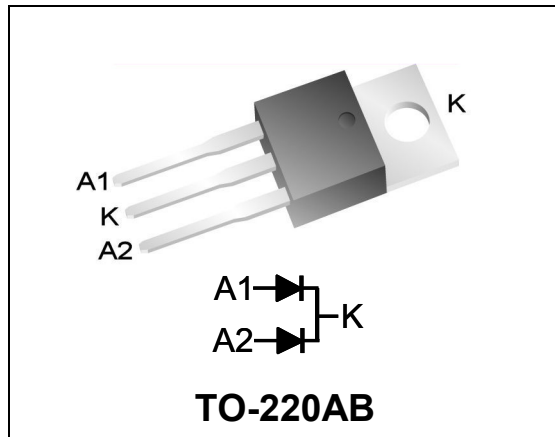

RoHS Compliant
Package uses Lead-free plating and "Green" mold compound

Ihr Vertriebspartner:
HY-LINE[®]
POWER COMPONENTS

Inselkammerstraße 10
D-82008 Unterhaching
Tel.: +49 (0)89 614503 10
Fax: +49 (0)89 614503 20
E-Mail: power@hy-line.de
URL: www.hy-line.de

Gründenstrasse 10
CH-8247 Flurlingen
Tel.: +41 (0)52 647 42 00
Fax: +41 (0)52 647 42 01
E-Mail: power@hy-line.ch
URL: www.hy-line.ch

General Description

Utilizing proprietary Qspeed technology this device has the lowest Q_{RR} of any 300 V Silicon diode. Its recovery characteristics increase efficiency, reduce EMI and eliminate snubbers.

Applications

- AC/DC and DC/DC output rectification
 - Output & freewheeling diodes
- Motor control drive circuits
- Uninterruptible Power Supply (UPS) inverters

Features

- Low Q_{RR} , Low I_{RRM} , Low t_{RR}
- High dI_F/dt capable (1000 A/ μ s)
- Soft recovery

Benefits

- Increases efficiency
 - Eliminates need for snubber circuits
 - Reduces EMI filter component size & count
- Enables extremely fast switching

Absolute Maximum Ratings

Absolute maximum ratings are the values beyond which the device may be damaged or have its useful life impaired. Functional operation under these conditions is not implied.

Symbol	Parameter	Conditions	Rating	Units
V_{RRM}	Peak repetitive reverse voltage		300	V
$I_{F(AVG)}$	Average forward current	Per Diode, $T_J = 150\text{ °C}$, $T_C = 115\text{ °C}$	10	A
		Per Device, $T_J = 150\text{ °C}$, $T_C = 115\text{ °C}$	20	A
I_{FSM}	Non-repetitive peak surge current	60 Hz, $\frac{1}{2}$ cycle	80	A
I_{FSM}	Non-repetitive peak surge current	$\frac{1}{2}$ cycle of $T = 28\text{ }\mu$ s Sinusoid, $T_C = 25\text{ °C}$	350	A
T_J	Maximum junction temperature		150	°C
T_{STG}	Storage temperature		-55 to 150	°C
	Lead soldering temperature	Leads at 1.6mm from case, 10 sec	300	°C
P_D	Power dissipation	$T_C = 25\text{ °C}$	52	W

Thermal Resistance

Symbol	Resistance from:	Conditions	Rating	Units
$R_{\theta JA}$	Junction to ambient	TO-220	62	°C/W
$R_{\theta JC}$	Junction to case	Per Diode	2.4	°C/W
		Per Device	1.2	°C/W

Electrical Specifications @T_J= 25 °C (unless otherwise specified)

Symbol	Parameter	Conditions	Min	Typ	Max	Units	
DC Characteristics per diode							
I _R	Reverse current per diode	V _R = 300 V, T _J = 25 °C	-	-	25	μA	
		V _R = 300 V, T _J = 125 °C	-	0.32	-	mA	
V _F	Forward voltage per diode	I _F = 10 A, T _J = 25 °C	-	1.58	1.9	V	
		I _F = 10 A, T _J = 150 °C	-	1.36	-	V	
C _J	Junction capacitance per diode	V _R = 10 V, 1 MHz	-	33	-	pF	
Dynamic Characteristics per diode							
t _{RR}	Reverse recovery time, per diode	dI _F /dt =200 A/μs V _R =200, I _F =10 A	T _J =25 °C	-	12.6	-	ns
			T _J =125 °C	-	24	-	ns
Q _{RR}	Reverse recovery charge, per diode	dI _F /dt =200 A/μs V _R =200, I _F =10 A	T _J =25 °C	-	10.2	16	nC
			T _J =125 °C	-	38	-	nC
I _{RRM}	Maximum reverse recovery current, per diode	dI _F /dt =200 A/μs V _R =200, I _F =10 A	T _J =25 °C	-	1.3	1.7	A
			T _J =125 °C	-	2.3	-	A
S	Softness per diode= $\frac{t_b}{t_a}$	dI _F /dt =200 A/μs V _R =200, I _F =10 A	T _J =25 °C	-	0.7	-	
			T _J =125 °C	-	0.7	-	

Note to component engineers: Q-Series rectifiers employ Schottky technologies in their design and construction. Therefore, component engineers should plan their test setups to be similar to traditional Schottky test setups. (For further details, see Qspeed application note AN-300.)

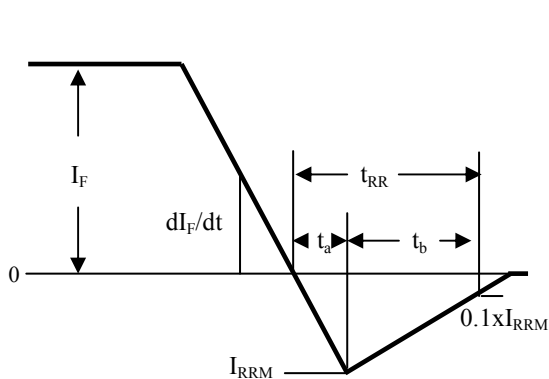

Figure 1. Reverse Recovery Definitions

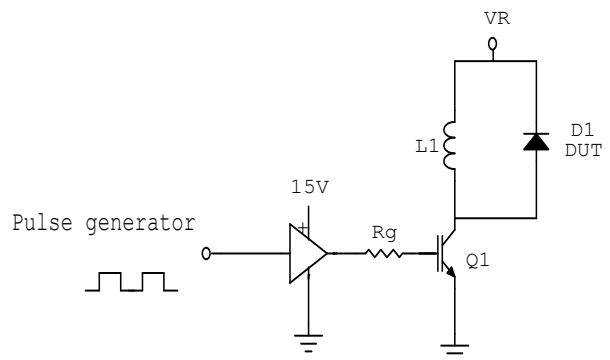

Figure 2. Reverse Recovery Test Circuit

Specifications per diode at $T_J = 25\text{ }^\circ\text{C}$ (unless otherwise specified)

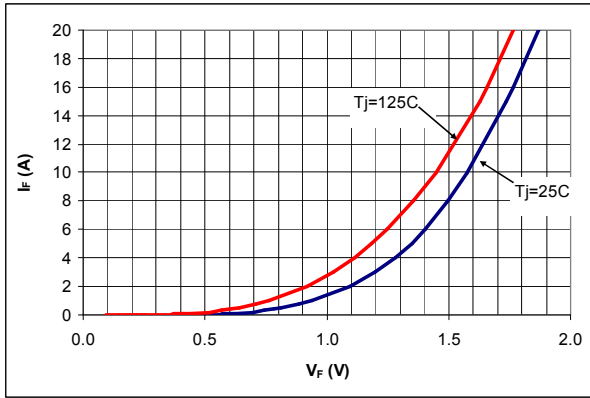

Figure 3. Typical I_F vs V_F

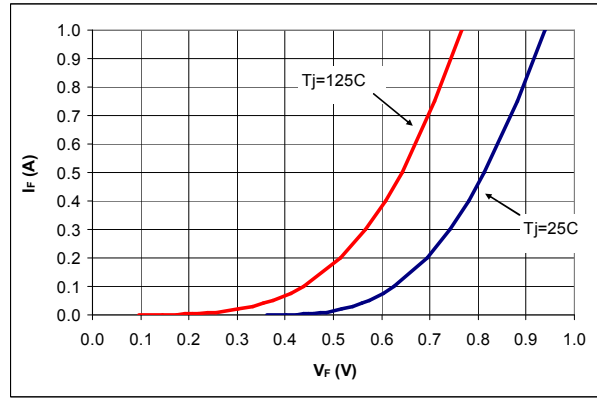

Figure 4. Typical I_F vs V_F

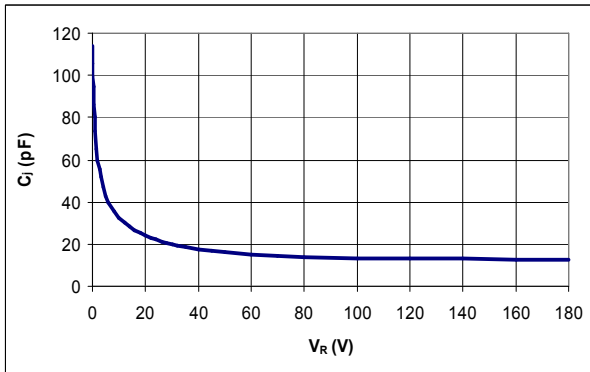

Figure 5. Typical C_j vs V_R

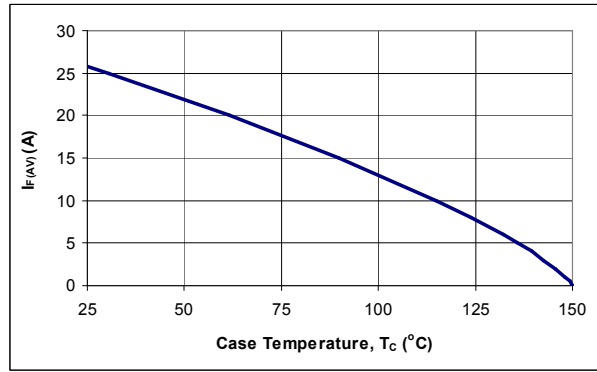

Figure 6. DC Current Derating Curve

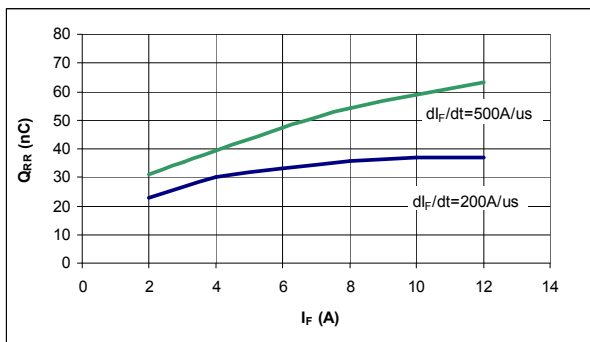

Figure 7. Typical Q_{RR} vs I_F at $T_J = 125\text{ }^\circ\text{C}$

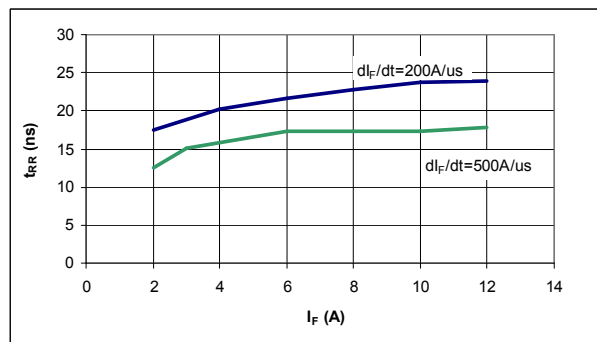

Figure 8. Typical t_{RR} vs I_F at $T_J = 125\text{ }^\circ\text{C}$

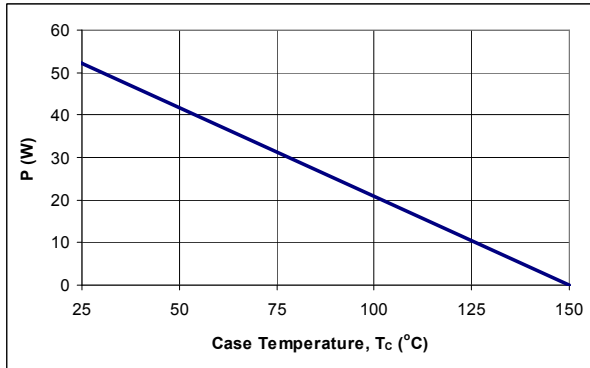

Figure 9. Power Derating Curve

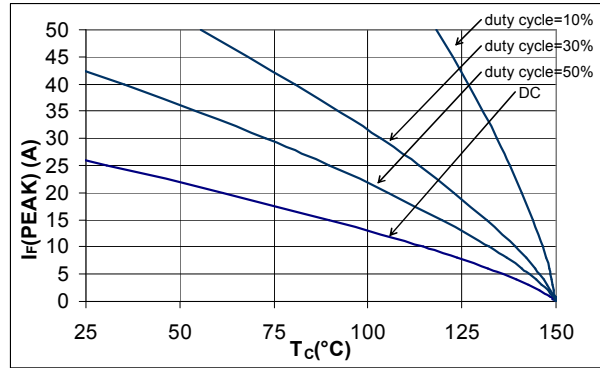

Figure 10. $I_F(\text{Peak})$ vs T_C , $f=70$ kHz

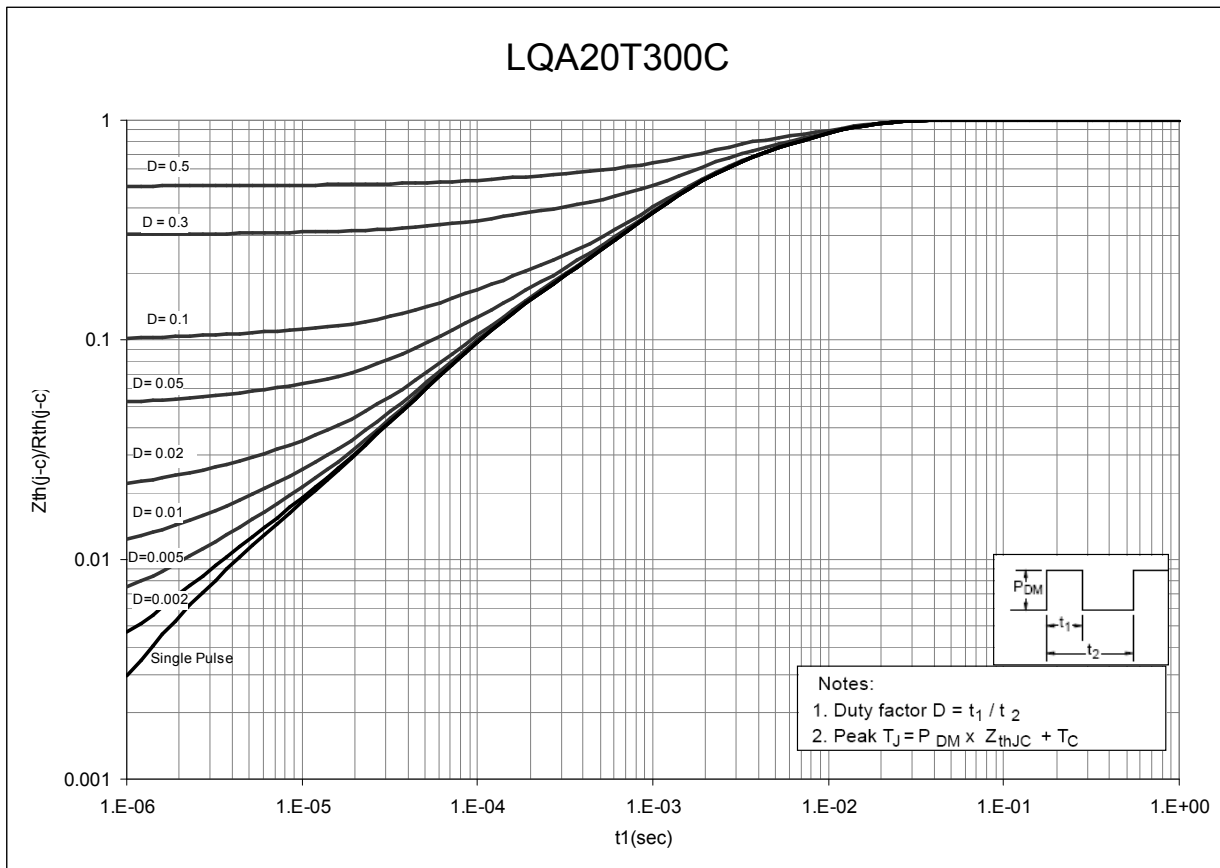
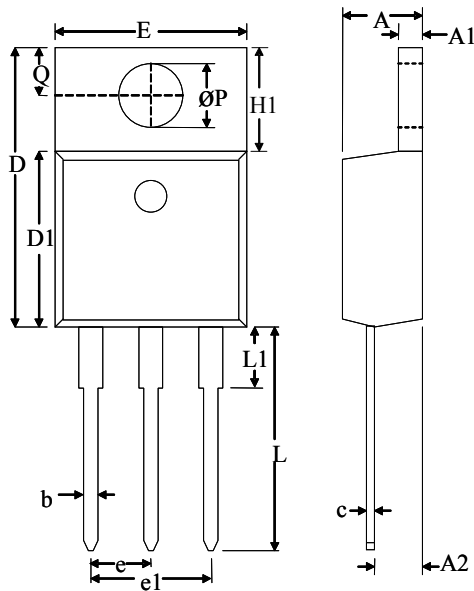

Figure 11. Normalized Maximum Transient Thermal Impedance

Dimensional Outline Drawings



Dim	Millimeters	
	MIN	MAX
A	4.32	4.70
A1	1.11	1.38
A2	2.59	2.79
b	0.77	1.00
c	0.34	0.47
D	14.71	15.75
D1	9.05	9.25
E	9.96	10.36
e	2.44	2.64
e1	4.98	5.18
H1	6.10	6.55
L	12.70	14.22
L1	–	3.90
ØP	3.71	3.96
Q	2.54	2.90

Mechanical Mounting Method	Maximum Torque / Pressure specification
Screw through hole in package tab	1 Newton Meter (nm) or 8.8 inch-pounds (lb-in)
Clamp against package body	12.3 kilogram-force per square centimeter (kgf/cm ²) or 175 lbf/in ²

Soldering time and temperature: This product has been designed for use with high-temperature, lead-free solder. The component leads can be subjected to a maximum temperature of 300 °C, for up to 10 seconds. See Application Note AN-303, for more details.

Ordering Information

Part Number	Package	Packing
LQA20T300C	TO-220AB	50 units/tube

The information contained in this document is subject to change without notice.

LIFE SUPPORT POLICY

This product is not designed for use in life support appliances, devices or systems where malfunction of the product may result in personal injury. Qspeed Semiconductor cannot be held liable for damages or injuries that might result from the failure of the Qspeed Semiconductor product in such applications.

Ihr Vertriebspartner:
HY-LINE[®]
POWER COMPONENTS

Inselkammerstraße 10
D-82008 Unterhaching
Tel.: +49 (0)89 614503 10
Fax: +49 (0)89 614503 20
E-Mail: power@hy-line.de
URL: www.hy-line.de

Gründenstrasse 10
CH-8247 Flurlingen
Tel.: +41 (0)52 647 42 00
Fax: +41 (0)52 647 42 01
E-Mail: power@hy-line.ch
URL: www.hy-line.ch