

AAT001-10E TMR Angle Sensor

Key Features

- Tunneling Magnetoresistance (TMR) Technology
- Very High Output Signal Without Amplification
- Wide Airgap Tolerance
- Very High Resistance for Extremely Low Power
- Sine and Cosine Outputs Available
- Ultraminiature TDFN6 Package

Typical Applications

- Rotary Encoders
- Automotive Rotary Position Sensors
- Motor Shaft Position Sensors
- Knob Position Sensors

Description

The AAT001-10E angle sensor is a unique array of four Tunneling Magnetoresistance (TMR) elements rotated at 90 degree intervals in the package and connected in a bridge configuration. The output can be configured to represent the sine and cosine functions of the magnetic field applied to the sensor. Each TMR sensor element has a resistance of approximately 1.25 megaohms. Outputs are proportional to the supply voltage and peak-to-peak output voltages are much larger than other sensor technologies. The part is packaged in NVE's 2.5 mm x 2.5 mm x 0.8 mm TDFN6 surface mount package.

Operation

Each sensor elements contain two magnetic layers: a "pinned," or fixed direction layer; and a movable-direction, or "free" layer. The diagram below illustrates the configuration, using arrows to represent the two layers:

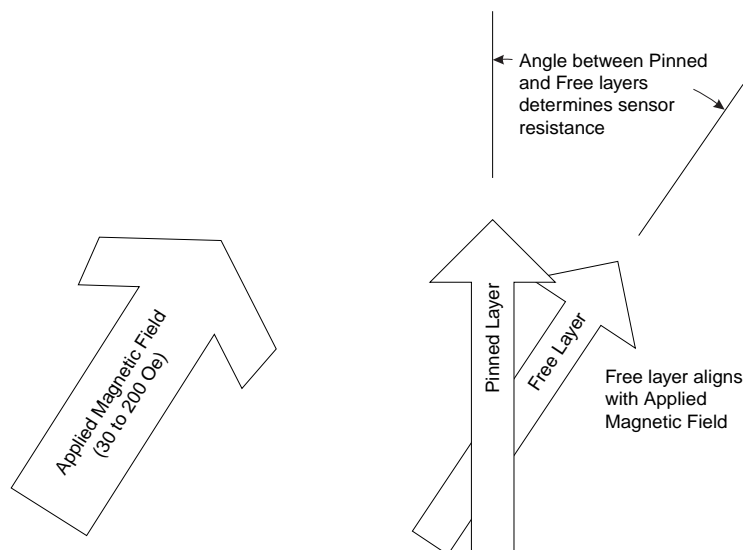

An external magnet provides a saturating magnetic field (30 to 200 Oe) in the plane of the sensor, as illustrated below for a bar magnet and a split-pole magnet:

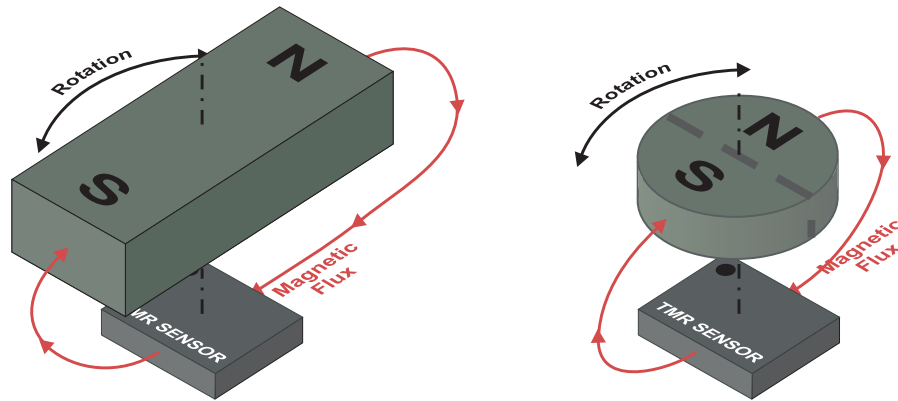

The sensor element free layers will align with the external field. As the applied field changes direction, the angle between the free layer and the pinned layer changes, changing the resistance of TMR elements, which changes the device output voltages.

Variations in the air gap between the magnet and the sensor element will cause slight changes in the output depending on the size and strength of the external magnet. The following chart shows a typical sensor output versus the angle of applied field using a 12 mm diameter, 4 mm thick split-pole ferrite magnet and a 5 V supply with three different air gaps:

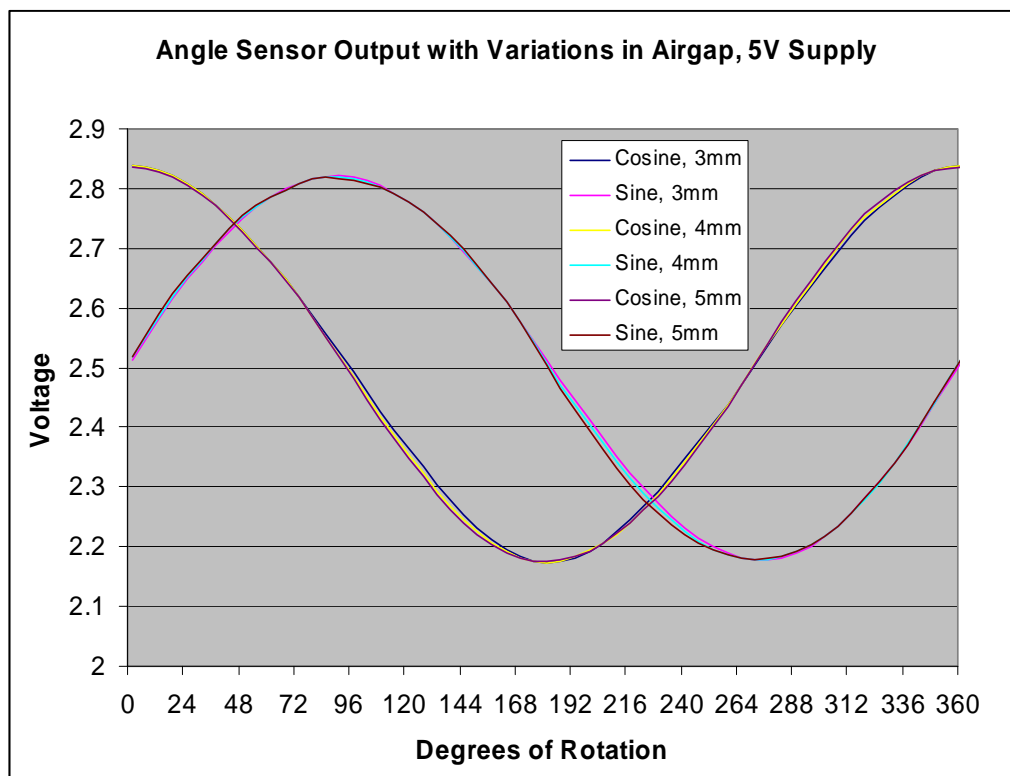

Functional Block Diagram, Marking, and Pinout

The AAT001-10E package is marked “FCVe.” The device contains four sensing resistors with the pinned layer 90 degrees apart. The resistors are connected as two half-bridges, providing sine and cosine outputs:

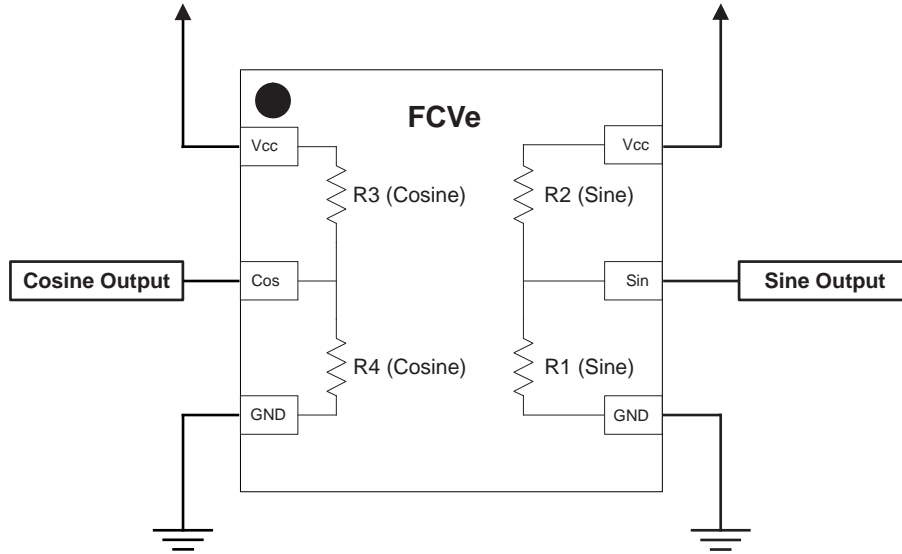

Operating Specifications

Parameter	Test Condition	Min.	Typ.	Max.	Units
Resistance (Each Resistor) ⁶	25°C	0.6	1.25	2.5	MΩ
Peak-to-Peak Signal Level	Operating at 25°C	130	160	180	mV/V
Required Applied Magnetic Field Strength	Operating	30		200	Oe ²
Angular Measurement Error, Variable Bias ³	Operating			3	Angular Degrees
Angular Measurement Error, Fixed Bias ⁴	Operating			0.5	Angular Degrees
Supply Voltage	Operating			5.5	V
Offset Voltage	Operating at 25°C	-10		10	mV/V
Temperature Range of Operation	Operating	-40		125	°C
Temperature Coefficient of Resistance	Operating		+0.09		%/°C
TCOV ⁵	Operating		-0.13		%/°C

Absolute Maximum Ratings

Parameter	Min.	Typ.	Max.	Units
Supply Voltage			7	Volts
Storage Temperature	-40		170	°C
ESD (Human Body Model)			2,000	Volts
Applied Magnetic Field ¹			Unlimited	Oe

Notes:

1. Large magnetic fields CANNOT damage NVE sensors.
2. 1 Oe (Oersted) = 1 Gauss in air = 0.1 millitesla = 79.8 A/m.
3. Variable Bias means the magnetic field strength at the sensor can vary across the specification range; this is the same as a variable airgap between the bias magnet and the sensor.
4. Fixed Bias means the magnetic field strength at the sensor is constant; this is the same as a fixed airgap between the bias magnet and the sensor.
5. TCOV is the percent change in voltage signal over temperature with a constant supply voltage.
6. Resistance is specified with the saturating magnetic field applied.

Package Drawing – TDFN6 2.5 mm x 2.5 mm

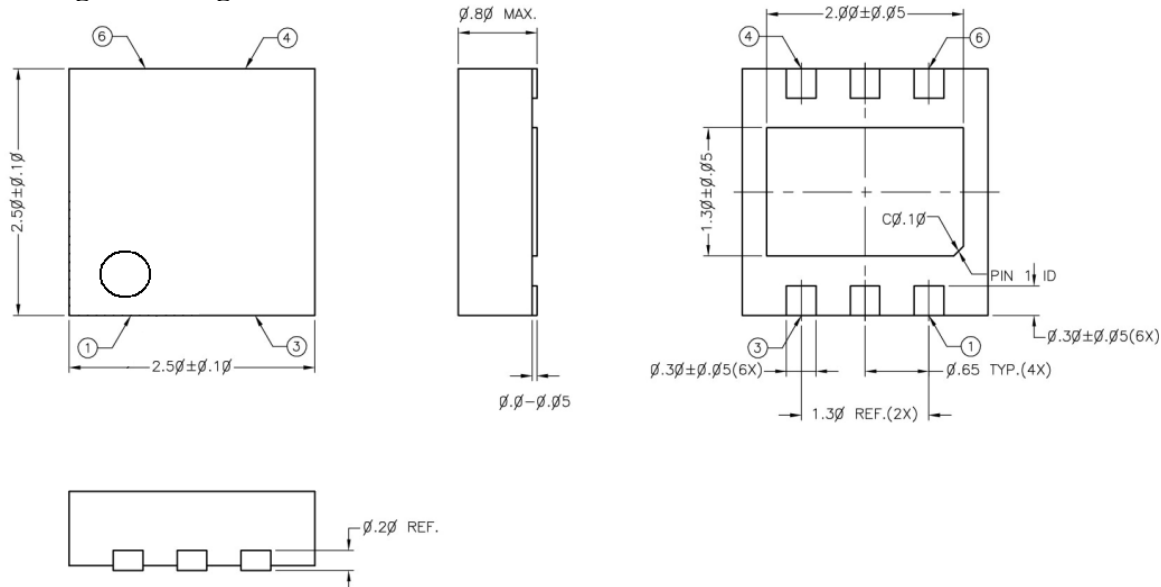

Notes:

- Dimensions in mm.
- The center pad may be left floating or connected to ground.



HY-LINE[®]
S E N S O R - T E C

Inselkammerstr. 10
82008 Unterhaching
Tel.: 089/614 503 - 30

E-Mail: sensortec@hy-line.de

Postfach 1222
82002 Unterhaching
Fax: 089/614 503 - 34
www.hy-line.de

The information provided by NVE Corporation is believed to be accurate. However, no responsibility is assumed by NVE Corporation for its use, nor for any infringement of patents, nor rights or licenses granted to third parties, which may result from its use. No license is granted by implication, or otherwise, under any patent or patent rights of NVE Corporation. NVE Corporation does not authorize, nor warrant, this product for use in life support devices or systems or other critical applications.

Specifications are subject to change without notice.

SB-00-024; September 21, 2009