

AHLxxx-14E Nanopower Digital Switch

Key Features

- Low Voltage Operation to 0.9 V
- Extremely Low Power Consumption
- Digital Switch Output
- Precise Detection of Low Magnetic Fields
- Ultraminiature Package

Description

The AHLxxx-14E series sensors are Giant Magnetoresistive (GMR) Digital Switch devices designed to run at low voltages and extremely low currents. The devices are manufactured with NVE's patented spintronic GMR technology for unmatched miniaturization, sensitivity, precision, and low power.

The output is configured as a magnetic "switch" where the output turns on when the magnetic field is applied, and turns off when the field is removed. The IC is available for continuous duty operation, or internally duty cycled at approximately 0.1% to conserve power. An integrated latch ensures the output is available continuously in duty-cycled mode. The part is available in NVE's new ULLGA leadless package measuring just 1.1 mm x 1.1 mm x 0.4 mm.

The AHLxxx-14E parts are ideal for battery-powered devices such as gas and water meters, portable instruments, or any place where an extremely low power device is required. The applied magnetic field can be of either polarity, and in the duty-cycled operating mode the part consumes less than 1 microwatt. The magnetic operate point is extremely stable over supply voltage and temperature variations. The output is current-sinking, and can sink up to 100 microamps.

The product consists of an approximately 0.6 mm x 0.6 mm die containing a GMR sensor element, CMOS signal processing circuitry to convert the analog sensor element output to a digital output, and an oscillator and timing circuit for duty cycling. The plastic package is ultra-small, ultra-low profile, surface mount, lead-free, and RoHS compliant. Bare die are also available for extremely space-critical applications.

Versions of this part with different magnetic characteristics are available. Please contact NVE for details.

HY-LINE[®]
S E N S O R - T E C

Inselkammerstr. 10
82008 Unterhaching
Tel.: 089/614 503 - 30

E-Mail: sensortec@hy-line.de

Postfach 1222
82002 Unterhaching
Fax: 089/614 503 - 34
www.hy-line.de

Functional Block Diagram

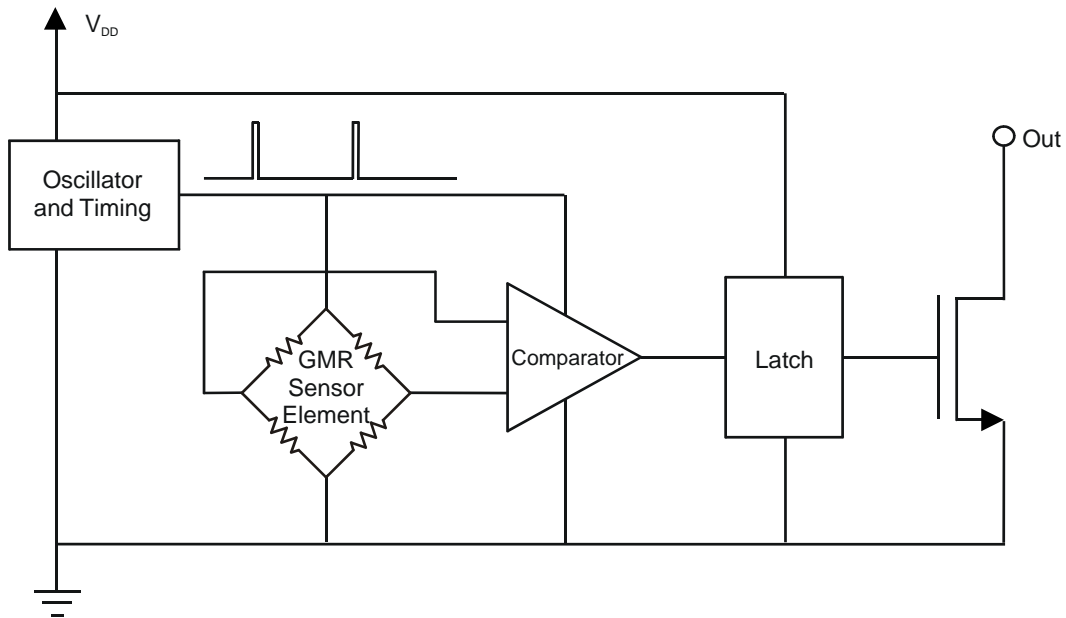

Operation

The direction of magnetic field sensitivity is planar to the package. As the field varies in intensity, the digital output will turn on and off. The user must provide a pull-up resistor on the output terminal.

Sensor Activation With a Permanent Magnet

The diagrams below show two permanent magnet orientations that will activate the sensor in the direction of sensitivity (planar to the package):

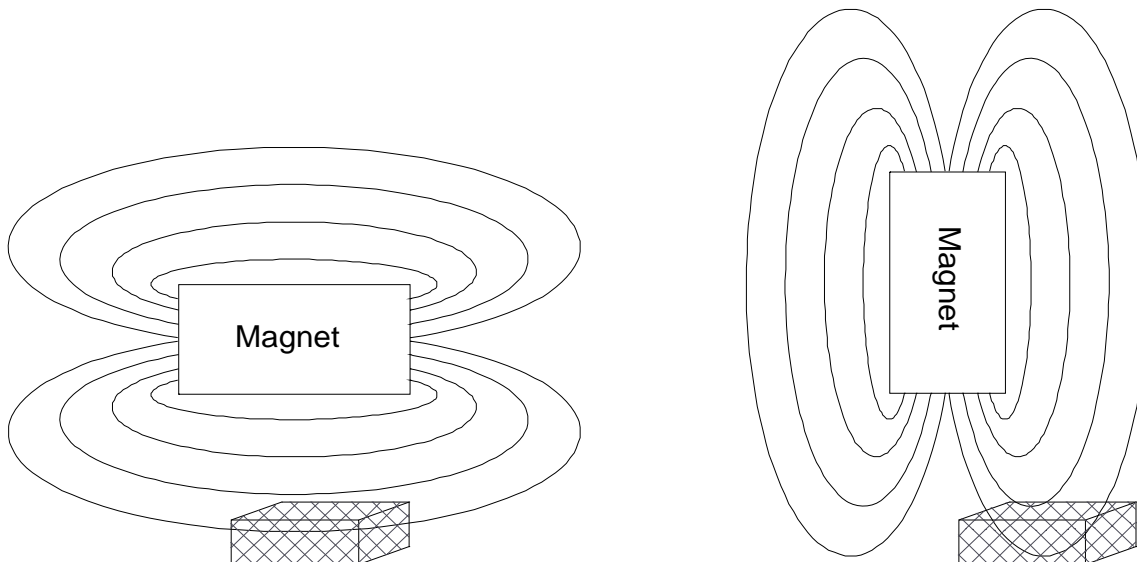

Electrical and Magnetic Specifications

(specifications valid over all operating voltage and temperature ranges):

Parameter	Min.	Typ.	Max.	Units
Magnetic Operate Point (AHLx21-14E)	15	20	25	Oersteds ⁽¹⁾
Magnetic Operate Point (AHLx24-14E)	21	28	34	Oersteds ⁽¹⁾
Magnetic Operate Point (AHLx25-14E)	7	10	13	Oersteds ⁽¹⁾
Magnetic Operate Point (AHLx26-14E)	5	7.5	10	Oersteds ⁽¹⁾
Magnetic Release Point	3.5			Oersteds ⁽¹⁾
Hysteresis	0.5		12	Oersteds ⁽¹⁾
Operating Voltage (V _{DD})	0.9	1.25	2.4	Volts
Quiescent Current at 0.9 V (AHL0xx-14E)		0.032	0.050	μA
Quiescent Current at 0.9 V (AHL9xx-14E)		20	35	μA
Quiescent Current at 1.4 V (AHL0xx-14E)		0.095	0.150	μA
Quiescent Current at 1.4 V (AHL9xx-14E)		35	55	μA
Quiescent Current at 2.4 V (AHL0xx-14E)		0.420	0.650	μA
Quiescent Current at 2.4 V (AHL9xx-14E)		75	110	μA
Peak Current During Sensor Sampling (AHL0xx-14E, 1.4 V)		35	55	μA
Output Drive Current	100			μA
V _{OL} at 100 μA Output Drive Current (V _{DD} = 1.25 V)			0.20	Volts
Output Leakage Current			0.005	μA
Frequency Response at 1.4V (AHL0xx-14E)		110	160	Hz
Frequency Response (AHL9xx-14E)		100K		Hz
Temperature Range of Operation	-40		85	°C

Absolute Maximum Ratings

Parameter	Rating	Units
Applied Magnetic Field	Unlimited ⁽²⁾	Oersteds
Supply Voltage	5.5	Volts
Output Off Voltage	5.5	Volts
Output Current	200	μA
Maximum Junction Temperature	+170	°C
Storage Temperature	-65 to +170	°C

Notes:

- 1 Oe (Oersted) = 1 Gauss in air = 0.1 mT
- 2 Large magnetic fields WILL NOT damage NVE GMR sensors

Performance Over Power Supply Range:

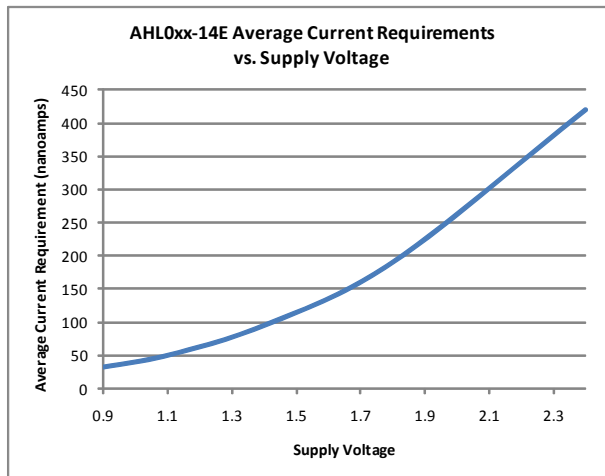
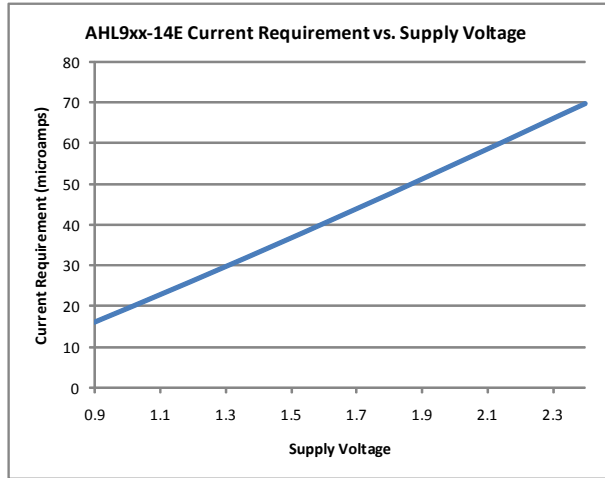

HY-LINE[®]
S E N S O R - T E C

Inselkammerstr. 10
82008 Unterhaching
Tel.: 089/614 503-30
E-Mail: sensortec@hy-line.de

Postfach 1222
82002 Unterhaching
Fax: 089/614 503-34
www.hy-line.de

Package Drawings, Dimensions, and Specifications:

4-Lead ULLGA Package

1.1 mm x 1.1 mm x 0.40 mm; Lead Pitch 0.65 mm

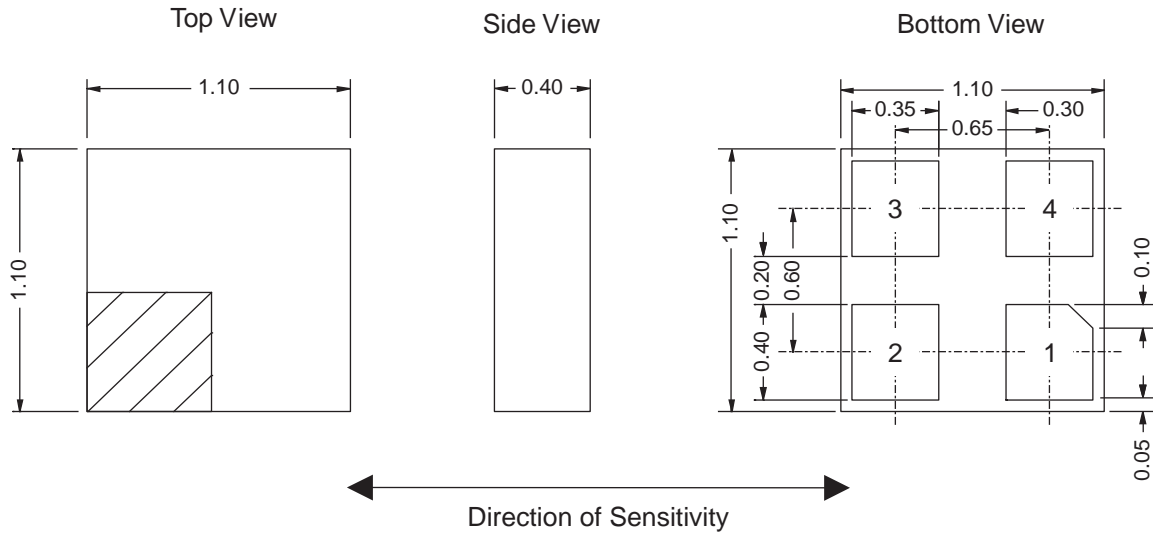

Dimensions in mm; package thickness ± 0.05 mm; all other dimensions ± 0.10 mm.

Pinout:

Pin 1	No Connect
Pin 2	V _{DD}
Pin 3	Out
Pin 4	Ground

The information provided by NVE Corporation is believed to be accurate. However, no responsibility is assumed by NVE Corporation for its use, nor for any infringement of patents, nor rights or licenses granted to third parties, which may result from its use. No license is granted by implication, or otherwise, under any patent or patent rights of NVE Corporation. NVE Corporation does not authorize, nor warrant, this product for use in life support devices or systems or other critical applications without the express written approval of the President of NVE Corporation.

Specifications are subject to change without notice.

SB-00-027; rev. December 9, 2009