

# TFT-DISPLAY DATASHEET

## DATA IMAGE

Model: FG04032PDUSWVG01

### BRIEF SPEC.:

Main Feature	Landscape Wide Viewing Angle Wide Aspect Ratio
Active Screen Area	95.04 x 53.86 (mm)
Diagonal   Format	4.3 "   16:9
Resolution	480 X 272
Colors	8 Bit
Backlight	White
Brightness	570 cd/m <sup>2</sup>
LED Life Time	30K (h)
Interface	TTL
Viewing Angle	80/80 L/R 80/80
Touchscreen	no
Power Supply	3.3,V (Typ.)
Module Outline	105.5 x 67.2 x 3.1 (mm)
Operation Temperature	-20... +70 °C
Storage Temperature	-30... +80 °C
Surface Treatment	Antiglare



# DATA IMAGE CORPORATION

## TFT Module Specification

Preliminary

ITEM NO.: FG04032PDUSWMG01

### Table of Contents

1. COVER & CONTENTS .....	1
2. RECORD OF REVISION .....	2
3. FEATURE .....	3
4. GENERAL SPECIFICATIONS .....	3
5. ELECTRICAL CHARACTERISTICS .....	3
6. BLOCK DIAGRAM .....	4
7. PIN CONNECTIONS .....	5
8. AC CHARACTERISTICS .....	6
9. OPTICAL CHARACTERISTIC .....	11
10. QUALITY ASSURANCE .....	13
11. LCM PRODUCT LABEL DEFINE.....	17
12. PRECAUTIONS IN USE LCM .....	19
13. OUTLINE DRAWING .....	20
14. PACKAGE INFORMATION .....	21

Customer Companies	R&D Dept.	Q.C. Dept.	Eng. Dept.	Prod. Dept.
	ALEX	PRETTY	DAVID	KEN
Approved by	Version:	Issued Date:	Sheet Code:	Total Pages:
	3	27/JUL/15'		21



### 3. FEATURE

- 64 gray level with 2 bit dithering function to realize 16M colors

### 4. GENERAL SPECIFICATIONS

Parameter	Specifications	Unit
Display resolution	480X R.G.B x 272	dot
LCD Active area	95.04(W) x 53.86(H)	mm
Screen size	4.3(Diagonal)	inch
pixel pitch	0.198 (W) x 0.198(H)	mm
Color configuration	R.G.B. Stripe	
Overall dimension	105.5 (W) x 67.2(H) x 3.1(D)	mm
Weight	TBD	g
Surface treatment	Anti-Glare	
View Angle direction(Gray inversion)	ALL	
Our components and processes are compliant to RoHS standard		

### 5. ELECTRICAL CHARACTERISTICS

GND=0V, Ta=25°C

Parameter	Symbol	MIN.	Typ.	MAX.	Unit	Remark
Power Supply voltage	V <sub>DD</sub>	3.0	3.3	3.6	V	Note1
Power Supply Current	I <sub>DD</sub>	--	17	20	mA	V <sub>DD</sub> =3.3V
Ripple Voltage	V <sub>RPVDD</sub>	--	--	100	mVp-p	
"H" level logical input voltage	V <sub>IH</sub>	0.8VDD	--	VDD	V	
"L" level logical input voltage	V <sub>IL</sub>	0	--	0.2VDD	V	
Operating temperature	Topa	-20	--	70	°C	Ambient temperature
Storage temperature	Tstg	-30	--	80	°C	Ambient temperature

Note1:VDD Absolute Maximum Ratings -0.3V~+6V

#### 5.1 Backlight driving for power conditions

Ta= 25 °C

Parameter	Symbol	Min.	Typ.	Max.	Unit	Remark
LED current	I <sub>L</sub>	--	20	--	mA	
LED voltage	V <sub>L</sub>		33		V	
LED life time		--	30000	--	Hours	Note 1



Voltage : VLED= 33V(Typ.)

Current : 20mA

**6. BLOCK DIAGRAM**

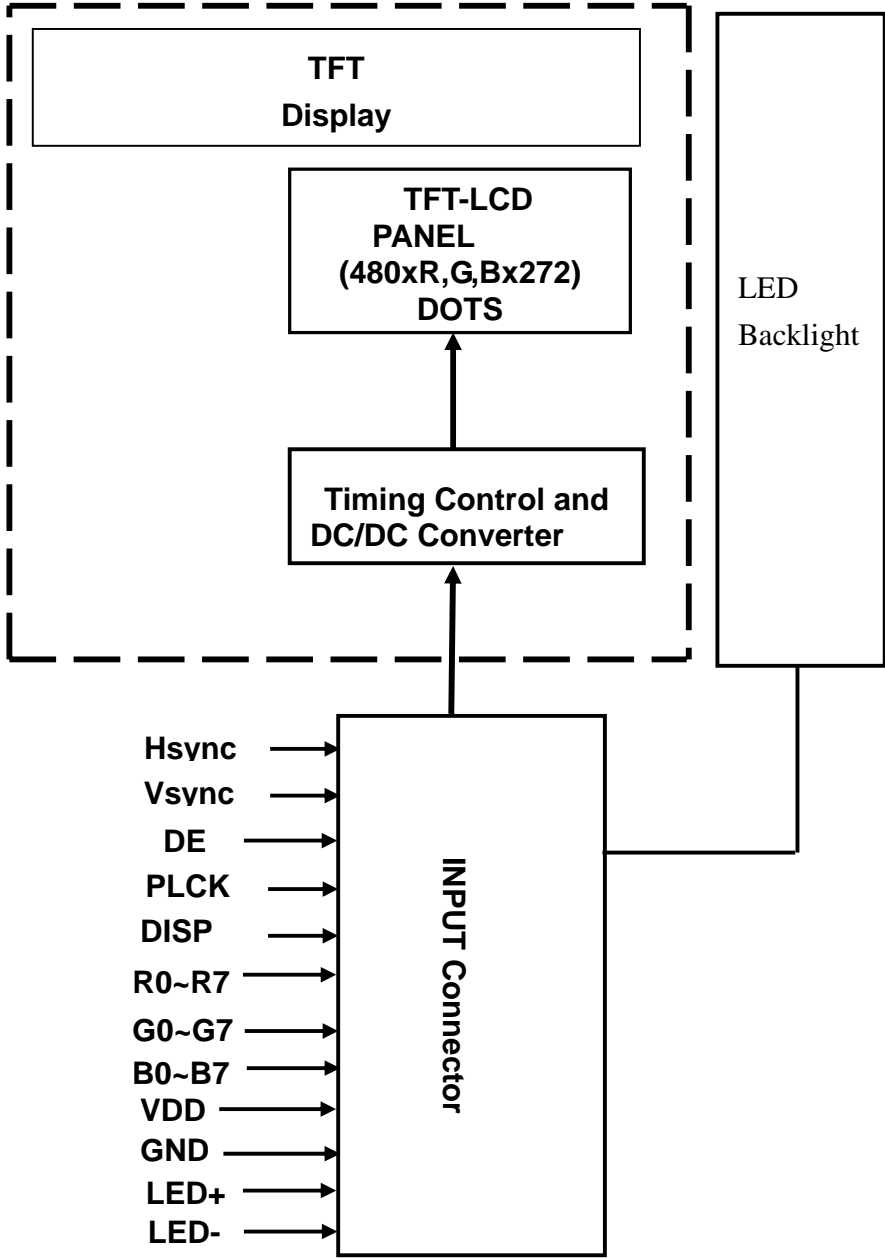

## 7. PIN CONNECTIONS

### 7.1 Input Pins Connection

Pin No	Symbol	Function	Remark
1	LED+	LED Power Source input terminal (Anode side)	
2	LED-	LED Power Source input terminal (Cathode side)	
3	VDD	Power Supply : +3.3V	
4	VDD	Power Supply : +3.3V	
5	R0	Digital data input. R0 is LSB and R7 is MSB	
6	R1		
7	R2		
8	R3		
9	R4		
10	R5		
11	R6		
12	R7		
13	GND	Ground	
14	G0	Digital data input. G0 is LSB and G7 is MSB	
15	G1		
16	G2		
17	G3		
18	G4		
19	G5		
20	G6		
21	G7		
22	GND	Ground	
23	B0	Digital data input. B0 is LSB and B7 is MSB	
24	B1		
25	B2		
26	B3		
27	B4		
28	B5		
29	B6		
30	B7		
31	GND	Ground	
32	PLCK	clock signal to sample each data	
33	DISP	Display ON/OFF Control ON=H(VDD), OFF=L(GND)	
34	Hsync	Horizontal synchronous signal	
35	Vsync	Vertical synchronous signal	
36	DE	Data enable	
37	NC	No Connection	
38	NC	No Connection	
39	NC	No Connection	
40	NC	No Connection	

## 8. AC CHARACTERISTICS

### 8.1 Input Timing Requirement

(480RGBx272, Ta=25°C, VDDIO=1.8V to 3.6V, GND= 0V)

Parameter	Symbol	MIN.	TYP.	MAX.	Unit
Clock cycle	f <sub>CLK(1)</sub>	-	9	15	MHz
Hsync cycle	1/th	-	17.14	-	KHz
Vsync cycle	1/tv	-	59.94	-	Hz
Horizontal Signal					
Horizontal cycle	th	525	525	605	CLK
Horizontal display period	thd	480	480	480	CLK
Horizontal front porch	thf	2	2	82	CLK
Horizontal pulse width	thp <sup>(2)</sup>	2	41	41	CLK
Horizontal back porch	thb <sup>(2)</sup>	2	2	41	CLK
Vertical Signal					
Vertical cycle	tv	285	286	511	H <sup>(1)</sup>
Vertical display period	tvd	272	272	272	H <sup>(1)</sup>
Vertical front porch	tvf	1	2	227	H <sup>(1)</sup>
Vertical pulse width	tvp <sup>(2)</sup>	1	10	11	H <sup>(1)</sup>
Vertical back porch	tvb <sup>(2)</sup>	1	2	11	H <sup>(1)</sup>

**Note:** (1) Unit: CLK=1/ f<sub>CLK</sub>, H=th,

(2) It is necessary to keep tvp+tvb=12 and thp+thb=43 in sync mode.

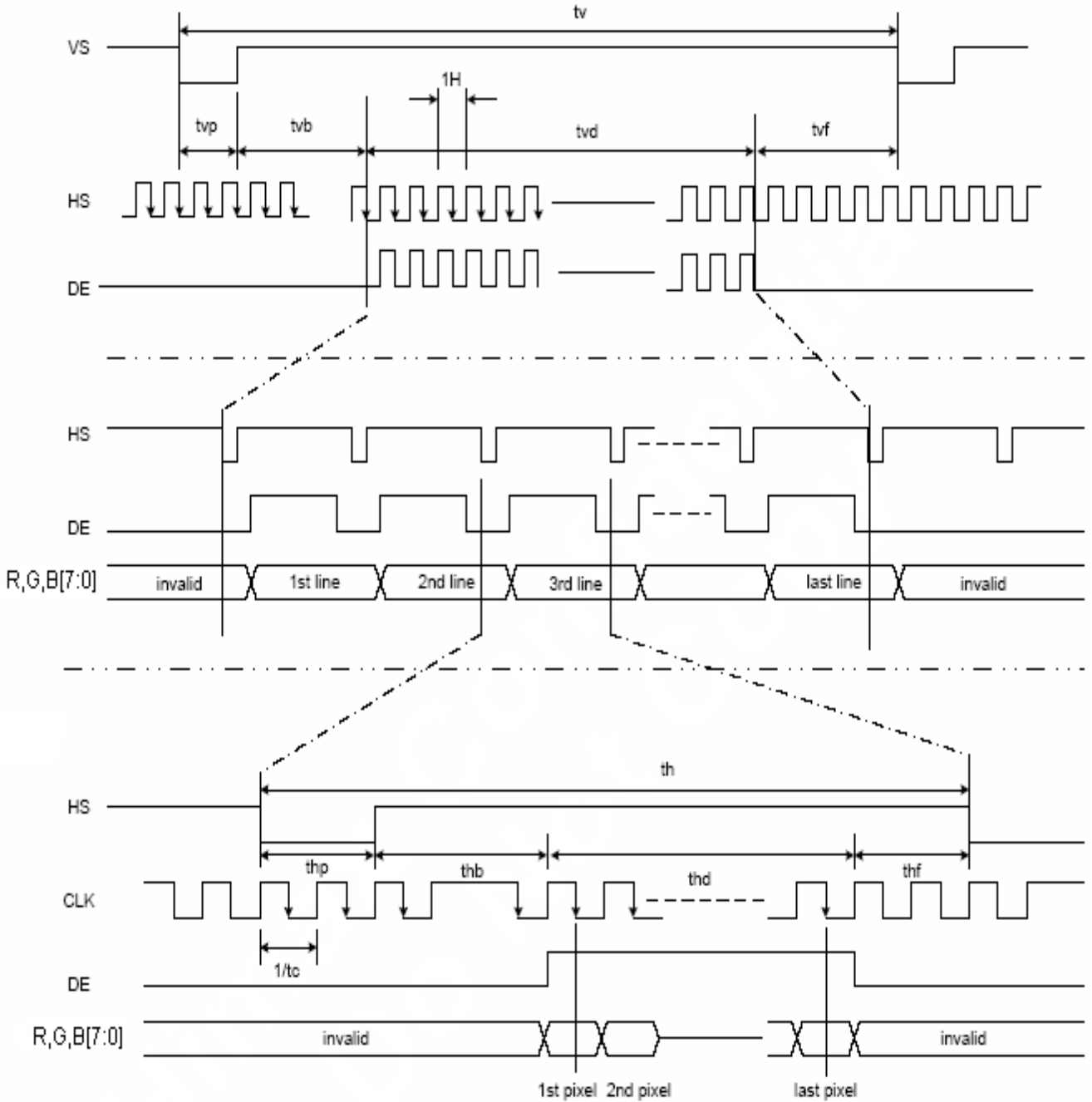

**Fig 1. Parallel RGB input timing**



**8.2 Input Setup Timing Requirement**

 (T<sub>A</sub>=25°C, VDDIO=1.8V to 3.6V, DVSS= 0V)

Parameter	Symbol	MIN.	TYP.	MAX.	Unit
DISP setup time	t <sub>diss</sub>	10	-	-	ns
DISP hold time	t <sub>dish</sub>	10	-	-	ns
Clock period	PW <sub>CLK(2)</sub>	66.7	-	-	ns
Clock pulse high period	PWH <sub>(2)</sub>	26.7	-	-	ns
Clock pulse low period	PWL <sub>(2)</sub>	26.7	-	-	ns
Hsync setup time	t <sub>hs</sub>	10	-	-	ns
Hsync hold time	t <sub>hh</sub>	10	-	-	ns
Data setup time	t <sub>ds</sub>	10	-	-	ns
Data hold time	t <sub>dh</sub>	10	-	-	ns
Vsync setup time	t <sub>vhs</sub>	10	-	-	ns
Vsync hold time	t <sub>vhh</sub>	10	-	-	ns

**Note:** (1) t<sub>r</sub>, t<sub>f</sub> is defined 10% to 90% of signal amplitude.

(2) For parallel interface, maximum clock frequency is 15MHz.

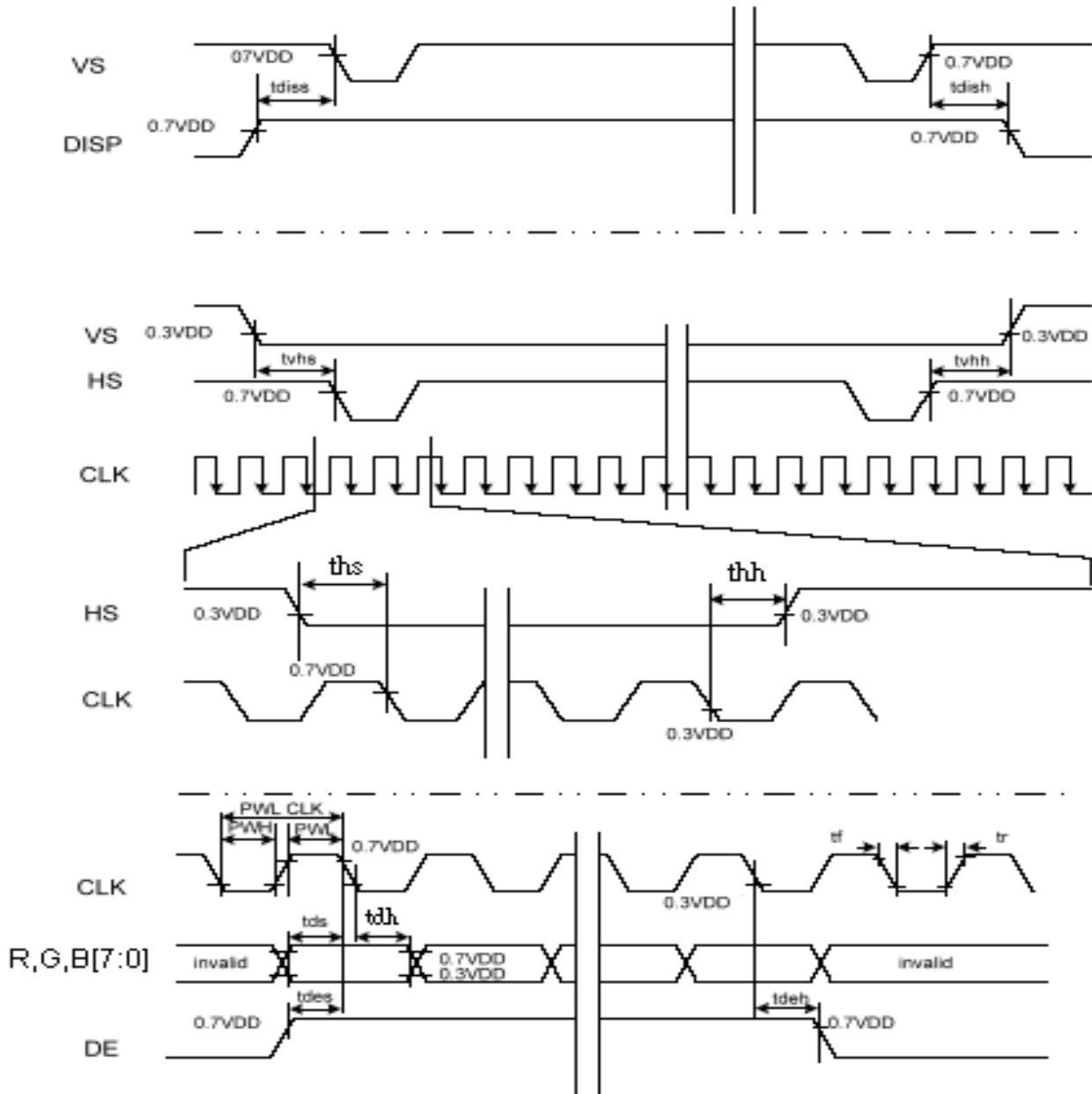
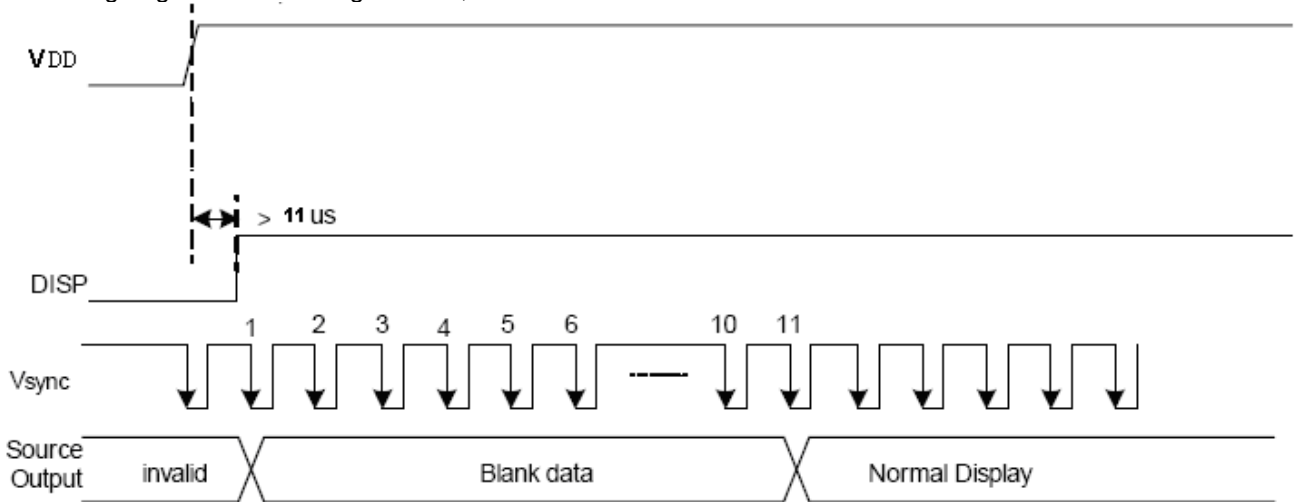

Fig 2. Input setup timing requirement

### 8.3 TCON Power ON/OFF Control

The TCON IC has a power ON/OFF sequence control function. When DISP pin is pulled "H", blank data is outputted for 10-frames first, from the falling edge of the following VSYNC signal. Similarly, when DISP is pulled "L", 10-frames of blank data will be outputted from the falling edge of the following VSYNC, too.



**Fig 3. Power On Sequence**

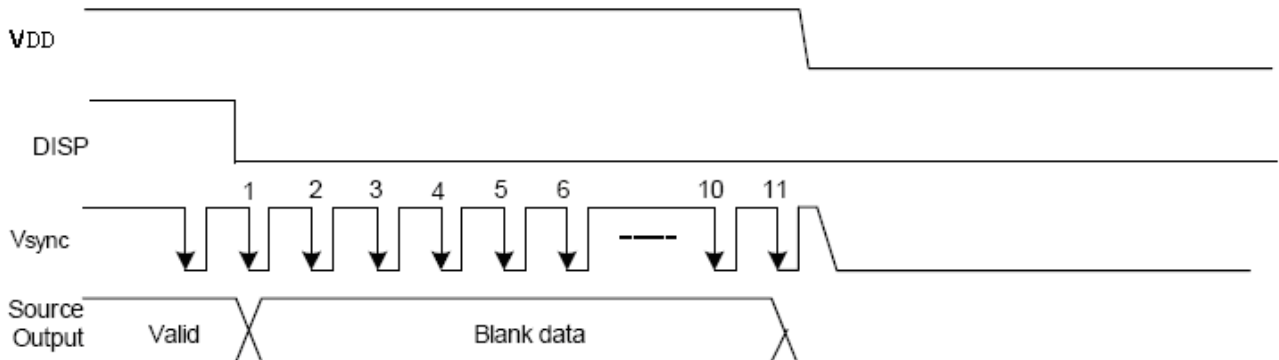

**Fig 4. Power Off Sequence**

**9. Optical Characteristics**

Item		Symbol	Condition	Min.	Typ.	Max.	Unit	Remark
Response time	Rise	Tr	$\theta=0^\circ$	--	5	10	ms	Note 4
	Fall	Tf		--	15	20	ms	
Contrast ratio		CR	At optimized viewing angle	200	300	--		Note 5
Viewing angle	Top		$CR \geq 10$	70	80	--	Deg.	Note 6
	Bottom			70	80	--		
	Left			70	80	--		
	Right			70	80	-		
Luminance			$\theta=0^\circ$	460	570	--	cd/m <sup>2</sup>	Note 7
Uniformity		B-uni		70	80		%	Note 8
White chromaticity		X	$\theta=0^\circ$	0.27	0.32	0.37		Note 7
		y		0.28	0.33	0.38		

Note 1: Ambient temperature =25°C.

Note 2: To be measured in the dark room.

Note 3: To be measured on the center area of panel with a viewing cone of 1° by Topcon luminance meter BM-7A, after 2 minutes operation.

Note 4: Definition of response time:

The output signals of photo-detector are measured when the input signals are changed from "white" to "black"(rising time) and from "black" to "white"(falling time), respectively. The response time is defined as the time interval between the 10% and 90% of amplitudes. Refer to figure as shown below.

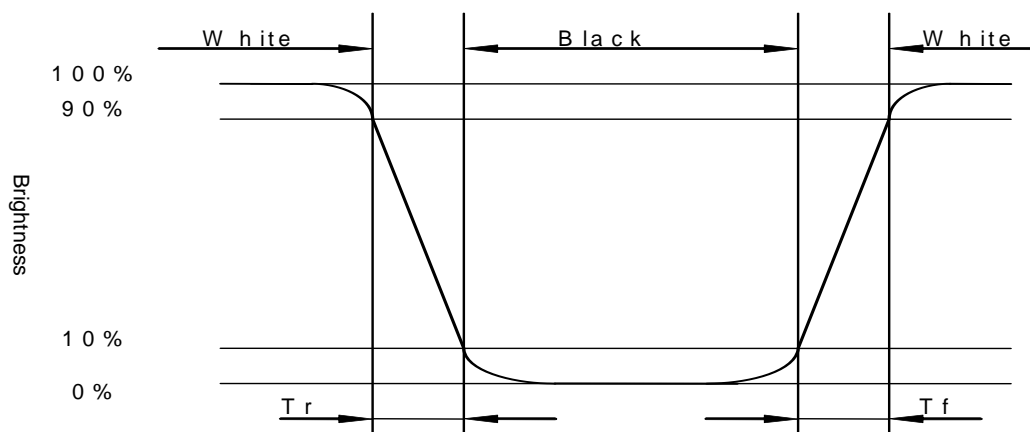

Note5: Definition of contrast ratio:

Contrast ratio is calculated with the following formula.

$$\text{Contrast ratio (CR)} = \frac{\text{Photo-detector output when LCD is at "White" state}}{\text{Photo-detector output when LCD is at "Black" state}}$$

Note 6. Definition of viewing angle:

Refer to figure as below.

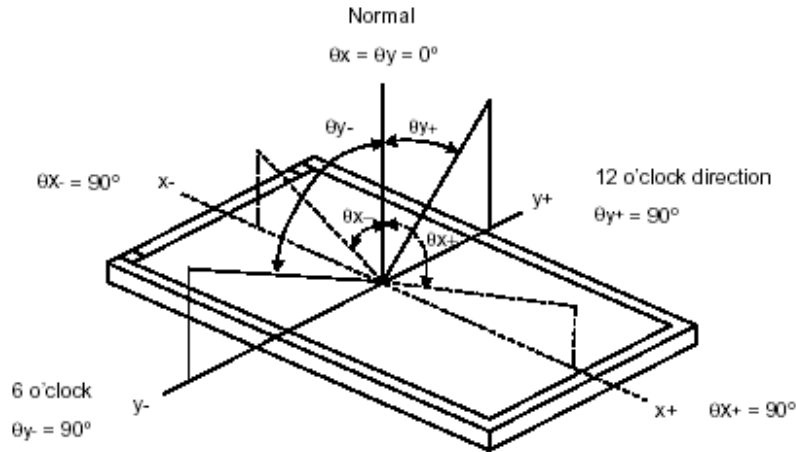

Note 7. Measured at the center area of the panel when all the input terminals of LCD panel are electrically opened.

Note 8: Definition of Brightness Uniformity (B-uni):

### Luminance Measuring Points

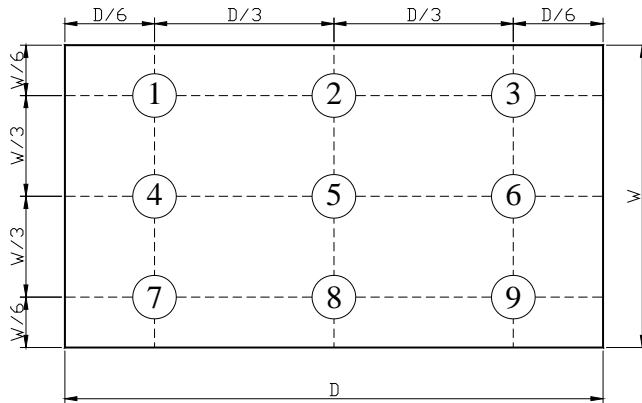

$$B\text{-uni} = \frac{\text{Minimum luminance of 9 points}}{\text{Maximum luminance of 9points}}$$

## 10. QUALITY ASSURANCE

### 10.1 RA Test Condition

#### 10.1.1 Temperature and Humidity(Ambient Temperature)

Temperature :  $25 \pm 5^{\circ}\text{C}$

Humidity :  $65 \pm 5\%$

#### 10.1.2 Operation

Unless specified otherwise, test will be conducted under function state.

#### 10.1.3 Container

Unless specified otherwise, vibration test will be conducted to the product itself without putting it in a container.

#### 10.1.4 Test Frequency

In case of related to deterioration such as shock test. It will be conducted only once.

#### 10.1.5 Test Method

No.	Reliability Test Item & Level	Test Level	Remark
1	High Temperature Storage Test	T=80°C,240hrs	IEC68-2-2
2	Low Temperature Storage Test	T=-30°C,240hrs	IEC68-2-1
3	High Temperature Operation Test	T=70°C,240hrs	IEC68-2-2
4	Low Temperature Operation Test	T=-20°C,240hrs	IEC68-2-1
5	High Temperature and High Humidity Operation Test	T=60°C,90% RH,240hrs	IEC68-2-3
6	Thermal Cycling Test	-30°C → +25°C → +80°C,200 Cycles 30 min 5min 30 min	IEC68-2-14
7	Vibration Test	Frequency:10~ 55 Hz Amplitude:1.5 mm Sweep Time:11min Test Period:6 Cycles for each Direction of X,Y,Z	IEC68-2-6
8	Drop Test	Height:60cm 1 conner,3edges,6surfaces	IEC68-2-32
9	Shock Test	100G,6ms,Direction: $\pm X \pm Y \pm Z$ Cycle:3times	IEC68-2-27
10	ESD Test	State: operating Location: LCM/TP surface Condition:150pf 330Ω Contact +/- 6kV Air +/-8kV Criteria: Class C	IEC61000-4-2

## 10.2 Inspection Judgment standard

### 10.2.1 Inspection conditions

10.2.1.1 Inspection Distance :  $35 \pm 5$  cm

10.2.1.2 View Angle : Inspection under test condition :  $\pm 5^\circ$

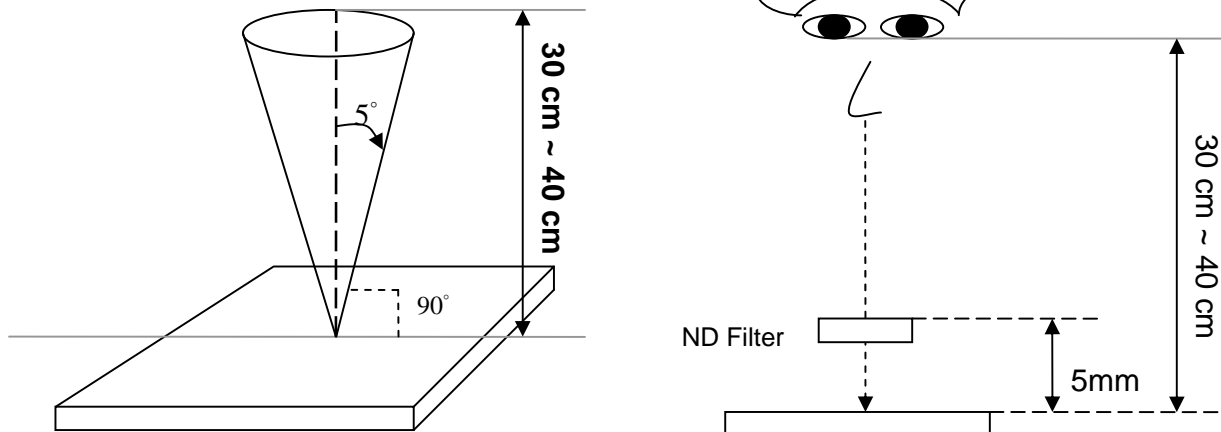

### 10.2.1.3 Environment conditions :

Ambient Temperature :		$25 \pm 5^\circ\text{C}$
Ambient Humidity :		$65 \pm 5\%$
Ambient Illumination	Cosmetic Inspection	More than 600lux
	Functional Inspection	300 ~ 800lux

**10.3 Inspection Condition**

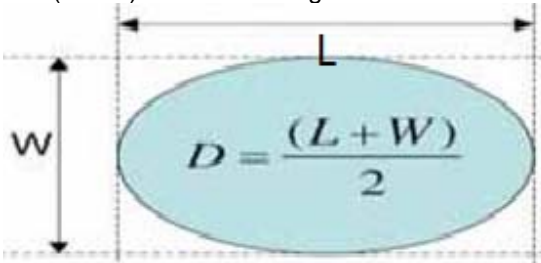
No.	Parameter	Criteria																		
1	Operating	Display function: No Display malfunction (Major)																		
		Contrast ratio (Black, White): Does not meet specified range in the spec. (Major) (Note:3)																		
		Line Defect: No obvious Vertical and Horizontal line defect in bright, dark and colored. (Major) (Note:1)																		
		Point Defect (Red, green, blue, dark): Active area $\leq 4$ dots (Minor)(Note:1)																		
		<table border="1"> <thead> <tr> <th>Item</th> <th>Acceptable number</th> <th>Total</th> <th>Class Of Defects</th> <th>AQL Level</th> </tr> </thead> <tbody> <tr> <td>Bright</td> <td>2</td> <td rowspan="2">4</td> <td rowspan="4">Minor</td> <td rowspan="4">1.5</td> </tr> <tr> <td>Dark</td> <td>3</td> </tr> <tr> <td>Adjacent Bright</td> <td>1</td> <td>1</td> </tr> <tr> <td>Adjacent Dark</td> <td>1</td> <td>1</td> </tr> </tbody> </table>	Item	Acceptable number	Total	Class Of Defects	AQL Level	Bright	2	4	Minor	1.5	Dark	3	Adjacent Bright	1	1	Adjacent Dark	1	1
		Item	Acceptable number	Total	Class Of Defects	AQL Level														
		Bright	2	4	Minor	1.5														
		Dark	3																	
		Adjacent Bright	1	1																
		Adjacent Dark	1	1																
Non-uniformity: Visible through 2%ND filter white, R, G, B and gray 50%pattern must be nil.(Minor)																				
Foreign material in Black or White spots shape ( $W > 1/4L$ ) (Note: 5)																				
<table border="1"> <thead> <tr> <th>Dimension</th> <th>Acceptable number</th> <th>Class Of Defects</th> <th>AQL Level</th> </tr> </thead> <tbody> <tr> <td><math>D \leq 0.3</math></td> <td>*</td> <td rowspan="3">Minor</td> <td rowspan="3">1.5</td> </tr> <tr> <td><math>0.3 &lt; D \leq 0.5</math></td> <td>3</td> </tr> <tr> <td><math>D &gt; 0.5</math></td> <td>0</td> </tr> </tbody> </table>	Dimension	Acceptable number	Class Of Defects	AQL Level	$D \leq 0.3$	*	Minor	1.5	$0.3 < D \leq 0.5$	3	$D > 0.5$	0								
Dimension	Acceptable number	Class Of Defects	AQL Level																	
$D \leq 0.3$	*	Minor	1.5																	
$0.3 < D \leq 0.5$	3																			
$D > 0.5$	0																			
$D = (L + W) / 2$ * : Disregard 																				
Foreign Material in Line or spiral shape ( $W \leq 1/4L$ ) (Note: 4)																				
<table border="1"> <thead> <tr> <th>Dimension</th> <th>Acceptable number</th> <th>Class Of Defects</th> <th>AQL Level</th> </tr> </thead> <tbody> <tr> <td><math>W &gt; 0.1\text{mm}, L &gt; 5\text{mm}</math></td> <td>0</td> <td rowspan="3">Minor</td> <td rowspan="3">1.5</td> </tr> <tr> <td><math>L \leq 5\text{mm}, 0.05\text{mm} &lt; W \leq 0.1\text{mm}</math></td> <td>3</td> </tr> <tr> <td><math>L \leq 5\text{mm}, W &lt; 0.05\text{mm}</math></td> <td>*</td> </tr> </tbody> </table>	Dimension	Acceptable number	Class Of Defects	AQL Level	$W > 0.1\text{mm}, L > 5\text{mm}$	0	Minor	1.5	$L \leq 5\text{mm}, 0.05\text{mm} < W \leq 0.1\text{mm}$	3	$L \leq 5\text{mm}, W < 0.05\text{mm}$	*								
Dimension	Acceptable number	Class Of Defects	AQL Level																	
$W > 0.1\text{mm}, L > 5\text{mm}$	0	Minor	1.5																	
$L \leq 5\text{mm}, 0.05\text{mm} < W \leq 0.1\text{mm}$	3																			
$L \leq 5\text{mm}, W < 0.05\text{mm}$	*																			
L : Length W : Width * : Disregard																				
2	External Inspection (non-operating)	Dimension: Outline (Major)																		
		Bezel appearance: uneven (Minor)																		



Scratch on the polarize & Touch Panel: (Note:2)			
Dimension	Acceptable number	Class Of Defects	AQL Level
$W > 0.1\text{mm}, L > 5\text{mm}$	0	Minor	1.5
$L \leq 5\text{mm}, 0.05\text{mm} < W \leq 0.1\text{mm}$	3		
$L \leq 5\text{mm}, W < 0.05\text{mm}$	*		
L : Length    W : Width    * : Disregard			
Dent and spots shape on the polarize (Note:2): (Note: 5)			
Dimension	Acceptable number	Class Of Defects	AQL Level
$D \leq 0.3$	*	Minor	1.5
$0.3 < D \leq 0.5$	3		
$D > 0.5$	0		
$D = (\text{Long} + \text{Short}) / 2$ * : Disregard			

Class of defects			<b>Definition</b>
	<b>Major</b>	AQL 0.65	It is a defect that is likely to result in failure or to reduce materially the usability of the product for the intended function.
<b>Minor</b>	AQL 0.65	It is a defect that will not result in functioning problem with deviation classified.	

Note:1.(a)Bright point defect is defined as point defect of R,G,B with area  $>1/2$  pixel respectively

(b)Dark point defect is defined as visible in full white pattern.

(c)The point defect must under 2% ND Filter visible .

Note:2 The external inspection should be conducted at the distance  $30 \pm 5\text{cm}$  between the eyes of inspector and the panel .

Note:3 Luminance measurement for contrast ratio is at the distance  $50 \pm 5\text{cm}$  between the detective head and the panel with ambient illuminance less than 1 lux. Contrast ratio is obtained at optimum view angle.

Note:4 W-Width in mm , L-length of Max.(L1,L2) in mm.

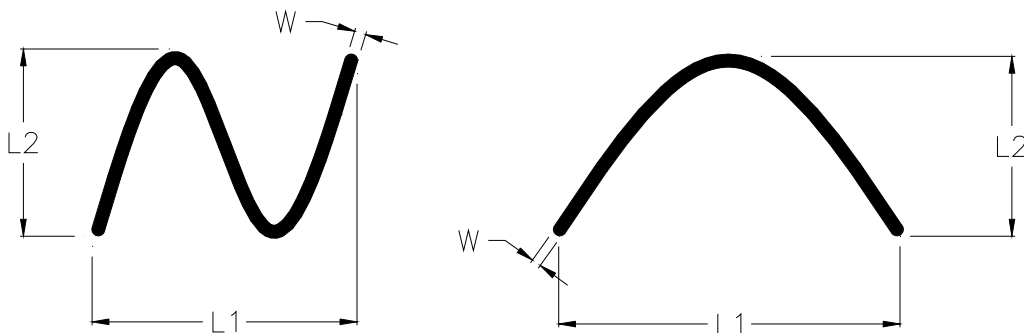

#### 10.4 Sampling Condition

Unless otherwise agree in written, the sampling inspection shall be applied to the incoming inspection of customer.

Lot size: Quantity of shipment lot per model.

Sampling type: normal inspection, single sampling

Sampling table: ISO 2859

Inspection level: Level II

## 11. LCM PRODUCT LABEL DEFINE

**Product Label style:**

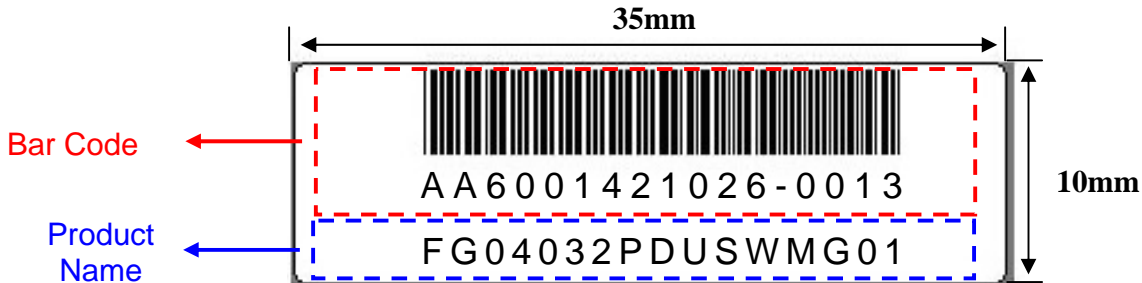

**BarCode Define:**

**A A 6 0014 2 10 26-0013**

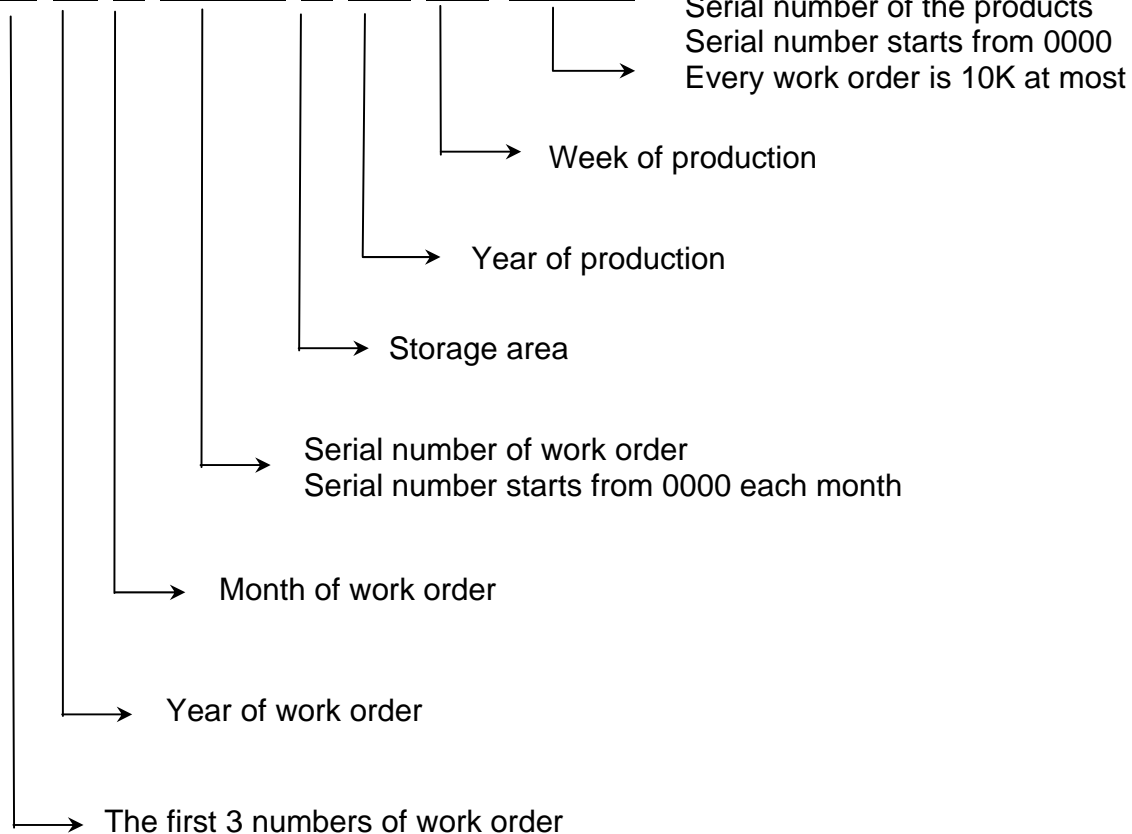

**Product Name Define:**

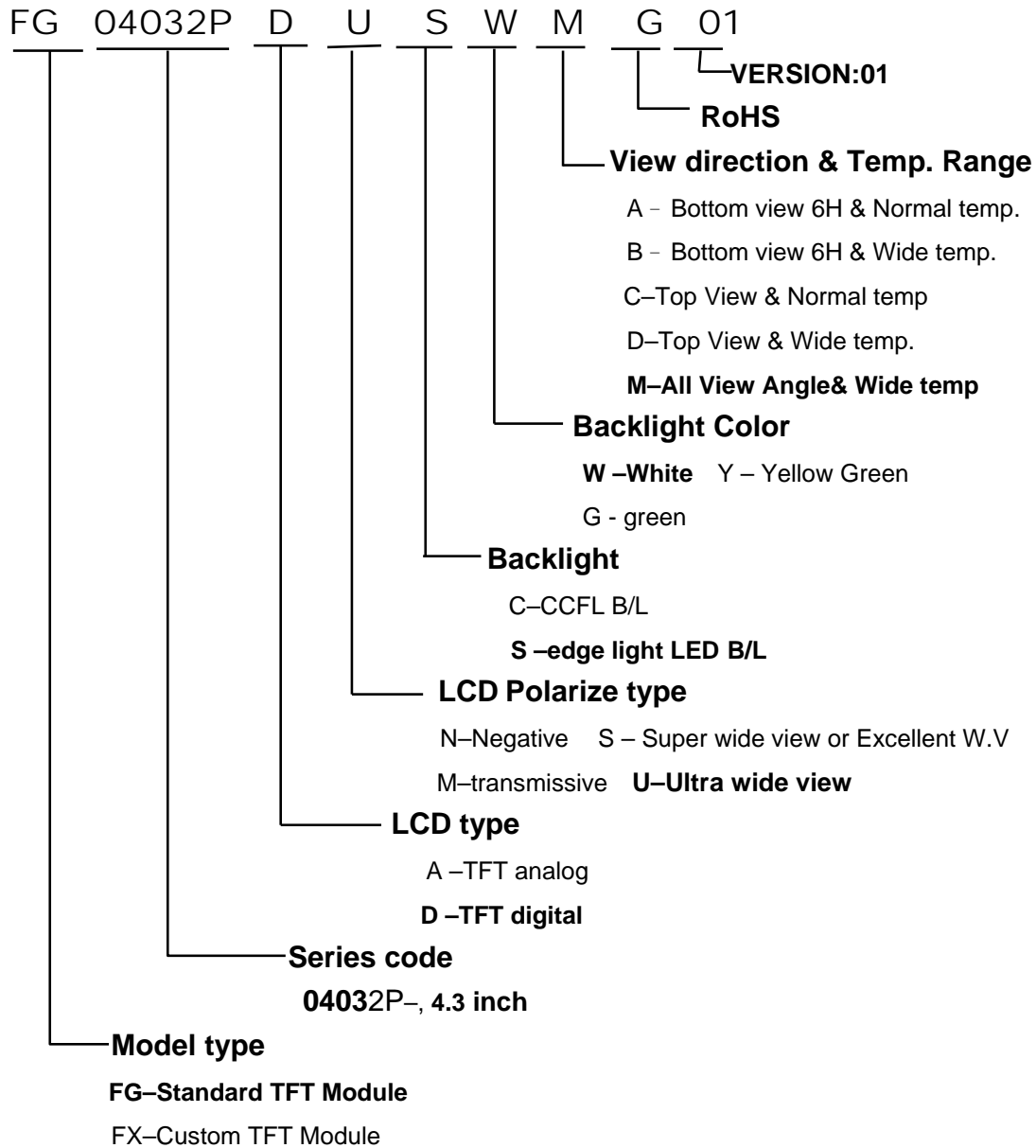

## 12. PRECAUTION FOR USING LCM

### 1. ASSEMBLY PRECAUTIONS

- (1) You must mount a module using holes arranged in four corners or four sides.
- (2) You should consider the mounting structure so that uneven force (ex. Twisted stress) is not applied to the module. And the case on which a module is mounted should have sufficient strength so that external force is not transmitted directly to the module.
- (3) Do not touch, push or rub the exposed polarizers with glass, tweezers or anything harder than HB pencil lead. And please do not rub with dust clothes with chemical treatment.
- (4) Wipe off saliva or water drops as soon as possible. Their long time contact with polarizer causes deformations and color fading.
- (5) Do not open the case because inside circuits do not have sufficient strength.
- (6) Please do not take a LCD module to pieces and reconstruct it. Resolving and reconstructing modules may cause them not to work well.
- (7) Please do not touch metal frames with bare hands and soiled gloves. A color change of the metal frames can happen during a long preservation of soiled LCD modules.
- (8) Please pay attention to handling lead wire of backlight so that it is not tugged in connecting with inverter.

### 2. OPERATING PRECAUTIONS

- (1) Please be sure to turn off the power supply before connecting and disconnecting signal input cable.
- (2) Please do not change variable resistance settings in LCD module. They are adjusted to the most suitable value. If they are changed, it might happen LCD does not satisfy the characteristics specification
- (3) Be careful for condensation at sudden temperature change. Condensation makes damage to polarizer or electrical contacted parts. And after fading condensation, smear or spot will occur.
- (4) When fixed patterns are displayed for a long time, remnant image is likely to occur.
- (5) Module has high frequency circuits. Sufficient suppression to the electromagnetic interference shall be done by system manufacturers. Grounding and shielding methods may be important to minimize the interference.
- (6) Please consider that LCD backlight takes longer time to become stable of radiation characteristics in low temperature than in room temperature.

### 3. ELECTROSTATIC DISCHARGE CONTROL

- (1) The operator should be grounded whenever he/she comes into contact with the module. Never touch any of the conductive parts such the copper leads on the PCB and the interface terminals with any

parts of the human body.

- (1) The modules should be kept in antistatic bags or other containers resistant to static for storage.
- (2) Only properly grounded soldering irons should be used.
- (3) If an electric screwdriver is used, it should be well grounded and shielded from commutator sparks.
- (4) The normal static prevention measures should be observed for work clothes and working benches; for the latter conductive (rubber) mat is recommended
- (5) Since dry air is inductive to statics, a relative humidity of 50-60% is recommended.

### 4. STORAGE PRECAUTIONS

- (1) When you store LCDs for a long time, it is recommended to keep the temperature between 0°C-40°C without the exposure of sunlight and to keep the humidity less than 90%RH.
- (2) Please do not leave the LCDs in the environment of high humidity and high temperature such as 60°C 90%RH
- (3) Please do not leave the LCDs in the environment of low temperature; below -20°C.

### 5. OTHERS

- (1) A strong incident light into LCD panel might cause display characteristics' changing inferior because of polarizer film, color filter, and other materials becoming inferior. Please do not expose LCD module direct sunlight and strong UV rays
- (2) Please pay attention to a panel side of LCD module not to contact with other materials in preserving it alone.
- (3) For the packaging box, please pay attention to the followings:
- (4) Please do not pile them up more than 5 boxes. (They are not designed so.) And please do not turn over.
- (5) Please handle packaging box with care not to give them sudden shock and vibrations. And also please do not throw them up.
- (6) Packing box and inner case for LCDs are made of cardboard. So please pay attention not to get them wet. (Such like keeping them in high humidity or wet place can occur getting them wet.)

### 6. LIMITED WARRANTY

Unless otherwise agreed between DATA IMAGE and customer, DATA IMAGE will replace or repair any of its LCD and LCM which is found to be defective electrically and visually when inspected in accordance with DATA IMAGE acceptance standards, for a period on one year from date of shipment. Confirmation of such date shall be based on freight documents. The warranty liability of DATA IMAGE is limited to repair and/or replacement on the terms set forth above. DATA IMAGE will not responsible for any subsequent or consequential events.

Confidential Document  
**13. OUTLINE DRAWING**

**PRELIMINARY**

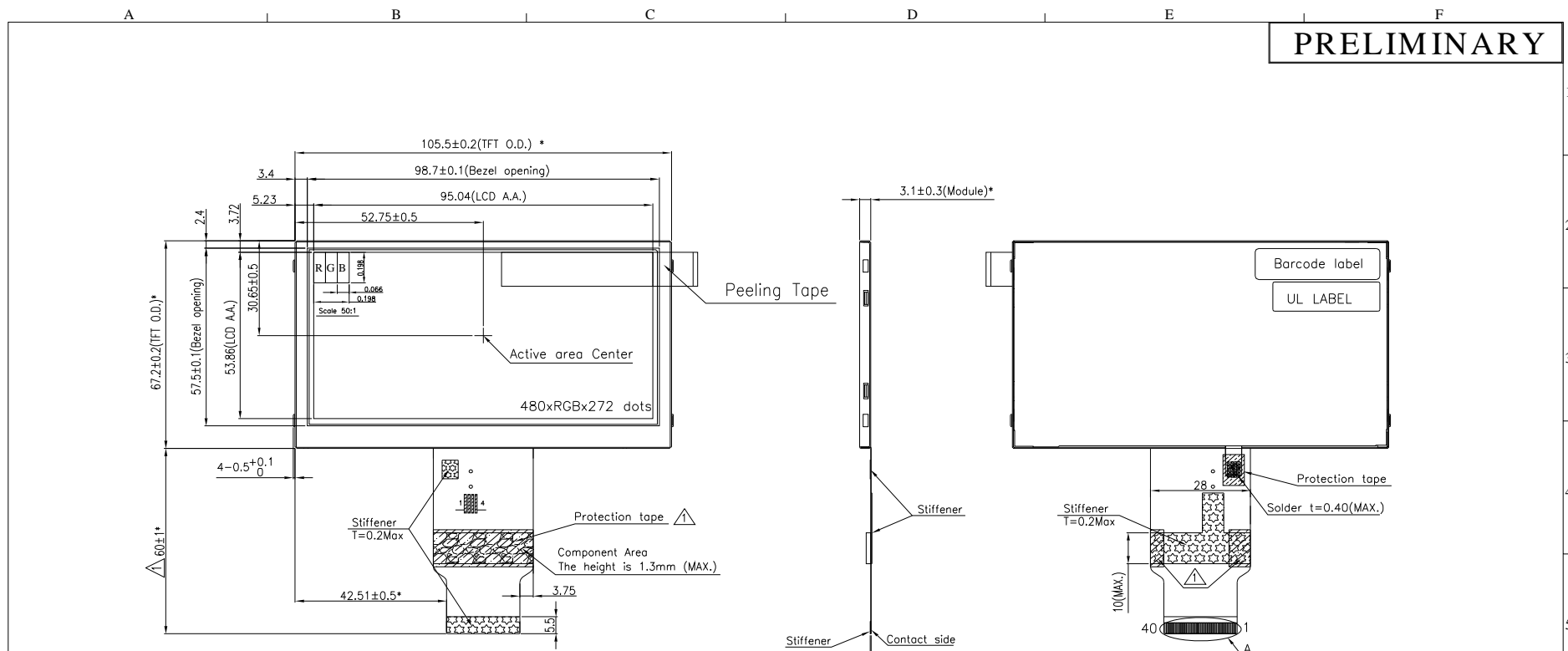

- Note:
- Luminance : 570cd/m<sup>2</sup>(Typ.) 460cd/m<sup>2</sup>(Min).
  - Uniformity : 70%
  - LCD FPC Match Connector: Molex 54132-4062 or equivalent.
  - Tolerance is ±0.3 unless otherwise noted.
  - The bending radius of FPC should be larger than 0.6mm.
  - For RoHS .
  - \* is important dimension.
  - Sunglass readable.
  - Surface treatment : Anti-glare.

VLED+ ↑      ↓ VLED-  
 Voltage : VLED= 3.3V(Typ.)  
 Current : 20mA

LCD FPC FUNCTIONS					
1 LED+	11 R6	21 G7	31 GND		
2 LED-	12 R7	22 GND	32 PCLK		
3 VDD	13 GND	23 B0	33 DISP		
4 VDD	14 G0	24 B1	34 Hsync		
5 R0	15 G1	25 B2	35 Vsync		
6 R1	16 G2	26 B3	36 DE		
7 R2	17 G3	27 B4	37 NC		
8 R3	18 G4	28 B5	38 NC		
9 R4	19 G5	29 B6	39 NC		
10 R5	20 G6	30 B7	40 NC		

				DATE:	2015/05/13	TITLE: LCM OUTLINE DIMENSION	
				DRAWN:		DWG. NO.	FG04032PUG01
				CHECK:		UNITS	M M
				APPROVE:		SCALE	1:1
						REV.	2
						SHEET 1 OF 1	

AUTH	DESCRIPTION	DATE	APPROVED
	Change protection tape on FPC component area& tolerance of FPC length. ECR<11S-F70028>	2015/07/22	
	ESR S1505003		

## 14. PACKAGE INFORMATION

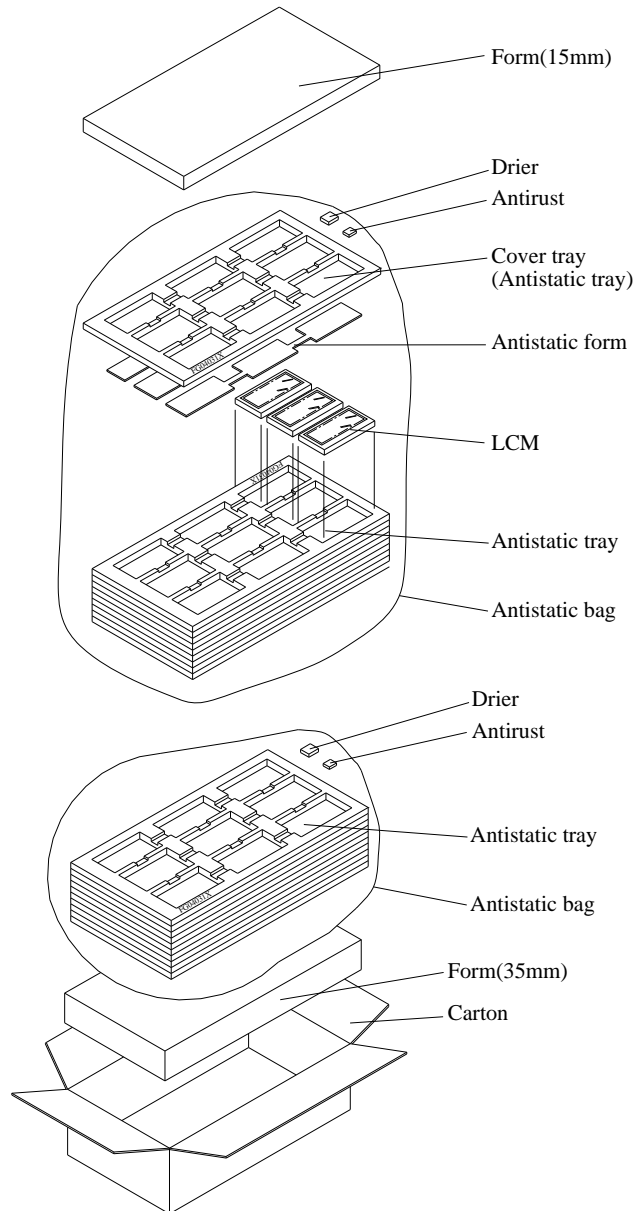

### Material

1 Carton + 1 Form (15mm) + 2 Anti-static bag + 20 Anti-static tray  
+ 2 Drier + 2 Antirust + 1 Form (35mm)

### Total pcs

1 Antistatic tray = 9 pcs (modules)

1 Anti-static bag = 9 Anti-static tray + cover tray =  $9 \times 9 + 1 \times 0 = 81$  pcs

1 Carton = 2 Anti-static bag =  $2 \times 81 = 162$  pcs

1 Carton = 162 pcs

Carton size : 465L x 380W x 395H (mm)

Total Weight  $\div$  11.6 kgw