

# ***TFT-Display Datenblatt***

Modell FG0700A2DSSWBG01

## **Kurzdaten**

Hersteller	Data Image
Diagonale	7" / 17,8cm
Format	15:9
Auflösung	800x480
Backlight	LED/ 320cd/m <sup>2</sup>
Interface	LVDS
Touchscreen	nein
Temperatur	-20...+70°C (Betrieb)



Confidential Document

# DATA IMAGE CORPORATION

## TFT Module Specification

ITEM NO.: FG0700A2DSSWBG01

### Table of Contents

1. COVER & CONTENTS .....	1
2. RECORD OF REVISION .....	2
3. APPLICATION.....	3
4. GENERAL SPECIFICATIONS .....	3
5. ABSOLUTE MAXIMUM RATINGS .....	3
6. ELECTRICAL CHARACTERISTICS .....	3
7. TIMING SPECIFICATIONS .....	4
8. OPTICAL CHARACTERISTIC .....	7
9. PIN CONNECTIONS .....	10
10. BLOCK DIAGRAM .....	12
11. QUALITY ASSURANCE .....	13
12. LCM PRODUCT LABEL DEFINE.....	14
13. PRECAUTIONS IN USE LCM .....	16
14. OUTLINE DRAWING .....	17
15. PACKAGE INFORMATION.....	18

Customer Companies	R&D Dept.	Q.C. Dept.	Eng. Dept.	Prod. Dept.
	<i>Jack</i>	<i>Joe</i>	<i>Gang</i>	<i>Ben</i>
Approved by	Version:	Issued Date:	Sheet Code:	Total Pages:
	B	5/MAY/11'		18

**2. RECORD OF REVISION**

Rev	Date	Item	Page	Comment
1	28/MAY/08'			New preliminary
2	21/AUG/08'	6,8,11, 16	3,7,13, 17	1. Modify "LED life time" to "LED dice life time", value and note. 2. Modify Response time value, Rise 15(Typ) 30(Max), Fall 20 (Typ)40(Max) to Rise 5(Typ)10(Max) Fall15(Typ)20(Max). 3. Modify Temperature cycle test value, from -20 →+25 → +70 , 100 Cycles to -30 →+25 → +80 , 100 Cycles. 4. Modify OUTLINE DRAWING from Rev:B to Rev:C.
3	5/JAN/09'	16	17	Modify PACKAGE INFORMATION
A	20/Feb/09'	16	17	Release Rev. A for production. Modify PACKAGE INFORMATION.
B	5/MAY/11'	4 12 14	7 14 17	1. Delete NOTE 2. Modify LCM PRODUCT LABEL DEFINE 3. Modify OUTLINE DRAWING FROM Rev C to D

### 3. APPLICATION

DVD player, Car TV, UMPC, POS

### 4. GENERAL SPECIFICATIONS

Parameter	Specifications	Unit
Screen Size	7 (diagonal)	inch
Display Format	800(H) x (R,G,B) x 480(V)	dot
Active Area	152.4(H) x 91.44(V)	mm
Dot Pitch	0.0635 (H) x 0.1905 (V)	mm
Pixel Configuration	Stripe	
Outline Dimension	165(W) x 104(H) x 6.3 (D)	mm
Surface treatment	Anti-glare and hard coating (3H)	
Back-light	LED	
Display mode	Normally white	
Weight	110	g
View Angle direction	6 o'clock	

### 5. ABSOLUTE MAXIMUM RATINGS

Parameter	Symbol	MIN.	MAX.	Unit	Remark
Power supply voltage	V <sub>CC</sub>	-0.3	5.0	V	Ta=25°C
Logic input voltage	V <sub>I</sub>	-0.3	V <sub>CC</sub> +0.3	V	
Operating temperature	T <sub>OP</sub>	-20	+70	°C	Module surface*
Storage temperature	T <sub>ST</sub>	-30	+80	°C	-
Humidity	Operation	20%~90% relative humidity			Ta<=38°C
	Non Operation	5%~90% relative humidity			Ta<=38°C

### 6. ELECTRICAL CHARACTERISTICS

f<sub>H</sub>=30KHz, f<sub>V</sub>=60Hz, f<sub>CLK</sub>=27MHz, Ta=25°C

Parameter	Symbol	MIN.	Typ.	MAX.	Unit	Remark
Power Supply voltage for LCD	V <sub>CC</sub>	+3.0	+3.3	+3.6	V	
Power Supply Current for LCD	I <sub>CC</sub>		150	200	mA	V <sub>CC</sub> =3.3V
Power Supply voltage for LED	V <sub>DD</sub>	3	3.3	5.5	V	
Power Supply Current for LED	I <sub>DD</sub>		650	850	mA	V <sub>DD</sub> =3.3V
Power Supply Current for LED	I <sub>DD</sub>		400	550	mA	V <sub>DD</sub> =5.0V
Ripple voltage	V <sub>RF</sub>	-	-	100	mV <sub>P-P</sub>	
“H” level logical input voltage	V <sub>IH</sub>	0.7V <sub>CC</sub>	--	V <sub>CC</sub>	V	
“L” level logical input voltage	V <sub>IL</sub>	0	--	0.3V <sub>CC</sub>	V	
ADJ frequency		19K	20K	21K	Hz	
ADJ input voltage	V <sub>IH</sub>	3.0	-	3.3	V	
	V <sub>IL</sub>	0	-	0.3	V	
LED dice life time			30000		Hr	Note 1

Note 1: The “LED dice life time” is defined as the brightness decrease to 50% original brightness that the ambient temperature is 18 ~28 and LED dice current=20mA.

## 7. TIMING SPECIFICATIONS

ITEM		SYMBOL	MIN.	TYP.	MAX.	UNIT
DCLK	Period	$t_{CLK}$	31	37.0	40.0	ns
	Dot Clock	$f_{CLK}$	25	27	32.11	MHz
	Low Level Width	$t_{WCL}$	8	-	-	ns
	High Level Width	$t_{WCH}$	8	-	-	
DE	Setup Time	$t_{DES}$	5	-	-	ns
	Hold time	$t_{DEH}$	10	-	-	
	Horizontal Period	$t_{HP}$	850	900	950	$t_{CLK}$
	Horizontal Valid	$t_{HV}$	800			
	Horizontal Blank	$t_{HBK}$	50	100	150	
	Vertical Period	$t_{VP}$	490	500	520	$t_{HP}$
	Vertical Valid	$t_{VV}$	480			
	Vertical Blank	$t_{VBK}$	10	20	40	
	Vertical Frequency	$f_V$	55	60	65	Hz
DATA	Setup Time	$t_{DS}$	5	-	-	ns
	Hold Time	$t_{DH}$	10	-	-	

### 7.1 TIMING CHARACTERISTIC :

#### 7.1.1 Timing Chart

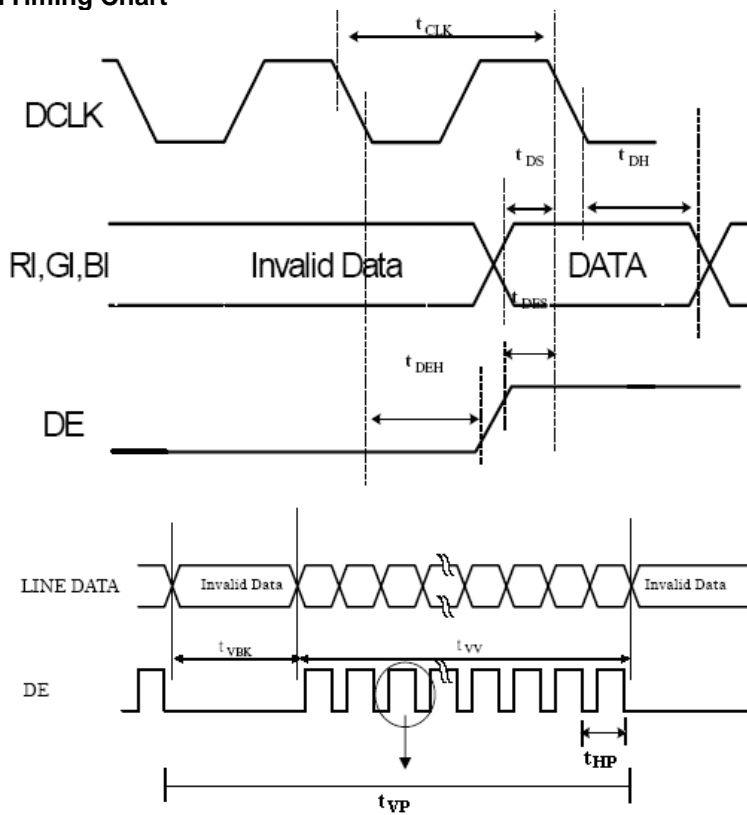

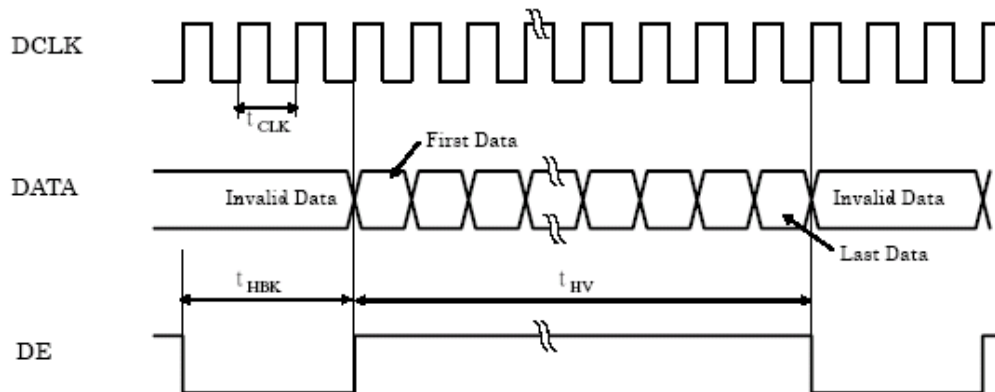

### 7.2 Color Data Input Assignment

		Data Signal																	
		Red					Green					Blue							
Color		R5	R4	R3	R2	R1	R0	G5	G4	G3	G2	G1	G0	B5	B4	B3	B2	B1	B0
Basic Colors	Black	0	0	0	0	0	0	0	0	0	0	0	0	0	0	0	0	0	0
	Red	1	1	1	1	1	1	0	0	0	0	0	0	0	0	0	0	0	0
	Green	0	0	0	0	0	0	1	1	1	1	1	1	0	0	0	0	0	0
	Blue	0	0	0	0	0	0	0	0	0	0	0	0	1	1	1	1	1	1
	Cyan	0	0	0	0	0	0	1	1	1	1	1	1	1	1	1	1	1	1
	Magenta	1	1	1	1	1	1	0	0	0	0	0	0	1	1	1	1	1	1
	Yellow	1	1	1	1	1	1	1	1	1	1	1	1	0	0	0	0	0	0
	White	1	1	1	1	1	1	1	1	1	1	1	1	1	1	1	1	1	1
Gray Scale of Red	Red(0) / Dark	0	0	0	0	0	0	0	0	0	0	0	0	0	0	0	0	0	0
	Red(1)	0	0	0	0	0	1	0	0	0	0	0	0	0	0	0	0	0	0
	Red(2)	0	0	0	0	1	0	0	0	0	0	0	0	0	0	0	0	0	0
	:	:	:	:	:	:	:	:	:	:	:	:	:	:	:	:	:	:	:
	:	:	:	:	:	:	:	:	:	:	:	:	:	:	:	:	:	:	:
	Red(61)	1	1	1	1	0	1	0	0	0	0	0	0	0	0	0	0	0	0
	Red(62)	1	1	1	1	1	0	0	0	0	0	0	0	0	0	0	0	0	0
Red(63)	1	1	1	1	1	1	0	0	0	0	0	0	0	0	0	0	0	0	
Gray Scale of Green	Green(0)/ Dark	0	0	0	0	0	0	0	0	0	0	0	0	0	0	0	0	0	0
	Green(1)	0	0	0	0	0	0	0	0	0	0	0	1	0	0	0	0	0	0
	Green(2)	0	0	0	0	0	0	0	0	0	0	1	0	0	0	0	0	0	0
	:	:	:	:	:	:	:	:	:	:	:	:	:	:	:	:	:	:	:
	:	:	:	:	:	:	:	:	:	:	:	:	:	:	:	:	:	:	:
	Green(61)	0	0	0	0	0	0	1	1	1	1	0	1	0	0	0	0	0	0
	Green(62)	0	0	0	0	0	0	1	1	1	1	1	0	0	0	0	0	0	0
Green(63)	0	0	0	0	0	0	1	1	1	1	1	1	0	0	0	0	0	0	
Gray Scale of Blue	Blue(0)/ Dark	0	0	0	0	0	0	0	0	0	0	0	0	0	0	0	0	0	0
	Blue (1)	0	0	0	0	0	0	0	0	0	0	0	0	0	0	0	0	0	1
	Blue (2)	0	0	0	0	0	0	0	0	0	0	0	0	0	0	0	0	1	0
	:	:	:	:	:	:	:	:	:	:	:	:	:	:	:	:	:	:	:
	:	:	:	:	:	:	:	:	:	:	:	:	:	:	:	:	:	:	:
	Blue (61)	0	0	0	0	0	0	0	0	0	0	0	0	1	1	1	1	0	1
	Blue (62)	0	0	0	0	0	0	0	0	0	0	0	0	1	1	1	1	1	0
Blue (63)	0	0	0	0	0	0	0	0	0	0	0	0	1	1	1	1	1	1	

### Correspondence between Data and Display Position

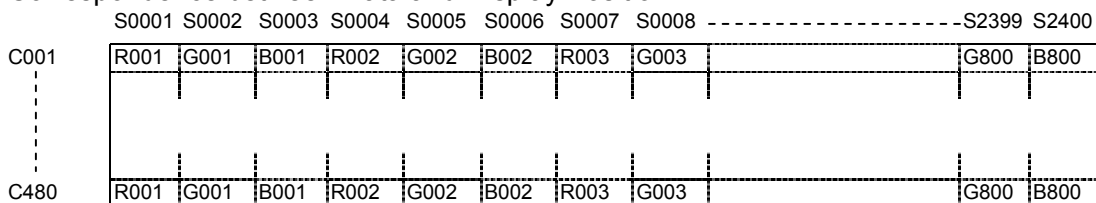

## 8. OPTICAL CHARACTERISTIC

### 8-1. Specification:

Parameter	Symbol	Condition	MIN.	TYP.	MAX.	Unit	Remarks	
Viewing Angle	Horizontal	$\theta_{x+}$	60	70	--	deg	Note 1,4	
		$\theta_{x-}$	60	70	--			
	Vertical	$\theta_{y+}$	Center CR $\geq$ 10	40	50			--
		$\theta_{y-}$		50	60			--
Contrast Ratio	CR	at optimized viewing angle	300	400			Note 1,3	
Response time	Rise	Tr	-	5	10	ms	Note 1,7	
	Fall	Tf	-	15	20	ms		
Uniformity		B-uni	$\theta_{x=\theta_{y=0^{\circ}}}$	70	80	--	%	Note1,5
Brightness		L	$\theta_{x=\theta_{y=0^{\circ}}}$ ADJ=3.3V	250	320	--	cd/m <sup>2</sup>	Note 1,2
Chromaticity	$x_W$	Center $\theta_{x=\theta_{y=0^{\circ}}}$	0.267	0.307	0.347		Note 1,7	
	$y_W$		0.299	0.339	0.379			
	$x_R$		0.562	0.602	0.642			
	$y_R$		0.314	0.354	0.394			
	$x_G$		0.278	0.318	0.358			
	$y_G$		0.496	0.536	0.576			
	$x_B$		0.104	0.144	0.184			
	$y_B$		0.089	0.129	0.169			
Image sticking	tis	2 hours			2	Sec	Note 8	

The following optical specifications shall be measured in a darkroom or equivalent state (ambient luminance  $\leq$ 1 lux, and at room temperature). The operation temperature is 25°C $\pm$ 2°C. The measurement method is shown in Note1.

Note1: The method of optical measurement:

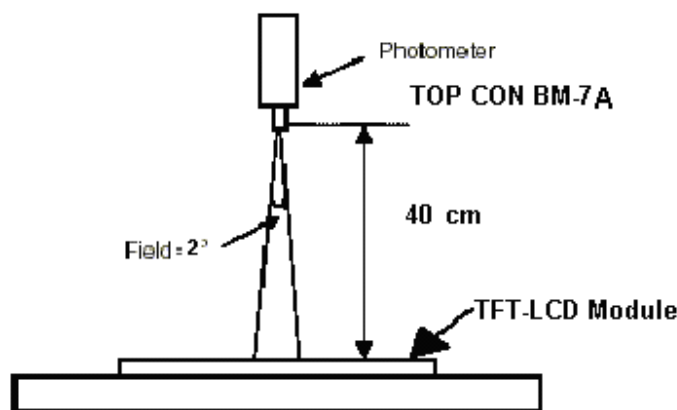



Note2: Measured at the center area of the panel and at the viewing angle of the  $\theta_x = \theta_y = 0^\circ$

Note3: Definition of Contrast Ratio (CR):

$$CR = \frac{\text{Luminance with all pixels in white state}}{\text{Luminance with all pixels in Black state}}$$

Note4: Definition of Viewing Angle

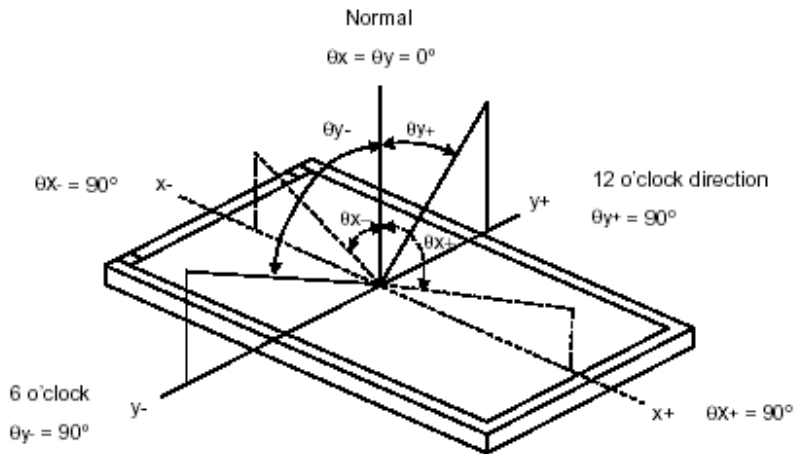

Note 5: Definition of Brightness Uniformity (B-uni):

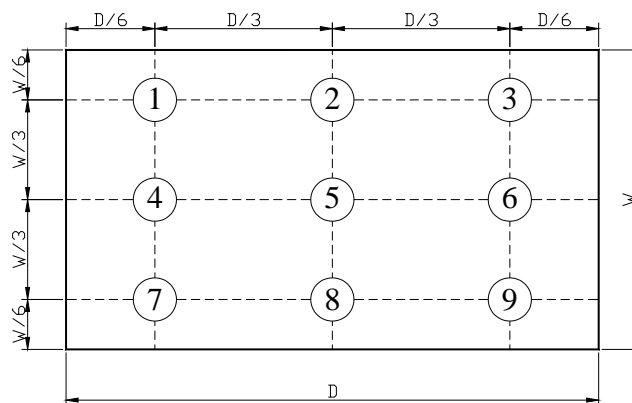

$$B\text{-uni} = \frac{\text{Minimum luminance of 9 points}}{\text{Maximum luminance of 9 points}} \quad (\text{Note 5}).$$

Note6: Definition of Response Time:

The Response Time is set initially by defining the “Rising Time ( $T_r$ )” and the “Falling Time ( $T_f$ )” respectively.  $T_r$  and  $T_f$  are defined as following figure.

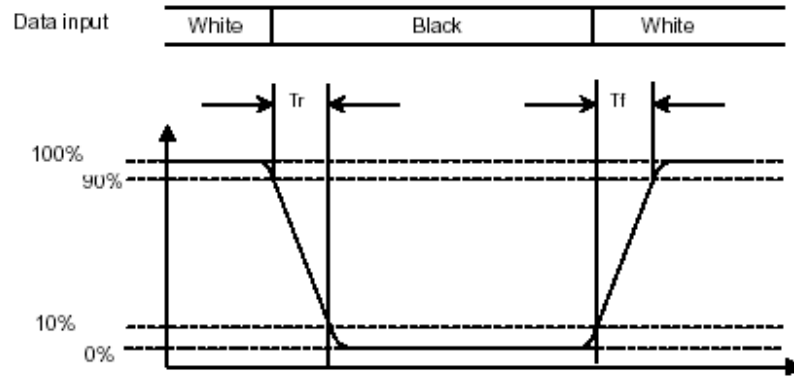

Note 7: Definition of Chromaticity:

The color coordinates  $(x_w, y_w)$ ,  $(x_r, y_r)$ ,  $(x_g, y_g)$ , and  $(x_b, y_b)$  are obtained with all pixels in the viewing field at white, red, green, and blue states, respectively.

Note 8: Definition of Image sticking (tis):

Continuously display the test pattern shown in the figure below for 2 hours. Then display a completely white screen. The previous image shall not persist more than 2 sec at 25 °C

**Image sticking pattern**

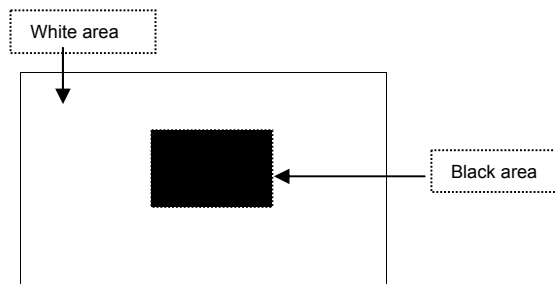

## 9. PIN CONNECTIONS

### 9.1 TFT PIN Connections (CON1)

Pin No	Symbol	Function	Remark
1	VCC	power supply for Digital Circuit	
2	VCC	power supply for Digital Circuit	
3	GND	Ground	
4	GND	Ground	
5	RxIN0-	Differential Data Input ,CH0(Negative)	
6	RxIN0+	Differential Data Input ,CH0(Positive)	
7	GND	Ground	
8	RxIN1-	Differential Data Input ,CH1(Negative)	
9	RxIN1+	Differential Data Input ,CH1(Positive)	
10	GND	Ground	
11	RxIN2-	Differential Data Input ,CH2(Negative)	
12	RxIN2+	Differential Data Input ,CH2(Positive)	
13	GND	Ground	
14	CKIN-	Differential Clock Input (Negative)	
15	CKIN+	Differential Clock Input (Positive)	
16	GND	Ground	
17	VDD	Power Supply for LED Driver Circuit	
18	VDD	Power Supply for LED Driver Circuit	
19	GND	Ground	
20	ADJ	Brightness control for LED B/L	

### 9.2 LED PIN Connections (CON2)

Pin No	Symbol	Function	Remark
1	VDD	Power Supply for LED Driver Circuit	
2	VDD	Power Supply for LED Driver Circuit	
3	GND	Ground	
4	GND	Ground	
5	ADJ	Brightness control for LED B/L	

Remarks :

- 1) ADJ is brightness control Pin. The larger of the pulse duty is, the higher of the brightness.
- 2) ADJ signal is 0~3.3V. Operation frequency is 20KHz
- 3) GND PIN must be grounding, can not be floating.

### 9.3 Power Signal Sequence

Remarks:

\*1) Power Signal sequence:

$t_1 \leq 10\text{ms}$  ;  $1 \text{ sec} \leq t_5$

$50\text{ms} \leq t_2$  ;  $200\text{ms} \leq t_6$

$0 < t_3 \leq 50\text{ms}$  ;  $200\text{ms} \leq t_7$

$0 < t_4 \leq 10\text{ms}$

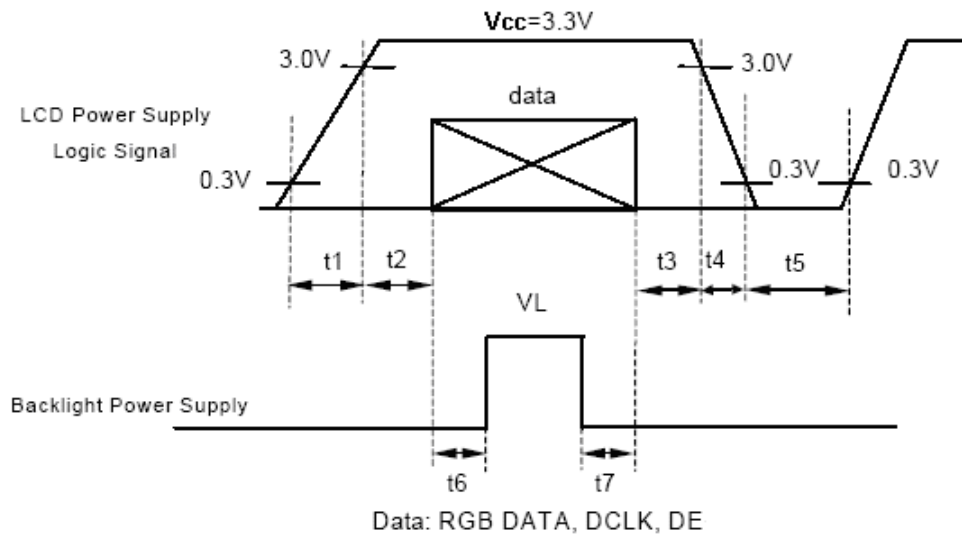

VCC-dip condition:

(1)  $2.7 \text{ V} \leq V_{CC} < 3.0\text{V}$ ,  $t_d \leq 10 \text{ ms}$

(2)  $V_{CC} > 3.0\text{V}$ , VCC-dip condition should be the same with VCC-turn-on condition.

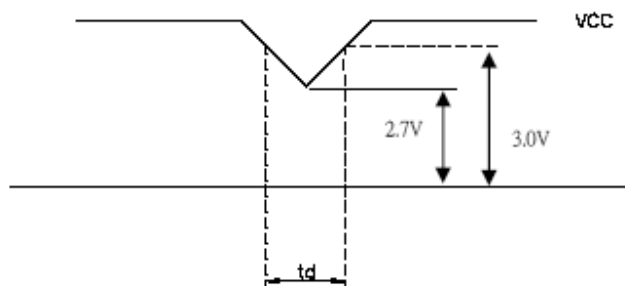

**10. BLOCK DIAGRAM**

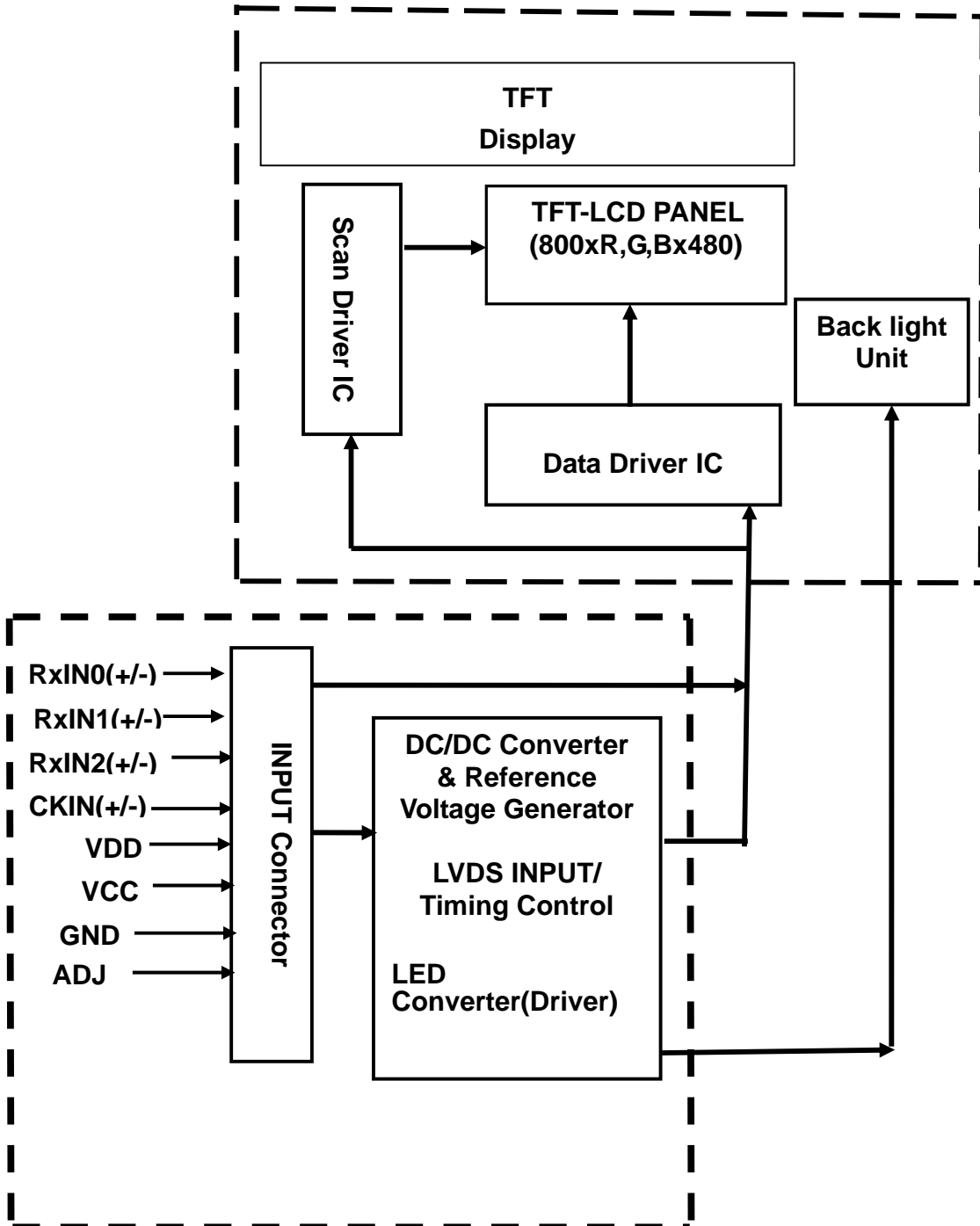

## 11. QUALITY ASSURANCE

### 11.1 Test Condition

#### 11.1.1 Temperature and Humidity(Ambient Temperature)

Temperature :  $25 \pm 5^{\circ}\text{C}$

Humidity :  $65 \pm 5\%$

#### 11.1.2 Operation

Unless specified otherwise, test will be conducted under function state.

#### 11.1.3 Container

Unless specified otherwise, vibration test will be conducted to the product itself without putting it in a container.

#### 11.1.4 Test Frequency

In case of related to deterioration such as shock test. It will be conducted only once.

#### 11.1.5 Test Method

Reliability Test Item & Level		Test Level
No.	Test Item	
1	High Temperature Storage Test	T=80 ,240hrs
2	Low Temperature Storage Test	T=-30 ,240hrs
3	High Temperature Operation Test	T=70 ,240hrs
4	Low Temperature Operation Test	T=-20 ,240hrs
5	High Temperature and High Humidity Operation Test	T=60 ,90%RH,240hrs
6	Thermal Cycling Test (No operation)	-30 → +25 → +80 , 100 Cycles 30 min 5 min 30 min
7	Vibration Test (No operation)	Frequency :10 ~ 55 Hz Amplitude :1.5 mm Sweep time : 11 mins Test Period: 6 Cycles for each direction of X, Y, Z
8	Shock Test (No operation)	100G, 6ms Direction: ±X, ±Y, ±Z Cycle: 3 times

## 12. LCM PRODUCT LABEL DEFINE

Product Label style:

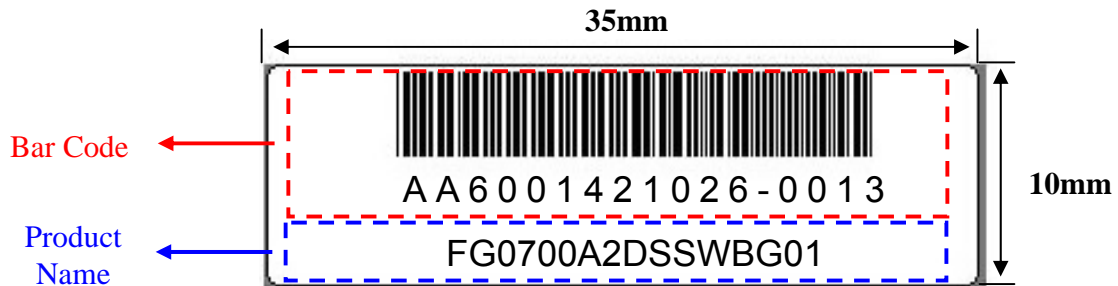

BarCode Define:

**A A 6 0014 2 10 26-0013**

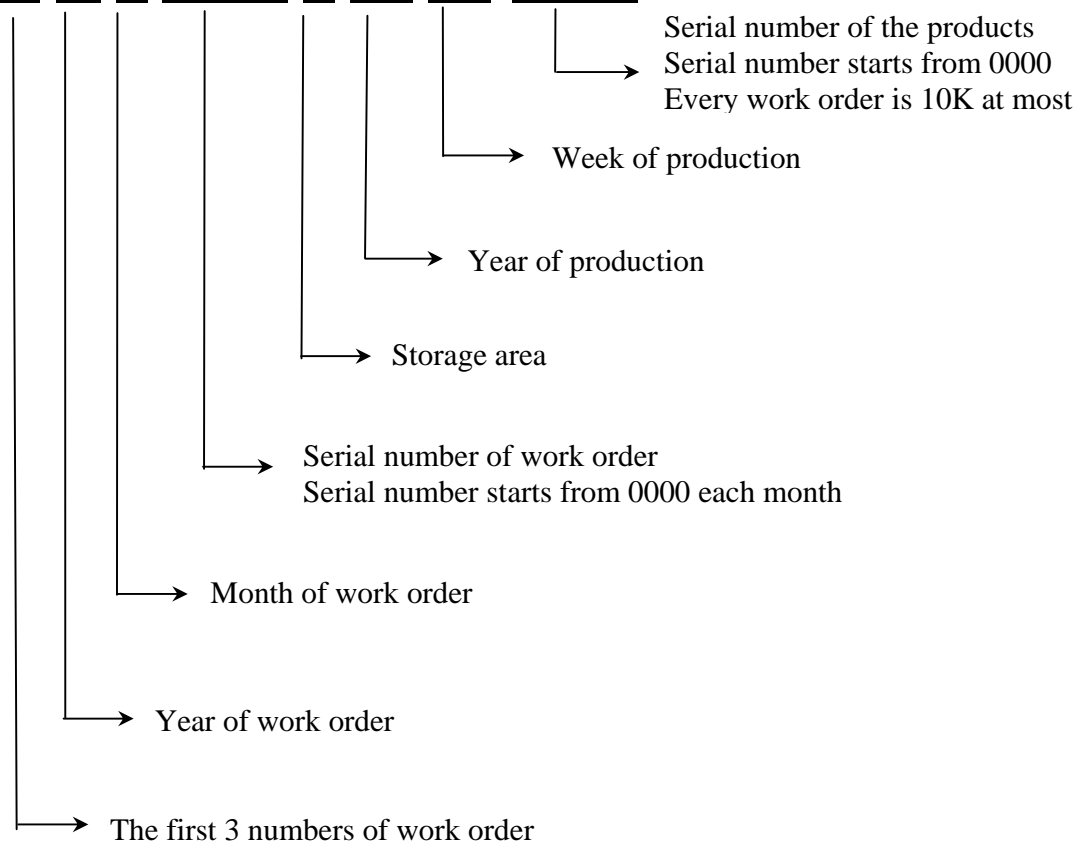

**Product Name Define:**

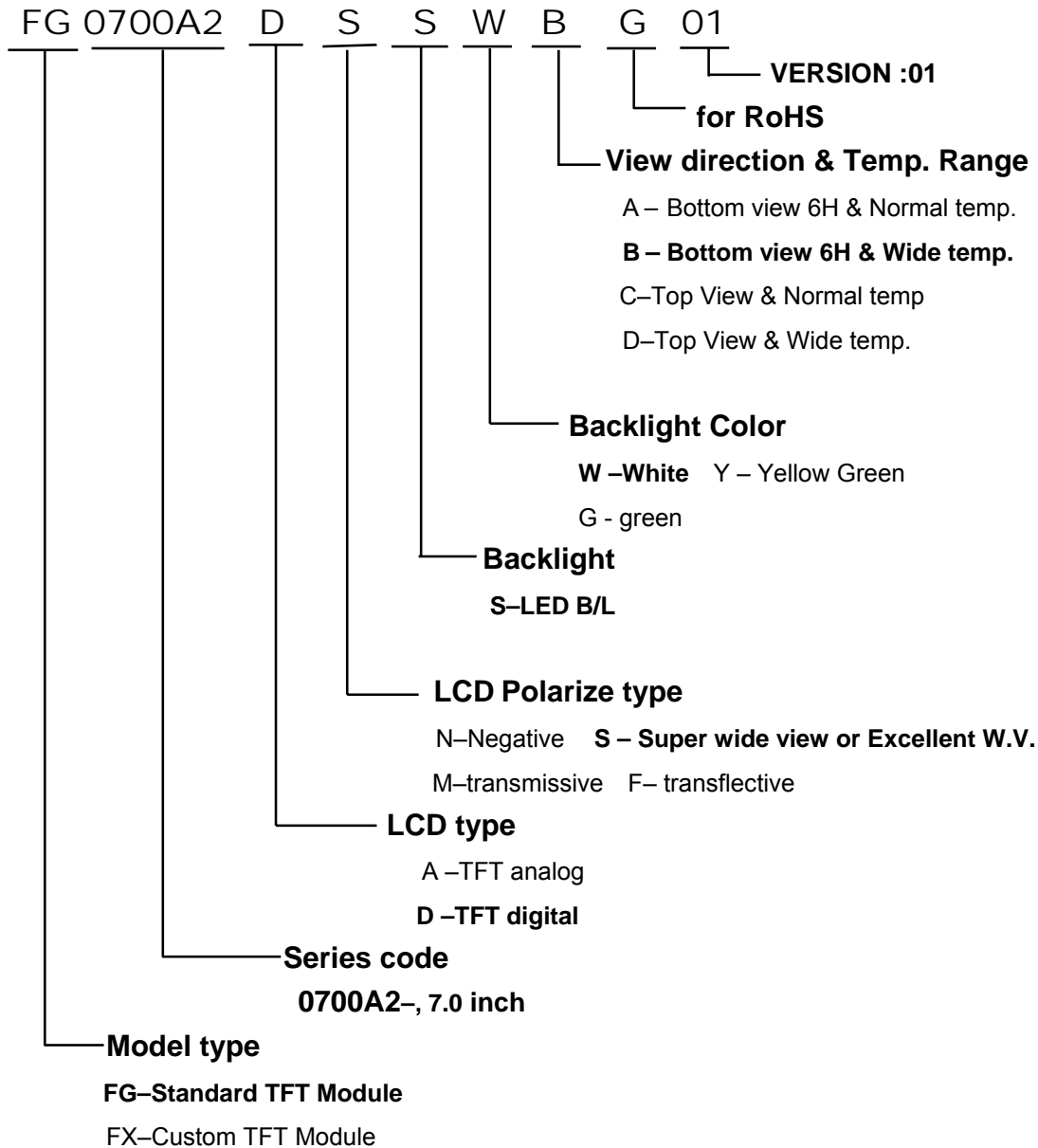



## 13. RECAUTION FOR USING LCM

### 1. LIQUID CRYSTAL DISPLAY (LCD)

LCD is made up of glass, organic sealant, organic fluid, and polymer based polarizers. The following precautions should be taken when handling,

- (1). Keep the temperature within range of use and storage. Excessive temperature and humidity could cause polarization degradation, polarizer peel off or bubble.
- (2). Do not contact the exposed polarizers with anything harder than an HB pencil lead. To clean dust off the display surface, wipe gently with cotton, chamois or other soft material soaked in petroleum benzine.
- (3). Wipe off saliva or water drops immediately. Contact with water over a long period of time may cause polarizer deformation or color fading, while an active LCD with water condensation on its surface will cause corrosion of ITO electrodes.
- (4). Glass can be easily chipped or cracked from rough handling, especially at corners and edges.
- (5). Do not drive LCD with DC voltage.

### 2. Liquid Crystal Display Modules

#### 2.1 Mechanical Considerations

LCM are assembled and adjusted with a high degree of precision. Avoid excessive shocks and do not make any alterations or modifications. The following should be noted.

- (1). Do not tamper in any way with the tabs on the metal frame.
- (2). Do not modify the PCB by drilling extra holes, changing its outline, moving its components or modifying its pattern.
- (3). Do not touch the elastomer connector, especially insert an backlight panel (for example, EL).
- (4). When mounting a LCM make sure that the PCB is not under any stress such as bending or twisting. Elastomer contacts are very delicate and missing pixels could result from slight dislocation of any of the elements.
- (5). Avoid pressing on the metal bezel, otherwise the elastomer connector could be deformed and lose contact, resulting in missing pixels.

#### 2.2. Static Electricity

LCM contains CMOS LSI's and the same precaution for such devices should apply, namely

- (1). The operator should be grounded whenever he/she comes into contact with the module. Never touch any of the conductive parts such as the LSI pads, the copper leads on the PCB and the interface terminals with any parts of the human body.
- (2). The modules should be kept in antistatic bags or other containers resistant to static for storage.
- (3). Only properly grounded soldering irons should be used.
- (4). If an electric screwdriver is used, it should be well grounded and shielded from commutator sparks.

(5) The normal static prevention measures should be observed for work clothes and working benches; for the latter conductive (rubber) mat is recommended.

(6). Since dry air is inductive to statics, a relative humidity of 50-60% is recommended.

### 2.3 Soldering

- (1). Solder only to the I/O terminals.
- (2). Use only soldering irons with proper grounding and no leakage.
- (3). Soldering temperature :  $280^{\circ}\text{C} \pm 10^{\circ}\text{C}$
- (4). Soldering time: 3 to 4 sec.
- (5). Use eutectic solder with resin flux fill.
- (6). If flux is used, the LCD surface should be covered to avoid flux spatters. Flux residue should be removed after wards.

### 2.4 Operation

- (1). The viewing angle can be adjusted by varying the LCD driving voltage  $V_0$ .
- (2). Driving voltage should be kept within specified range; excess voltage shortens display life.
- (3). Response time increases with decrease in temperature.
- (4). Display may turn black or dark blue at temperatures above its operational range; this is (however not pressing on the viewing area) may cause the segments to appear "fractured".
- (5). Mechanical disturbance during operation (such as pressing on the viewing area) may cause the segments to appear "fractured".

### 2.5 Storage

If any fluid leaks out of a damaged glass cell, wash off any human part that comes into contact with soap and water. Never swallow the fluid. The toxicity is extremely low but caution should be exercised at all the time.

### 2.6 Limited Warranty

Unless otherwise agreed between DATA IMAGE and customer, DATA IMAGE will replace or repair any of its LCD and LCM which is found to be defective electrically and visually when inspected in accordance with DATA IMAGE acceptance standards, for a period on one year from date of shipment. Confirmation of such date shall be based on freight documents. The warranty liability of DATA IMAGE is limited to repair and/or replacement on the terms set forth above. DATA IMAGE will not responsible for any subsequent or consequential events.

Confidential Document  
**14. OUTLINE DRAWING**

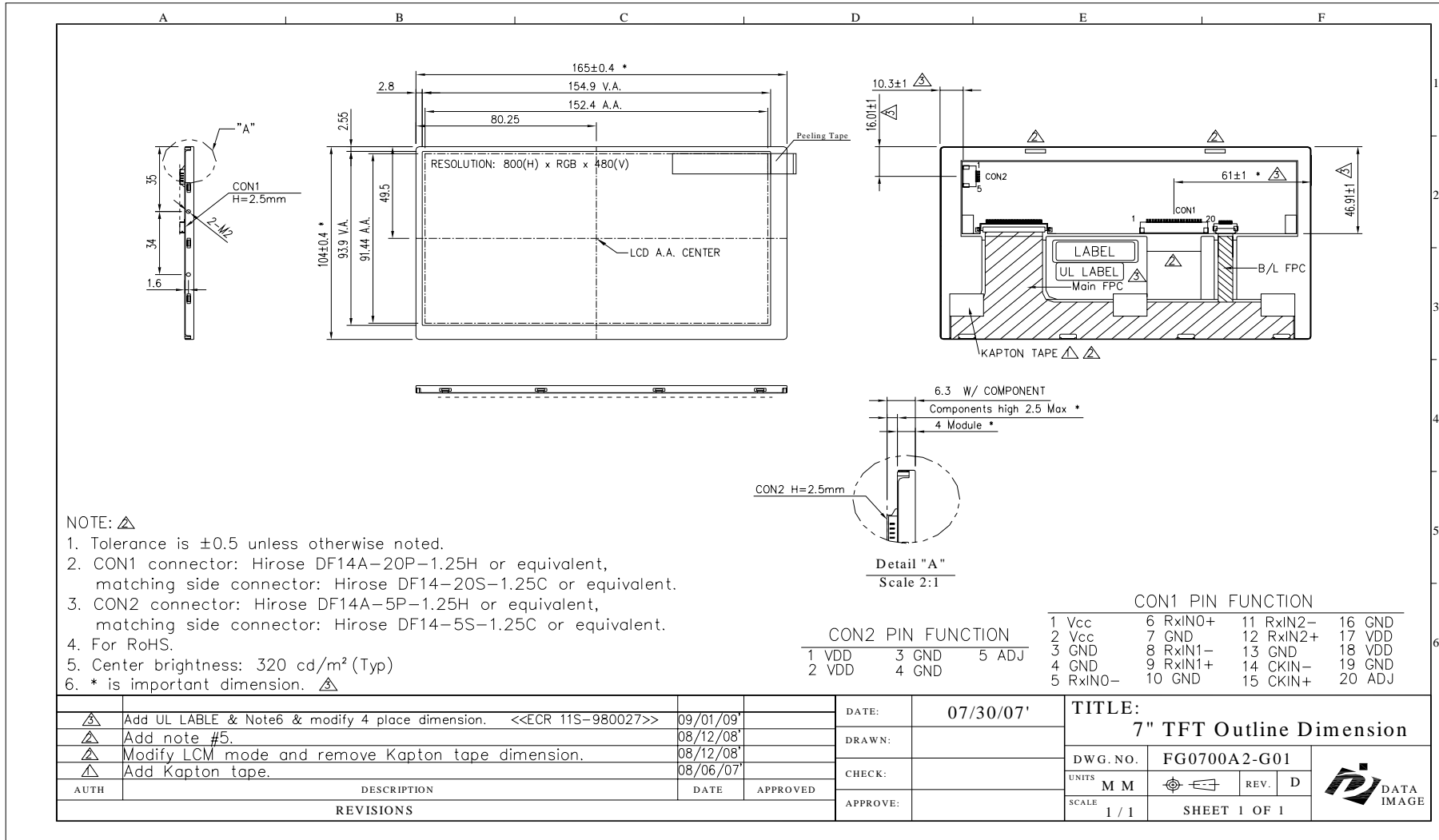

## 15. PACKAGE INFORMATION

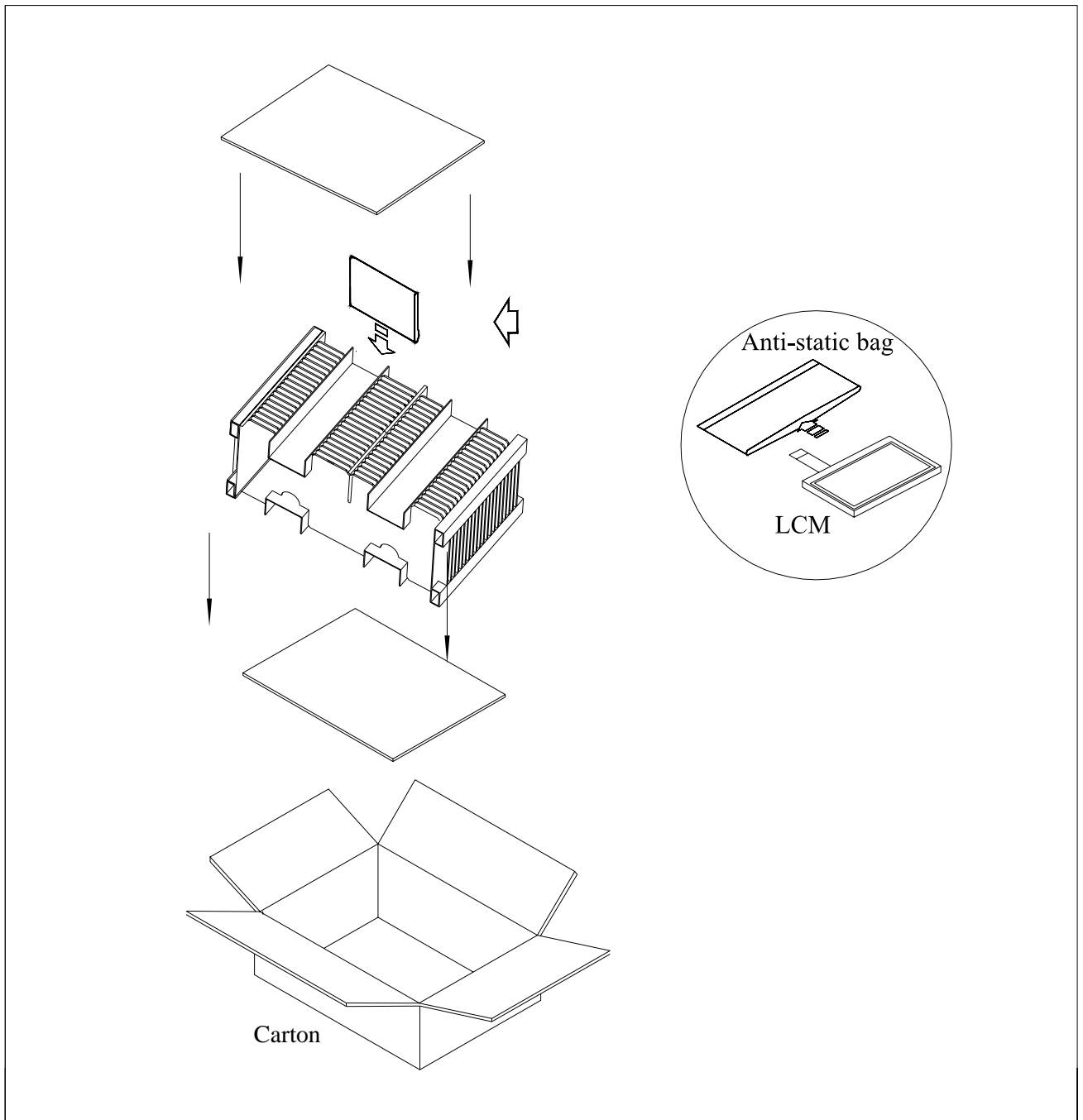

Item	Size(L*W*H)	Quantity	Note
Master Carton	482*282*279	1	
Quantity Per Master Carton		38	
N . W	4.2 (kg)	G . W	6.6 (kg)