

## ***TFT-Display Datenblatt***

Modell FG080036DSSWAGT1

### **Kurzdaten**

Hersteller	Datamagic
Diagonale	8,0" / 20,3cm
Format	4:3
Auflösung	800x600
Backlight	LED/240cd/m <sup>2</sup>
Temperatur	-10...+60°C (Betrieb)



# DATA IMAGE CORPORATION

## TFT Module Specification

ITEM NO.: FG080036DSSWAGT1

### Table of Contents

1. COVER & CONTENTS .....	1
2. RECORD OF REVISION .....	2
3. GENERAL SPECIFICATIONS .....	3
4. ABSOLUTE MAXIMUM RATINGS .....	3
5. ELECTRICAL CHARACTERISTICS .....	3
6. INTERFACE SPECIFICATIONS .....	4
7. OPTICAL CHARACTERISTIC .....	7
8. PIN CONNECTIONS .....	10
9. BLOCK DIAGRAM .....	12
10. TOUCH PANEL CHARACTERISTICS .....	13
11. QUALITY ASSURANCE .....	14
12. LOT NUMBERING SYSTEM .....	15
13. LCM NUMBERING SYSTEM .....	15
14. PRECAUTIONS IN USE LCM .....	16
15. OUTLINE DRAWING .....	17
16. PACKAGE INFORMATION.....	18

Customer Companies	R&D Dept.	Q.C. Dept.	Eng. Dept.	Prod. Dept.
	<i>Alex</i>	<i>Eric</i>	<i>Paul</i>	<i>Heien</i>
Approved by	Version:	Issued Date:	Sheet Code:	Total Pages:
	A	2008/10/21		18

**2. RECORD OF REVISION**

Rev	Date	Item	Page	Comment
1	30/JUN/08			Initial PRELIMINARY
A	17/OCT/08	3,5,15	3,17	1. Release Rev: A for production. 2. Add Weight data. 3. Add Power Supply Current (ICC). 4. Modify OUTLINE DRAWING from Rev: 1 to Rev: A

### 3. GENERAL SPECIFICATIONS

Parameter	Specifications	Unit
Screen Size	8 (diagonal)	inch
Display Format	800(H) x (R,G,B) x 600(V)	dot
Active Area	162(H) x 121.5 (V)	mm
Dot Pitch	0.0675 (H) x 0.2025 (V)	mm
Pixel Configuration	R.G.B.-Stripe	
Outline Dimension	183(W) x 141(H) x 10.2 (D) Max.	mm
Surface treatment	Anti-glare	
Back-light	LED	
Display mode	Normally white	
Weight	335	g
View Angle direction	6 o'clock	
Our components and processes are compliant to RoHS standard		

### 4. ABSOLUTE MAXIMUM RATINGS

GND= 0V

Parameter	Symbol	MIN.	MAX.	Unit	Remark
Power supply voltage	V <sub>CC</sub>	-0.3	+4.0	V	
Logic input voltage	V <sub>I</sub>	-0.3	V <sub>CC</sub> +0.3	V	
Operating temperature	Top	-10	60	°C	
Storage temperature	T <sub>st</sub>	-30	70	°C	-

### 5. ELECTRICAL CHARACTERISTICS

#### A) Module

GND= 0V, Ta=25°C, DCLK=39.79 MHz

Parameter	Symbol	MIN.	Typ.	MAX.	Unit	Remark
Power Supply voltage	V <sub>CC</sub>	3.0	3.3	3.6	V	
Power Supply Current	I <sub>CC</sub>	--	220	350	mA	V <sub>CC</sub> =3.3V
Ripple voltage	V <sub>RF</sub>	-	-	100	mV <sub>P-P</sub>	

#### B) Backlight Driving Conditions

Ta=25°C

Parameter	Symbol	MIN.	Typ.	MAX.	Unit	Remark
LED Voltage	V <sub>L</sub>	9		10.5	V	Note 1
LED Current	I <sub>L</sub>	--	200	--	mA	
LED Life time		30000			Hr	Note 2

Note 1: V<sub>L</sub>=A-K

Note 2: The "LED life time" is defined as the module brightness decrease to 50% original brightness that the ambient temperature is 25 and I<sub>L</sub> =200mA.

## 6. INTERFACE SPECIFICATIONS

### 6.1 Input signal characteristics

#### 6.1.1 AC Electrical Characteristics

Parameter	Symbol	MIN.	TYP.	MAX.	Unit
Data setup time	$T_{dsu}$	6	-	-	ns
Data hold time	$T_{dhd}$	6	-	-	ns
DEN setup time	$T_{esu}$	6	-	-	ns

#### 6.1.2 Resolution : 800x600

Parameter	Symbol	MIN.	TYP.	MAX.	Unit
CLK frequency	$F_{CPH}$	30.5	39.79	42	MHz
CLK period	$T_{CPH}$	23.81	25.13	32.79	ns
CLK pulse duty	$T_{CWH}$	40	50	60	%
DE period	$T_{DEH}+T_{DEL}$	1000	1056	1200	$T_{CPH}$
DE pulse width	$T_{DH}$	-	800	-	$T_{CPH}$
DE frame blanking	$T_{DEB}$	10	28	110	$T_{DEH}+T_{DEL}$
DE frame width	$T_{DE}$	-	600	-	$T_{DEH}+T_{DEL}$

## 6.2 Timing Controller Timing Chart

### 6.2.1 Clock and Data input waveforms

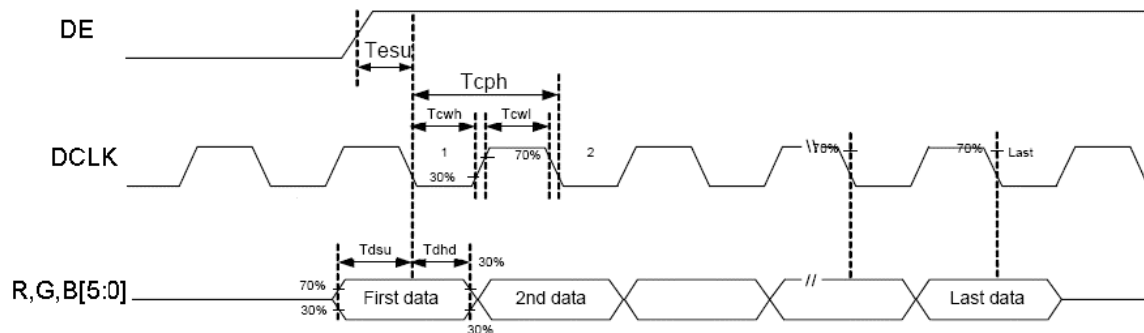
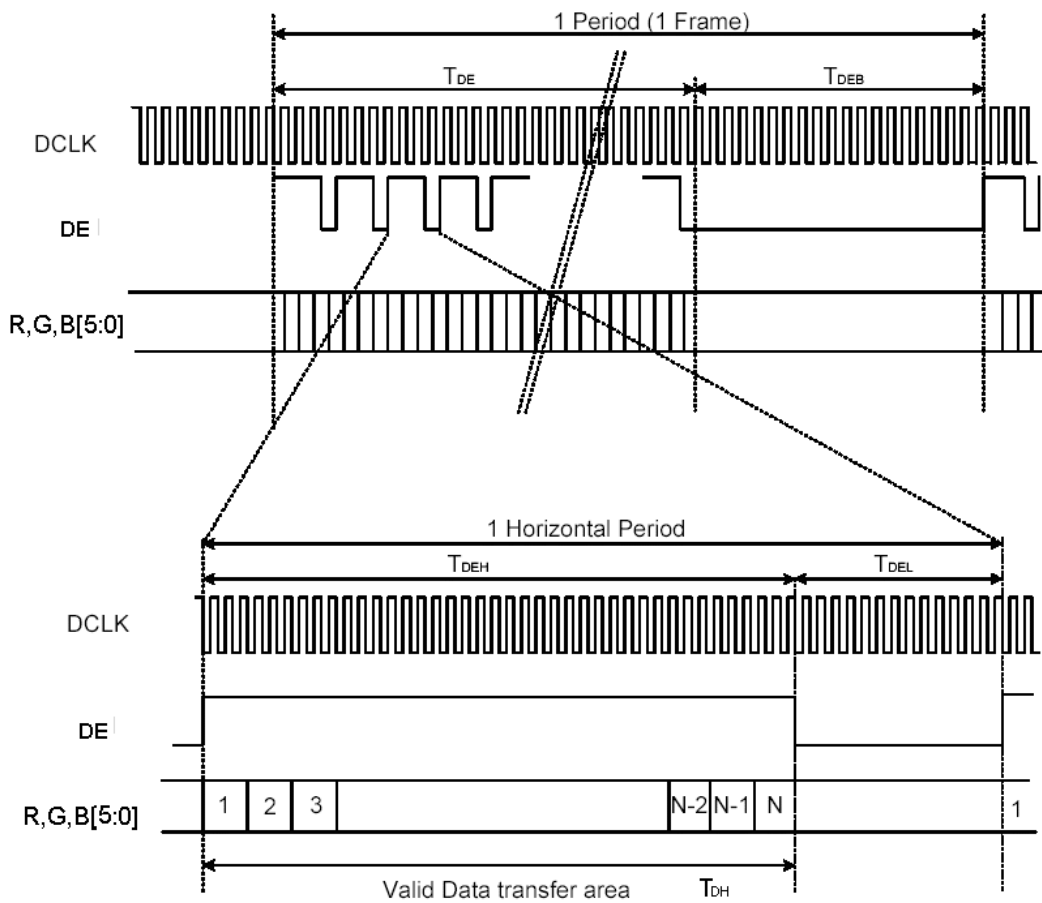

Figure 1 Clock and Data input waveforms.



**N=800**

**Figure 2 DE Mode Data Format**

### 6.3 Color Data Input Assignment

		Data Signal																	
		Red						Green						Blue					
Color		R5	R4	R3	R2	R1	R0	G5	G4	G3	G2	G1	G0	B5	B4	B3	B2	B1	B0
Basic Colors	Black	0	0	0	0	0	0	0	0	0	0	0	0	0	0	0	0	0	0
	Red	1	1	1	1	1	1	0	0	0	0	0	0	0	0	0	0	0	0
	Green	0	0	0	0	0	0	1	1	1	1	1	1	0	0	0	0	0	0
	Blue	0	0	0	0	0	0	0	0	0	0	0	0	1	1	1	1	1	1
	Cyan	0	0	0	0	0	0	1	1	1	1	1	1	1	1	1	1	1	1
	Magenta	1	1	1	1	1	1	0	0	0	0	0	0	1	1	1	1	1	1
	Yellow	1	1	1	1	1	1	1	1	1	1	1	1	0	0	0	0	0	0
	White	1	1	1	1	1	1	1	1	1	1	1	1	1	1	1	1	1	1
Gray Scale of Red	Red(0) / Dark	0	0	0	0	0	0	0	0	0	0	0	0	0	0	0	0	0	0
	Red(1)	0	0	0	0	0	1	0	0	0	0	0	0	0	0	0	0	0	0
	Red(2)	0	0	0	0	1	0	0	0	0	0	0	0	0	0	0	0	0	0
	:	:	:	:	:	:	:	:	:	:	:	:	:	:	:	:	:	:	:
	:	:	:	:	:	:	:	:	:	:	:	:	:	:	:	:	:	:	:
	Red(61)	1	1	1	1	0	1	0	0	0	0	0	0	0	0	0	0	0	0
	Red(62)	1	1	1	1	1	0	0	0	0	0	0	0	0	0	0	0	0	0
	Red(63)	1	1	1	1	1	1	0	0	0	0	0	0	0	0	0	0	0	0
Gray Scale of Green	Green(0)/ Dark	0	0	0	0	0	0	0	0	0	0	0	0	0	0	0	0	0	0
	Green(1)	0	0	0	0	0	0	0	0	0	0	0	1	0	0	0	0	0	0
	Green(2)	0	0	0	0	0	0	0	0	0	0	1	0	0	0	0	0	0	0
	:	:	:	:	:	:	:	:	:	:	:	:	:	:	:	:	:	:	:
	:	:	:	:	:	:	:	:	:	:	:	:	:	:	:	:	:	:	:
	Green(61)	0	0	0	0	0	0	1	1	1	1	0	1	0	0	0	0	0	0
	Green(62)	0	0	0	0	0	0	1	1	1	1	1	0	0	0	0	0	0	0
	Green(63)	0	0	0	0	0	0	1	1	1	1	1	1	0	0	0	0	0	0
Gray Scale of Blue	Blue(0)/ Dark	0	0	0	0	0	0	0	0	0	0	0	0	0	0	0	0	0	0
	Blue (1)	0	0	0	0	0	0	0	0	0	0	0	0	0	0	0	0	0	1
	Blue (2)	0	0	0	0	0	0	0	0	0	0	0	0	0	0	0	0	1	0
	:	:	:	:	:	:	:	:	:	:	:	:	:	:	:	:	:	:	:
	:	:	:	:	:	:	:	:	:	:	:	:	:	:	:	:	:	:	:
	Blue (61)	0	0	0	0	0	0	0	0	0	0	0	0	1	1	1	1	0	1
	Blue (62)	0	0	0	0	0	0	0	0	0	0	0	0	1	1	1	1	1	0
	Blue (63)	0	0	0	0	0	0	0	0	0	0	0	0	1	1	1	1	1	1

### 6.4 Pixel Format Image

Following figure shows the relationship of the input signals and LCD pixel format :

		1						2						...						799						800					
1st Line		R	G	B	R	G	B	.....						R	G	B	R	G	B	.....						R	G	B	R	G	B
	:	:						:						:						:						:					
	:	:						:						:						:						:					
	:	:						:						:						:						:					
	:	:						:						:						:						:					
	:	:						:						:						:						:					
	:	:						:						:						:						:					
600th Line		R	G	B	R	G	B	.....						R	G	B	R	G	B	.....						R	G	B	R	G	B

## 7. OPTICAL CHARACTERISTIC

### 7-1. Specification:

Parameter	Symbol	Condition	MIN.	TYP.	MAX.	Unit	Remarks	
Viewing Angle	Horizontal	$\theta_{x+}$	55	65	--	deg	Note 1,4	
		$\theta_{x-}$	55	65	--			
	Vertical	$\theta_{y+}$	CR $\geq$ 10	45	55			--
		$\theta_{y-}$		55	65			--
Contrast Ratio	CR max.	Center	250	350	--		Note 1,3	
Response time	Rise	Tr	-	15	--	ms	Note 1,6	
	Fall	Tf	$\theta_x=\theta_y=0^\circ$		--	ms		
Brightness Uniformity	B-uni	$\theta_x=\theta_y=0^\circ$	70	75	--	%	Note1,5	
Central Luminance	L	$I_L=200\text{mA}$	190	240	--	cd/m <sup>2</sup>	Note 1,2	
White Chromaticity	$x_w$	Center	0.26	0.31	0.36		Note 1,2	
	$y_w$	$\theta_x=\theta_y=0^\circ$	0.28	0.33	0.38			
Image sticking	tis	2 hours			2	Sec	Note 7	

The following optical specifications shall be measured in a darkroom or equivalent state (ambient luminance $\leq$ 1 lux, and at room temperature). The operation temperature is 25°C $\pm$ 2°C, and LED Current  $I_L=200\text{mA}$ . The measurement method is shown in Note1.

Note1: The method of optical measurement:

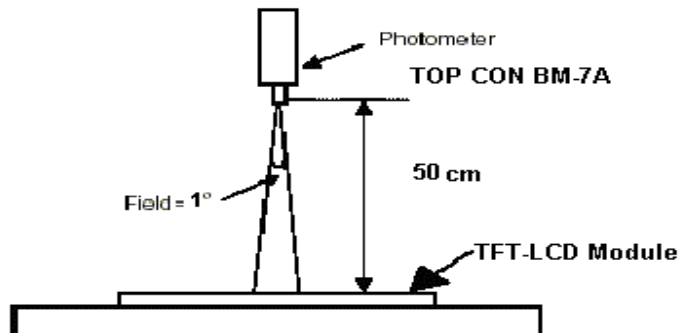

Note2: Measured at the central point of the LCD module and at the viewing angle of the  $\theta_x=\theta_y=0^\circ$

Note3: Definition of Contrast Ratio (CR):

$$CR = \frac{\text{Luminance with all pixels in white state}}{\text{Luminance with all pixels in Black state}}$$



Note 4: Definition of Viewing Angle(CR≥10):

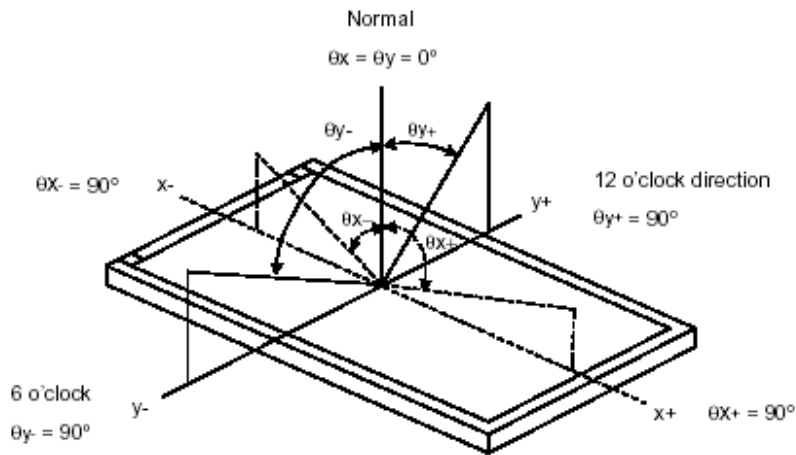

Note 5: Definition of Brightness Uniformity (B-uni):

### Luminance Measuring Points

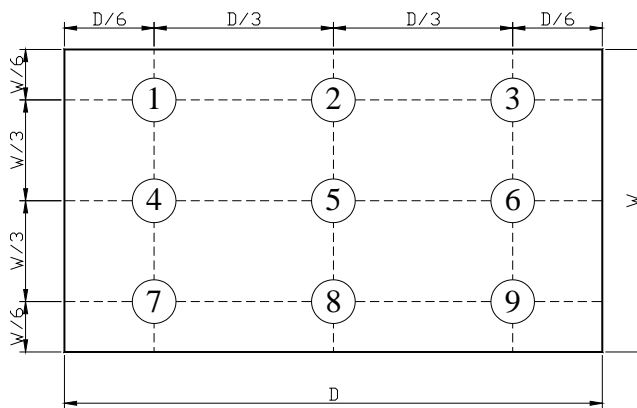

$$B\text{-uni} = \frac{\text{Minimum luminance of 9 points}}{\text{Maximum luminance of 9 points}}$$

Note6: Definition of Response Time:

The Response Time is set initially by defining the "Rising Time (Tr)" and the "Falling Time (Tf)" respectively. Tr and Tf are defined as following figure.

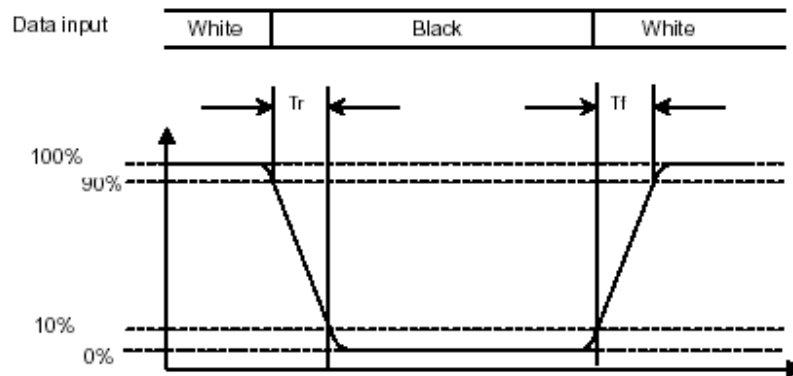

Note 7: Definition of Image sticking (tis):

Continuously display the test pattern shown in the figure below for 2 hours. Then display a completely white screen. The previous image shall not persist more than 2 sec at 25 °C

**Image sticking pattern**

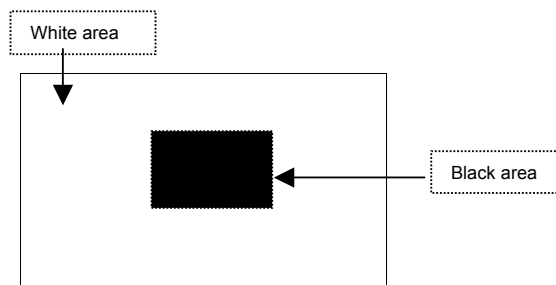

## 8. PIN CONNECTIONS

### 8.1 TFT LCD Panel Driving Section

Pin	Name	Description	Remark
1	VCC	Power Supply	
2	VCC	Power Supply	
3	GND	Ground	
4	GND	Ground	
5	RXIN0-	Differential Data Input, CH0 ( Negative )	R0 ~ R5, G0
6	RXIN0+	Differential Data Input, CH0 ( Positive )	
7	GND	Ground	
8	RXIN 1-	Differential Data Input, CH1 ( Negative )	G1 ~ G5, B0, B1
9	RXIN 1+	Differential Data Input , CH1 ( Positive )	
10	GND	Ground	
11	RXIN 2-	Differential Data Input , CH2 ( Negative )	B2 ~ B5, NC, NC,DE
12	RXIN 2+	Differential Data Input , CH2 ( Positive )	
13	GND	Ground	
14	CKIN-	Differential Clock Input ( Negative )	DCLK
15	CKIN+	Differential Clock Input ( Positive )	
16	GND	Ground	
17	NC	No Connection	
18	NC	No Connection	
19	GND	Ground	
20	GND	Ground	

### 8.2 Backlight Unit Section

Pin No.	Symbol	I/O	Function	Remark
1	A	P	Power supply for backlight unit	Pink
2	K	P	Ground for backlight unit	White

### 8.3 Power Signal Sequence

$t1 \leq 10\text{ms}$  :  $1 \text{ sec} \leq t5$

$50\text{ms} \leq t2$  :  $200\text{ms} \leq t6$

$0 < t3 \leq 50\text{ms}$ :  $200\text{ms} \leq t7$

$0 < t4 \leq 10\text{ms}$

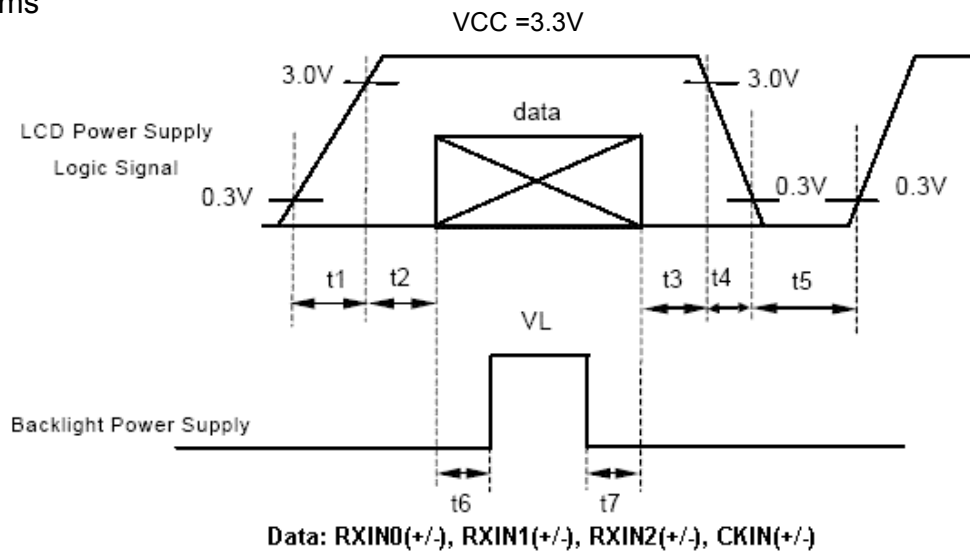

### 9. BLOCK DIAGRAM

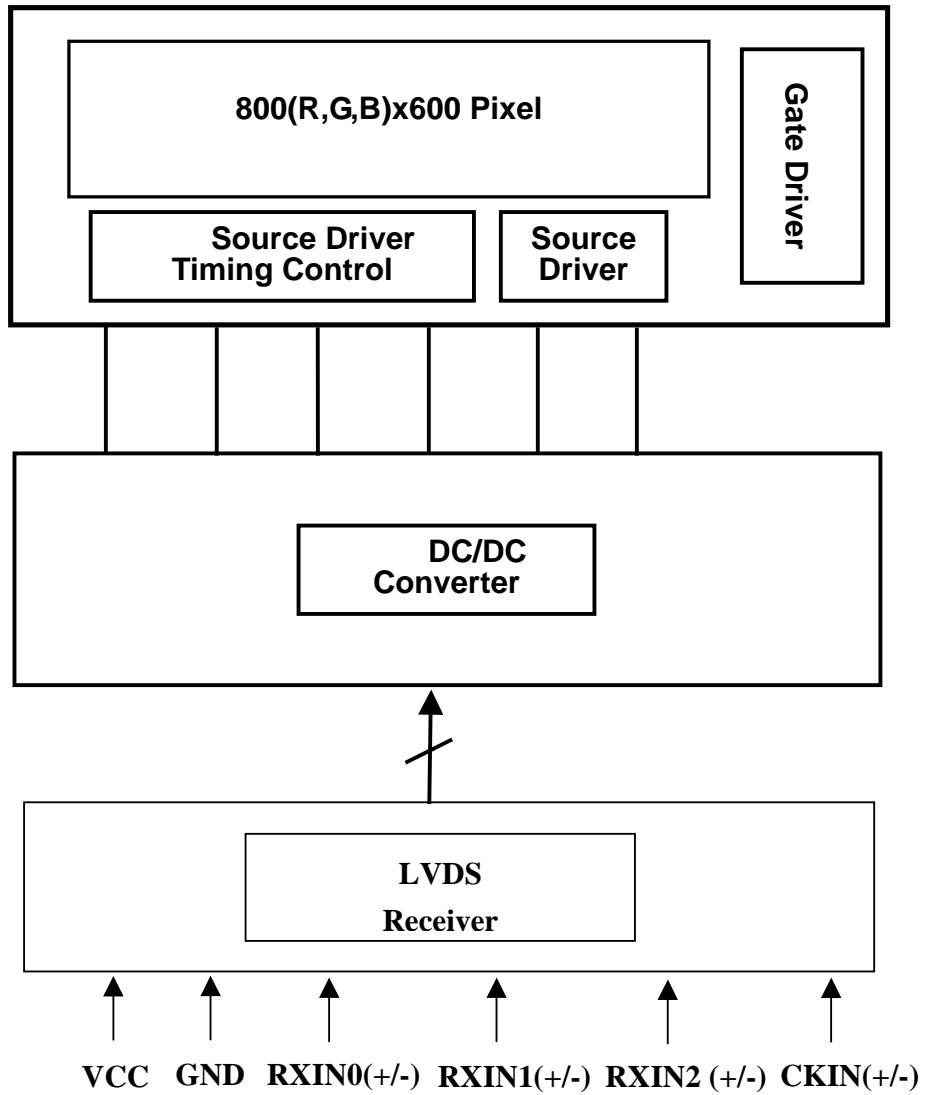

## 10. TOUCH PANEL CHARACTERISTICS

### 1. Input Method and Activation Force

Input Method	Average Activation Force
1.6mm dia. Delrin stylus	50gf Max.
16mm dia. Silicon "finger"	50gf Max.

### 2. Typical Optical Characteristics

ITEM	Parameter
Visible Light Transmission	82% typ.
Haze	5% typ.

### 3. Electrical Specification

ITEM	Parameter
Operating Voltage	DC 7V Max.
Circuit close resistance	X 300~1100Ω
	Y 150~650Ω
Circuit open resistance	≥20MΩ at 25V DC
Contact bounce	≤10ms
Linear Test	≤1.5%

### 4. Linearity

ITEM	Parameter
Linear Test Specification Direction	X ≤1.5%
	Y ≤1.5%

### 5. Specification

ITEM	Parameter
Operating Temperature	-10°C~+60°C
Storage Temperature	-30°C~+70°C

### 6. Durability test:

#### 6.1 Finger touches

Touch panel is hit 1 millions times with a silicone rubber of R8 finger, hitting rate is by 200g at 2 times per second. The measurement must satisfy the following:

- Circuit close resistance: x 300~1100Ω ; y 150~650Ω
- Circuit open resistance: ≥20MΩ at 25V DC
- Contact bounce: ≤10ms
- Linearity test: ≤3%

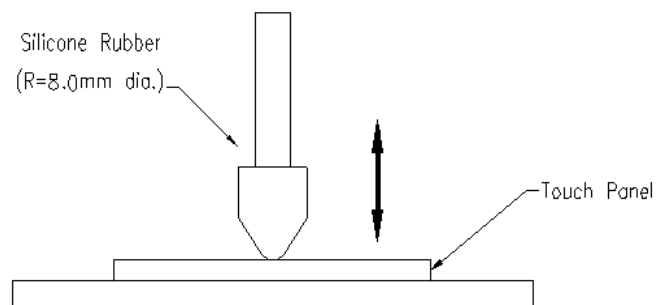

#### 6.2 Stylus writing

Touch panel is drawn by R0.8 Delrin stylus pen, at 250g forces, repeat one inch by 100k times. The measurement must satisfy the following:

- Circuit close resistance: x 300~1100Ω ; y 150~650Ω
- Circuit open resistance: ≥20MΩ at 25V DC
- Contact bounce: ≤10ms
- Linearity test: ≤3%

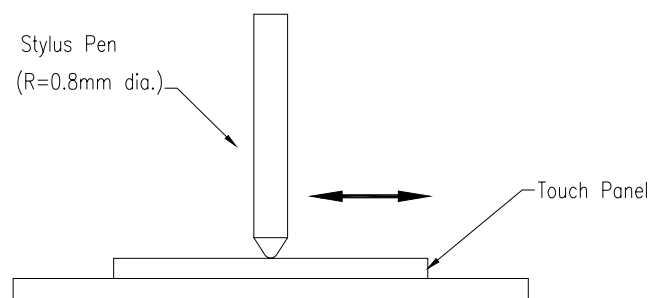

## 11. QUALITY ASSURANCE

### 11.1 Test Condition

#### 11.1.1 Temperature and Humidity(Ambient Temperature)

Temperature :  $25 \pm 5^{\circ}\text{C}$

Humidity :  $65 \pm 5\%$

#### 11.1.2 Operation

Unless specified otherwise, test will be conducted under function state.

#### 11.1.3 Container

Unless specified otherwise, vibration test will be conducted to the product itself without putting it in a container.

#### 11.1.4 Test Frequency

In case of related to deterioration such as shock test. It will be conducted only once.

#### 11.1.5 Test Method

Reliability Test Item & Level		Test Level
No.	Test Item	
1	High Temperature Storage Test	T=70 ,240hrs
2	Low Temperature Storage Test	T=-30 ,240hrs
3	High Temperature Operation Test	T=60 ,240hrs
4	Low Temperature Operation Test	T=-10 ,240hrs
5	High Temperature and High Humidity Operation Test	T=40 ,90%RH,240hrs
6	Thermal Cycling Test (No operation)	-30 → +25 → +70 ,100 Cycles 30 min 5 min 30 min
7	Vibration Test (No operation)	Frequency : 10 ~ 55 Hz Amplitude : 1.5 mm Sweep Time : 11mins Test Period : 6 cycles for each Direction of X,Y,Z
8	Shock Test (No operation)	100G, 6ms Direction : $\pm X, \pm Y, \pm Z$ Cycle : 3 times

## 12. LOT NUMBERING SYSTEM

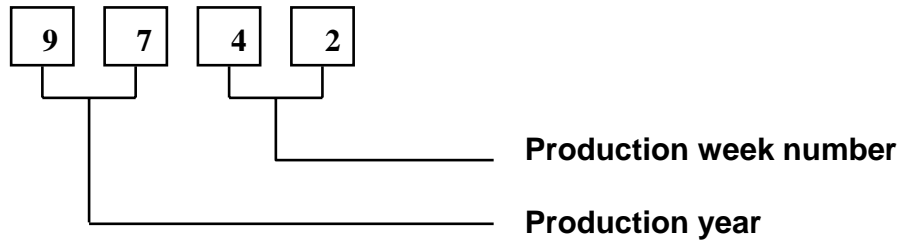

## 13. LCM NUMBERING SYSTEM

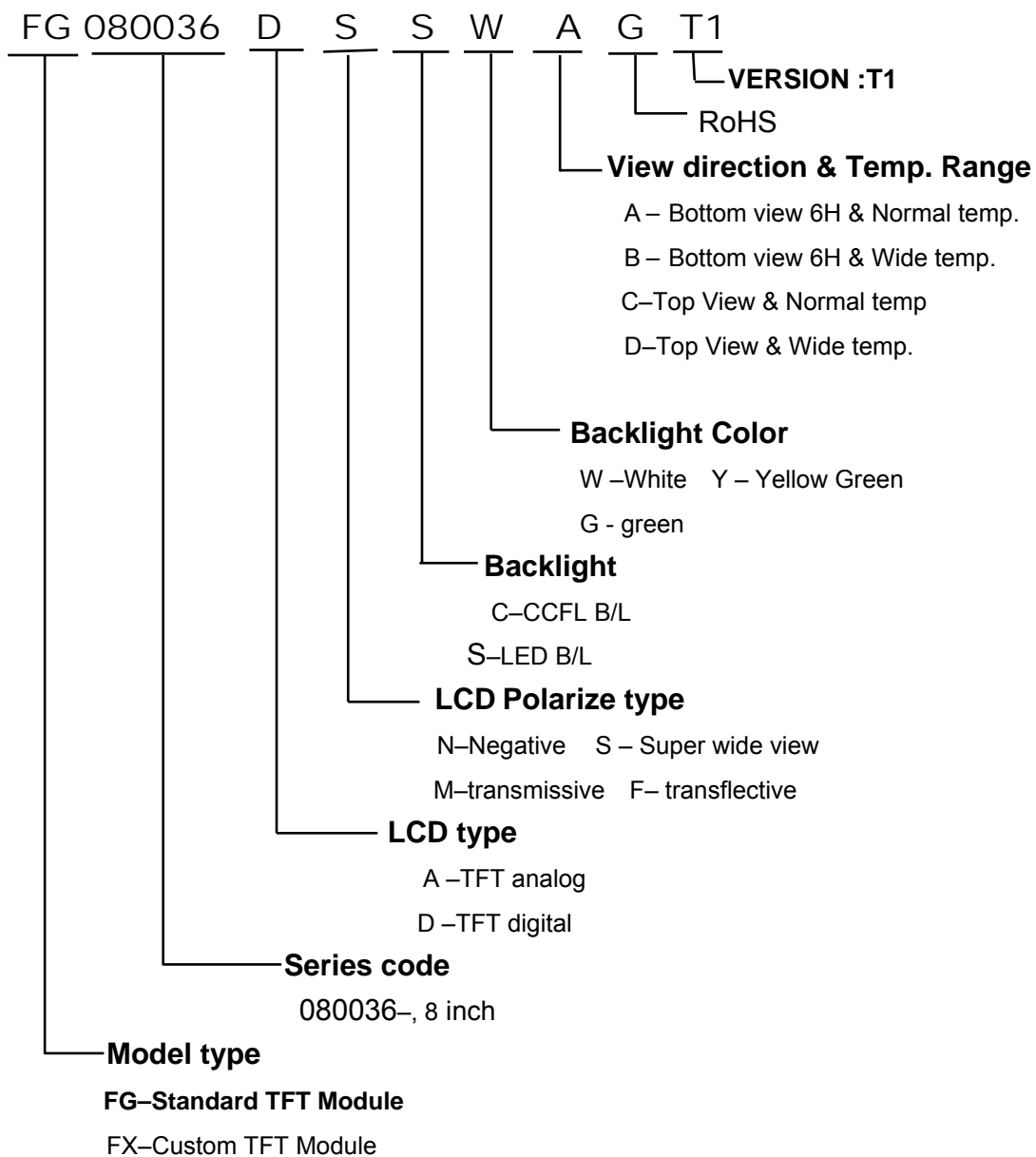



## 14. PRECAUTIONS IN USE LCM

### 1. LIQUID CRYSTAL DISPLAY (LCD)

LCD is made up of glass, organic sealant, organic fluid, and polymer based polarizers. The following precautions should be taken when handling,

- (1). Keep the temperature within range of use and storage. Excessive temperature and humidity could cause polarization degradation, polarizer peel off or bubble.
- (2). Do not contact the exposed polarizers with anything harder than an HB pencil lead. To clean dust off the display surface, wipe gently with cotton, chamois or other soft material soaked in petroleum benzin.
- (3). Wipe off saliva or water drops immediately. Contact with water over a long period of time may cause polarizer deformation or color fading, while an active LCD with water condensation on its surface will cause corrosion of ITO electrodes.
- (4). Glass can be easily chipped or cracked from rough handling, especially at corners and edges.
- (5). Do not drive LCD with DC voltage.

### 2. Liquid Crystal Display Modules

#### 2.1 Mechanical Considerations

LCM are assembled and adjusted with a high degree of precision. Avoid excessive shocks and do not make any alterations or modifications. The following should be noted.

- (1). Do not tamper in any way with the tabs on the metal frame.
- (2). Do not modify the PCB by drilling extra holes, changing its outline, moving its components or modifying its pattern.
- (3). Do not touch the elastomer connector, especially insert an backlight panel (for example, EL).
- (4). When mounting a LCM make sure that the PCB is not under any stress such as bending or twisting. Elastomer contacts are very delicate and missing pixels could result from slight dislocation of any of the elements.
- (5). Avoid pressing on the metal bezel, otherwise the elastomer connector could be deformed and lose contact, resulting in missing pixels.

#### 2.2. Static Electricity

LCM contains CMOS LSI's and the same precaution for such devices should apply, namely

- (1). The operator should be grounded whenever he/she comes into contact with the module. Never touch any of the conductive parts such as the LSI pads, the copper leads on the PCB and the interface terminals with any parts of the human body.
- (2). The modules should be kept in antistatic bags or other containers resistant to static for storage.
- (3). Only properly grounded soldering irons should be used.
- (4). If an electric screwdriver is used, it should be well grounded and shielded from commutator sparks.

- (5) The normal static prevention measures should be observed for work clothes and working benches; for the latter conductive (rubber) mat is recommended.
- (6). Since dry air is inductive to statics, a relative humidity of 50-60% is recommended.

#### 2.3 Soldering

- (1). Solder only to the I/O terminals.
- (2). Use only soldering irons with proper grounding and no leakage.
- (3). Soldering temperature :  $280^{\circ}\text{C} \pm 10^{\circ}\text{C}$
- (4). Soldering time: 3 to 4 sec.
- (5). Use eutectic solder with resin flux fill.
- (6). If flux is used, the LCD surface should be covered to avoid flux spatters. Flux residue should be removed after wards.

#### 2.4 Operation

- (1). Driving voltage should be kept within specified range; excess voltage shortens display life.
- (2). Response time increases with decrease in temperature.
- (3). Display may turn black or dark blue at temperatures above its operational range; this is (however not pressing on the viewing area) may cause the segments to appear "fractured".
- (4). Mechanical disturbance during operation (such as pressing on the viewing area) may cause the segments to appear "fractured".

#### 2.5 Storage

If any fluid leaks out of a damaged glass cell, wash off any human part that comes into contact with soap and water. Never swallow the fluid. The toxicity is extremely low but caution should be exercised at all the time.

Confidential Document  
**15. OUTLINE DRAWING**

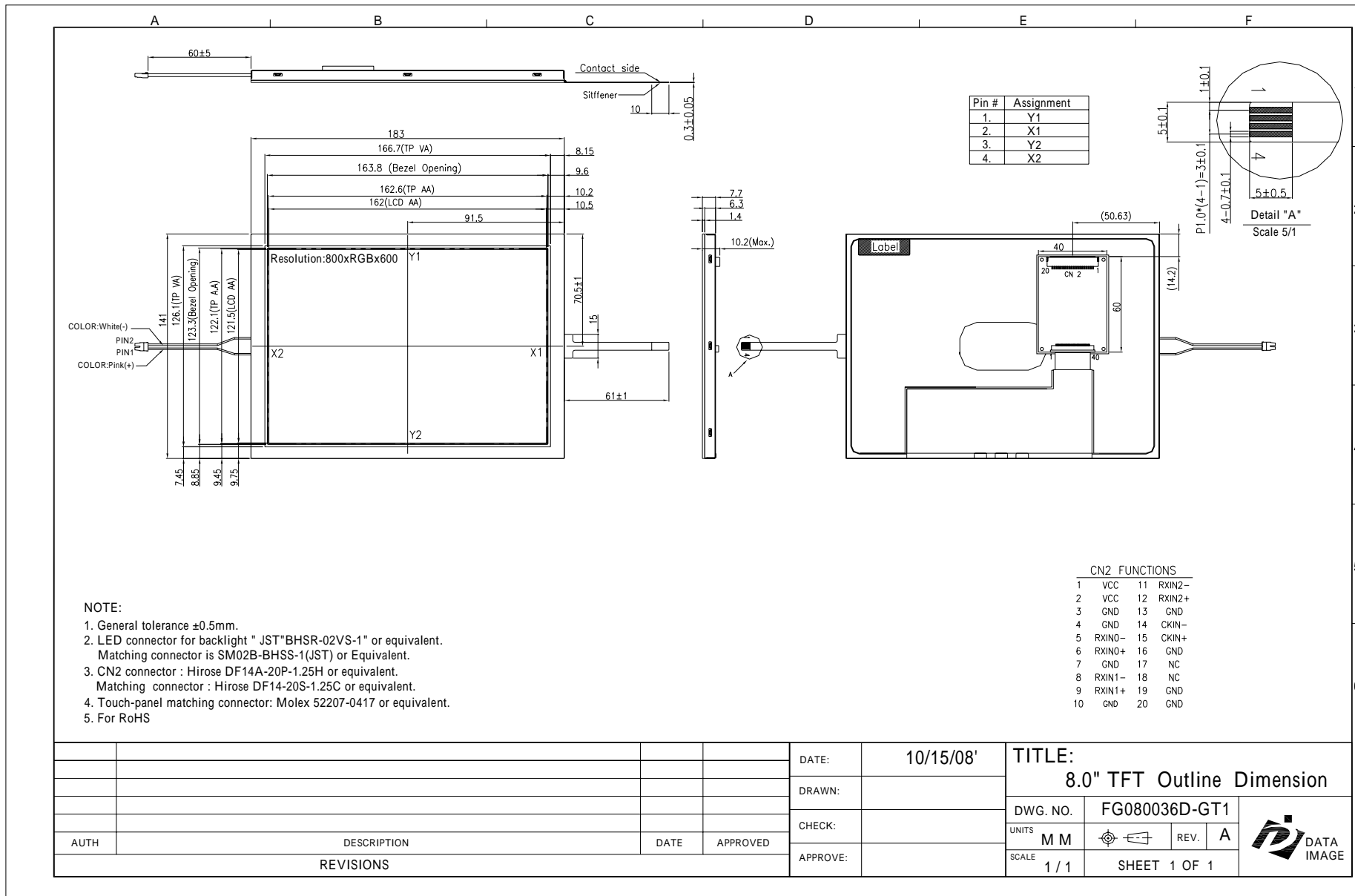

## 16. PACKAGE INFORMATION

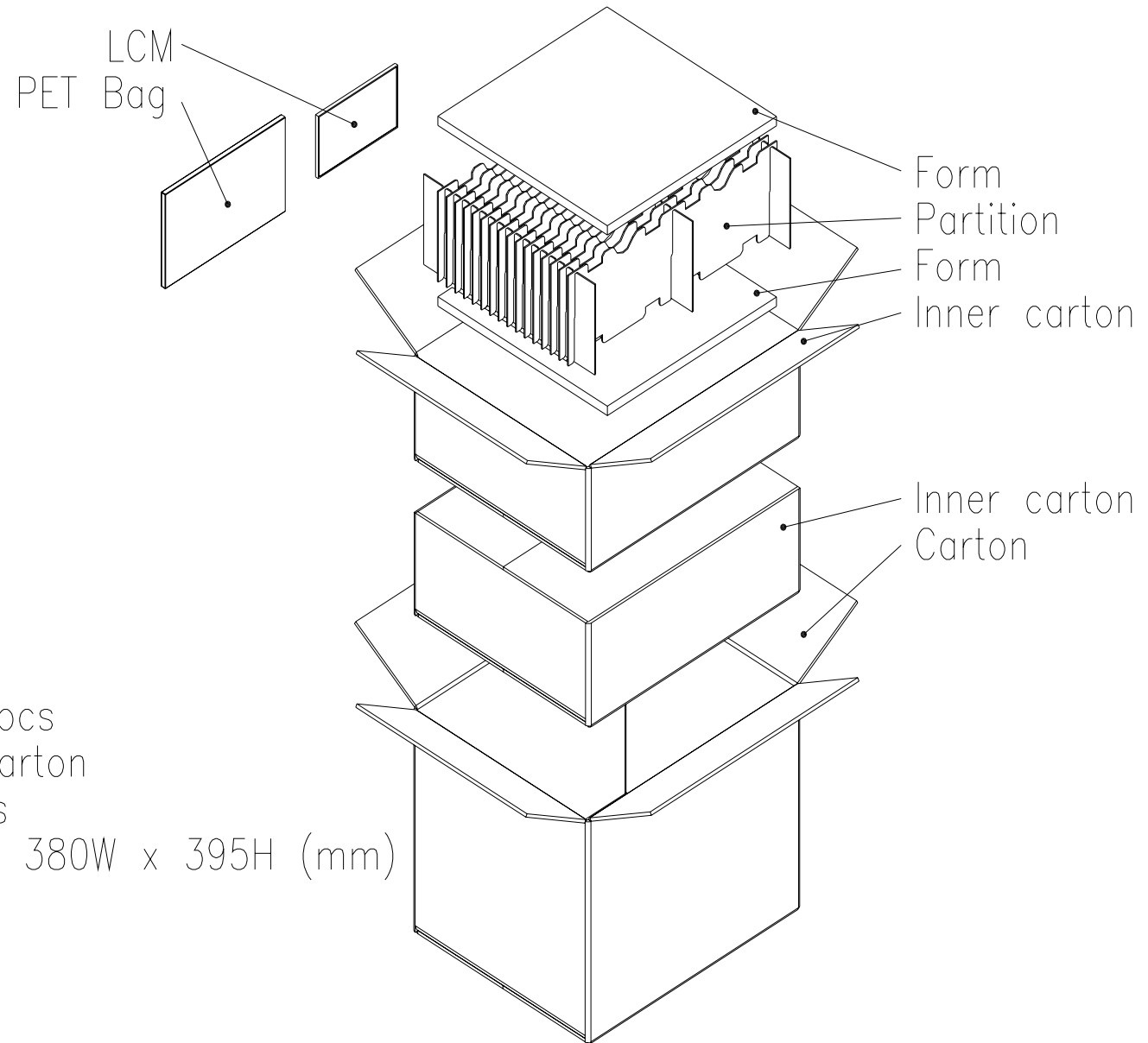

1 Inner carton= 30 pcs  
1 Carton= 2 Inner carton  
= 30 pcs\*2= 60 pcs  
Carton size : 465L x 380W x 395H (mm)