

QVGA-TFT-PCAP-Modul Datenblatt

Modell SCF0507827GGU02

Kurzdaten

Hersteller	Data Image
Diagonale	5,7" / 14,5 cm
Format	4:3
Auflösung	320 x 240
Backlight	LED / 415 cd/m ²
Interface	RGB
Touchscreen	ja
Temperatur	-10... +60°C (Betrieb)



Vertrieb durch:



Inselkammerstr. 10
82008 Unterhaching
Tel: +49 89 614 503 40
www.hy-line.de/computer

Confidential Document

DATA IMAGE CORPORATION

CTP Module Specification Preliminary

ITEM NO.: SCF0507827GGU02

Table of Contents

1. COVER & CONTENTS	1
2. RECORD OF REVISION	2
3. APPLICATION.....	3
4. GENERAL SPECIFICATIONS	3
5. ABSOLUTE MAXIMUM RATINGS	3
6. ELECTRICAL CHARACTERISTICS	3
7. INPUT SIGNAL CHARACTERISTICS	4
8. OPTICAL CHARACTERISTIC	9
9. PIN CONNECTIONS	12
10. BLOCK DIAGRAM	13
11. CTP GENERAL SPECIFICATIONS	14
12. APPEARANCE SPECIFICATION	21
13. QUALITY ASSURANCE	24
14. LCM PRODUCT LABEL DEFINE	25
15. PRECAUTIONS IN USE LCM	27
16. OUTLINE DRAWING	28
17. PACKAGE INFORMATION.....	29

Customer Companies	R&D Dept.	Q.C. Dept.	Eng. Dept.	Prod. Dept.
	JACK	JOE	GARY	KEN
Approved by	Version:	Issued Date:	Sheet Code:	Total Pages:
	2	15/JUL/12'		29

3. APPLICATION

DVD player, Car TV, UMPC, POS

4. GENERAL SPECIFICATIONS

Parameter	Specifications	Unit
Screen Size	5.7 (diagonal)	inch
Display Format	320(H) x (R,G,B) x 240(V)	dot
LCD Active Area	115.2(W) x 86.4(H) mm	mm
Dot Pitch	0.12W) x 0.36(H) mm	mm
Pixel Configuration	R.G.B. Stripe	
Outline Dimension	142.75(W) x 113.95(H) x 10.9 (D)	mm
Surface treatment	Clear	
Back-light	LED	
Display mode	Normally white	
Weight	T.B.D(typ)	g
View Angle direction	6 o'clock	

5. ABSOLUTE MAXIMUM RATINGS

Parameter	Symbol	MIN.	MAX.	Unit	Remark
Power supply voltage	V _{cc}	-0.3	5.0	V	
Logic input voltage	V _I	-0.3	V _{cc} +0.3	V	
Operating temperature	Top	-10	+60	°C	Ambient temperature
Storage temperature	T _{st}	-20	+70	°C	Ambient temperature

6. ELECTRICAL CHARACTERISTICS

GND=0V,CLK1=7.21MHz,Ta=25°C

Parameter	Symbol	MIN.	Typ.	MAX.	Unit	Remark
Power Supply voltage for LCD	V _{CC}	+3.0	+3.3	+3.6	V	
Power Supply Current for LCD	I _{CC}		62	80	mA	V _{CC} =3.3V
Power Supply voltage for LED	V _{LED}	4.5	5	5.5	V	
Power Supply Current for LED	I _{LED}		333	400	mA	V _{LED} =5.0V
Ripple voltage	V _{RF}	-	-	100	mV _{P-P}	
"H" level logical input voltage	V _{IH}	0.7V _{cc}	--	V _{cc}	V	
"L" level logical input voltage	V _{IL}	0	--	0.3V _{cc}	V	
ADJ frequency		19K	20K	21K	Hz	
ADJ input voltage	V _{IH}	3.0	-	3.3	V	
	V _{IL}	0	-	0.3	V	
LED Dice life time		-	50000	-	Hr	Note 1

Note 1: The "LED dice life time" is defined as the brightness decrease to 50% original brightness that the ambient temperature is 22 and LED dice current=20mA.

7. INPUT SIGNAL CHARACTERISTICS

7.1 Input Signal Timing Specifications

Parameter		Symbol	MIN.	TYP.	MAX.	Unit	Remarks
CLK	Frequency	1/Tc		7.21		MHz	
	Duty ratio	Th/Tc	40	50	60	%	
DATA	Setup time	Tds	12			ns	
	Hold time	Tdh	12			ns	
Horizontal synchronizing	Period	TH	--	453	--	Clock	
	Pulse width	THp	--	31	--	Clock	
	Horizontal period	THd	--	320	--	Clock	
	Back porch	THb	--	69	--	Clock	
	Front porch	THf	--	33	--	Clock	
Vertical synchronizing	Period	TV	--	267	--	Line	
	Pulse width	TVp	--	6	--	Line	
	Vertical period	TVd	--	240	--	Line	
	Back porch	TVb	--	18	--	Line	
	Front porch	TVf	--	3	--	Line	

Note:

- ◇ In case of using the slow frequency, the deterioration of display flicker etc may occur.
- ◇ The timing characteristics are basically fixed as above.

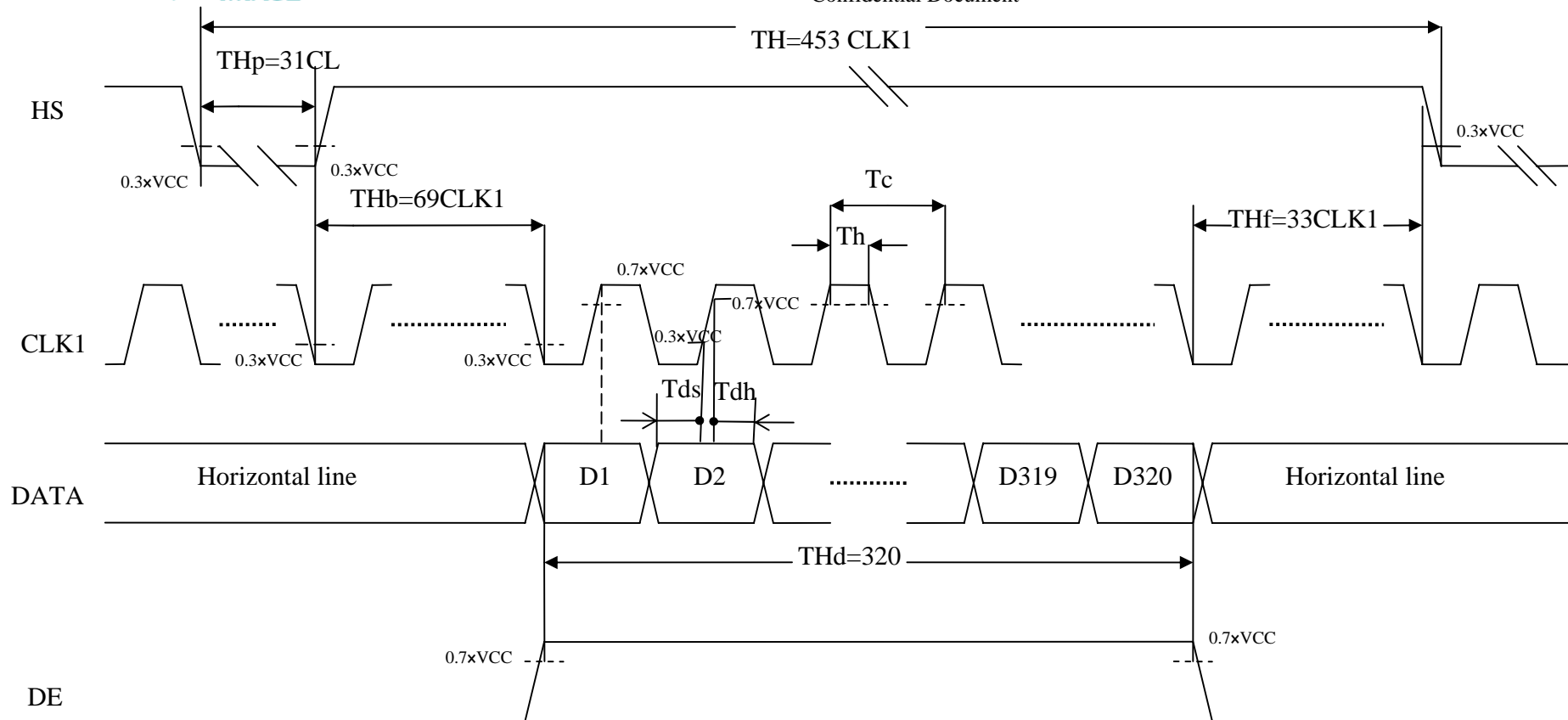

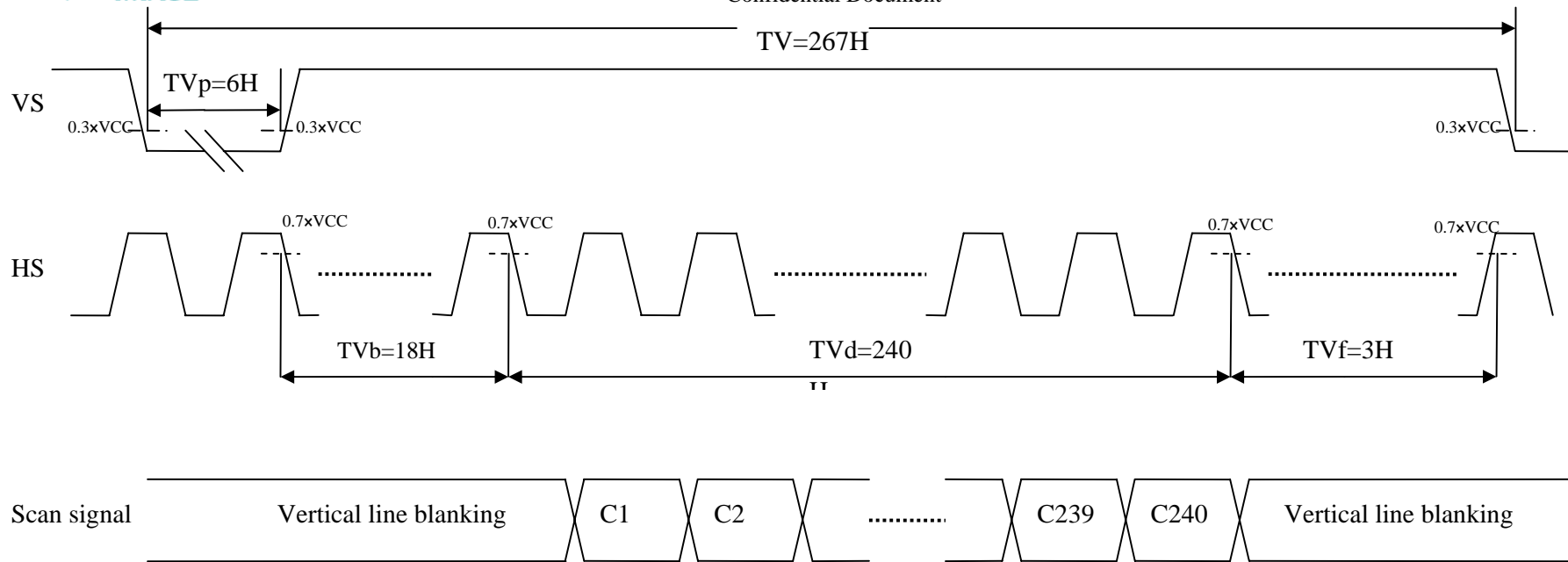

7.2 SYNC mode timing (DE connect to GND)

Parameter		Symbol	MIN.	TYP.	MAX.	Unit	Remarks
CLK	Frequency	1/Tc		6.41		MHz	
	Duty ratio	Th/Tc	40	50	60	%	
DATA	Setup time	Tds	12			ns	
	Hold time	Tdh	12			ns	
Horizontal synchronizing	Period	TH	--	408	--	Clock	
	Pulse width	THp	--	30	--	Clock	
	Horizontal period	THd	--	320	--	Clock	
	Back porch	THb	--	38	--	Clock	
	Front porch	THf	--	20	--	Clock	
Vertical synchronizing	Period	TV	--	262	--	Line	
	Pulse width	TVp	--	4	--	Line	
	Vertical period	TVd	--	240	--	Line	
	Back porch	TVb	--	15	--	Line	
	Front porch	TVf	--	3	--	Line	

Note:

- ✧ In case of using the slow frequency, the deterioration of display flicker etc may occur.
- ✧ The timing characteristics are basically fixed as above.

7.3 Power Off/On Sequence Timing

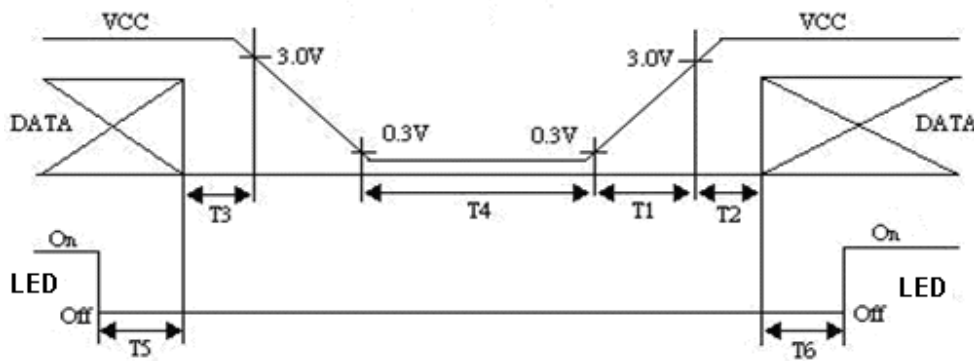

Timing Specifications:

- 0 < T1 ≤ 15mS
- T2 > 0.5S
- 0 < T3 ≤ 0.1S
- T4 > 1S
- T5 > 0.1S
- T6 > 0.1S

7.4 Color Data Input Assignment

		Data Signal																	
		Red					Green					Blue							
Color		R5	R4	R3	R2	R1	R0	G5	G4	G3	G2	G1	G0	B5	B4	B3	B2	B1	B0
Basic Colors	Black	0	0	0	0	0	0	0	0	0	0	0	0	0	0	0	0	0	0
	Red	1	1	1	1	1	1	0	0	0	0	0	0	0	0	0	0	0	0
	Green	0	0	0	0	0	0	1	1	1	1	1	1	0	0	0	0	0	0
	Blue	0	0	0	0	0	0	0	0	0	0	0	0	1	1	1	1	1	1
	Cyan	0	0	0	0	0	0	1	1	1	1	1	1	1	1	1	1	1	1
	Magenta	1	1	1	1	1	1	0	0	0	0	0	0	1	1	1	1	1	1
	Yellow	1	1	1	1	1	1	1	1	1	1	1	1	0	0	0	0	0	0
	White	1	1	1	1	1	1	1	1	1	1	1	1	1	1	1	1	1	1
Gray Scale of Red	Red(0) / Dark	0	0	0	0	0	0	0	0	0	0	0	0	0	0	0	0	0	0
	Red(1)	0	0	0	0	0	1	0	0	0	0	0	0	0	0	0	0	0	0
	Red(2)	0	0	0	0	1	0	0	0	0	0	0	0	0	0	0	0	0	0
	:	:	:	:	:	:	:	:	:	:	:	:	:	:	:	:	:	:	:
	:	:	:	:	:	:	:	:	:	:	:	:	:	:	:	:	:	:	:
	Red(61)	1	1	1	1	0	1	0	0	0	0	0	0	0	0	0	0	0	0
	Red(62)	1	1	1	1	1	0	0	0	0	0	0	0	0	0	0	0	0	0
	Red(63)	1	1	1	1	1	1	0	0	0	0	0	0	0	0	0	0	0	0
Gray Scale of Green	Green(0)/ Dark	0	0	0	0	0	0	0	0	0	0	0	0	0	0	0	0	0	0
	Green(1)	0	0	0	0	0	0	0	0	0	0	1	0	0	0	0	0	0	
	Green(2)	0	0	0	0	0	0	0	0	0	0	1	0	0	0	0	0	0	
	:	:	:	:	:	:	:	:	:	:	:	:	:	:	:	:	:	:	
	:	:	:	:	:	:	:	:	:	:	:	:	:	:	:	:	:	:	
	Green(61)	0	0	0	0	0	0	1	1	1	1	0	1	0	0	0	0	0	
	Green(62)	0	0	0	0	0	0	1	1	1	1	1	0	0	0	0	0	0	
	Green(63)	0	0	0	0	0	0	1	1	1	1	1	1	0	0	0	0	0	
Gray Scale of Blue	Blue(0)/ Dark	0	0	0	0	0	0	0	0	0	0	0	0	0	0	0	0	0	0
	Blue (1)	0	0	0	0	0	0	0	0	0	0	0	0	0	0	0	0	0	1
	Blue (2)	0	0	0	0	0	0	0	0	0	0	0	0	0	0	0	0	1	0
	:	:	:	:	:	:	:	:	:	:	:	:	:	:	:	:	:	:	:
	:	:	:	:	:	:	:	:	:	:	:	:	:	:	:	:	:	:	:
	Blue (61)	0	0	0	0	0	0	0	0	0	0	0	0	1	1	1	1	1	0
	Blue (62)	0	0	0	0	0	0	0	0	0	0	0	0	1	1	1	1	1	0
	Blue (63)	0	0	0	0	0	0	0	0	0	0	0	0	1	1	1	1	1	1

Correspondence between Data and Display Position

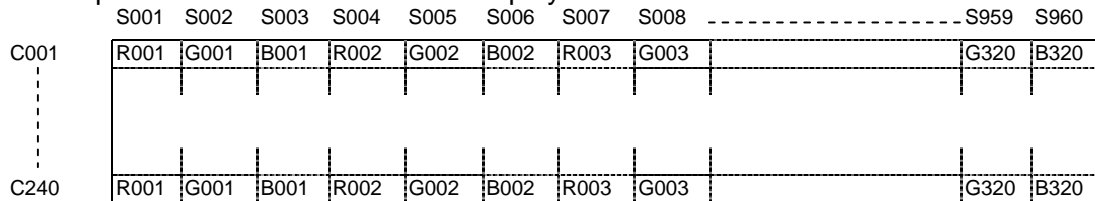

8. OPTICAL CHARACTERISTIC

Parameter	Symbol	Condition	MIN.	TYP.	MAX.	Unit	Remarks	
Viewing Angle	Horizontal	θ_{x+}	60	70	--	deg	Note 1,4	
		θ_{x-}	60	70	--			
	Vertical	θ_{y+}	40	50	--			
		θ_{y-}	60	70	--			
Contrast Ratio	CR	at optimized viewing angle	300	350			Note 1,3	
Response time	Rise	Tr	-	15	30	ms	Note 1,6	
	Fall	Tf	-	35	50	ms		
Uniformity		B-uni	$\theta_{x=\theta y = 0^\circ}$	70	80	--	%	Note1,5
Brightness		L	$\theta_{x=\theta y = 0^\circ}$ ADJ=3.3V	370	415	--	cd/m ²	Note 1,2
Chromaticity	x_W	Center $\theta_{x=\theta y = 0^\circ}$	0.262	0.312	0.362		Note 1,7	
	y_W		0.270	0.320	0.370			
	x_R		0.568	0.618	0.668			
	y_R		0.319	0.369	0.419			
	x_G		0.301	0.351	0.401			
	y_G		0.521	0.571	0.621			
	x_B		0.094	0.144	0.194			
	y_B		0.031	0.081	0.131			
Image sticking	tis	2 hours			2	Sec	Note 8	

The following optical specifications shall be measured in a darkroom or equivalent state (ambient luminance ≤ 1 lux, and at room temperature). The operation temperature is $25^\circ\text{C} \pm 2^\circ\text{C}$. The measurement method is shown in Note1.

Note1: The method of optical measurement:

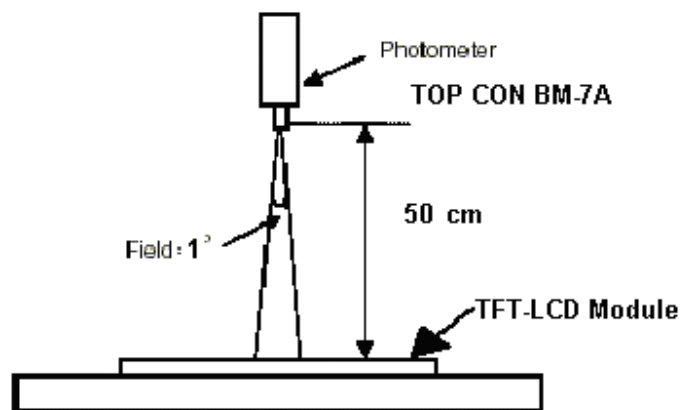

Note2: Measured at the center area of the panel and at the viewing angle of the $\theta_x = \theta_y = 0^\circ$

Note3: Definition of Contrast Ratio (CR):

$$CR = \frac{\text{Luminance with all pixels in white state}}{\text{Luminance with all pixels in Black state}}$$

Note4: Definition of Viewing Angle

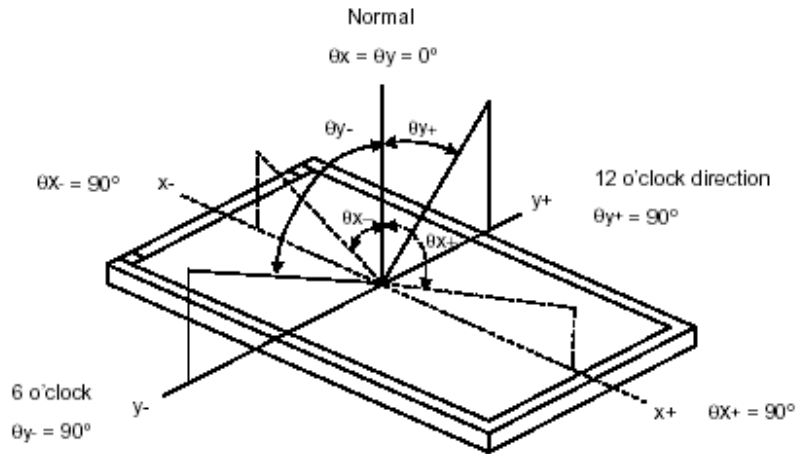

Note 5: Definition of Brightness Uniformity (B-uni):

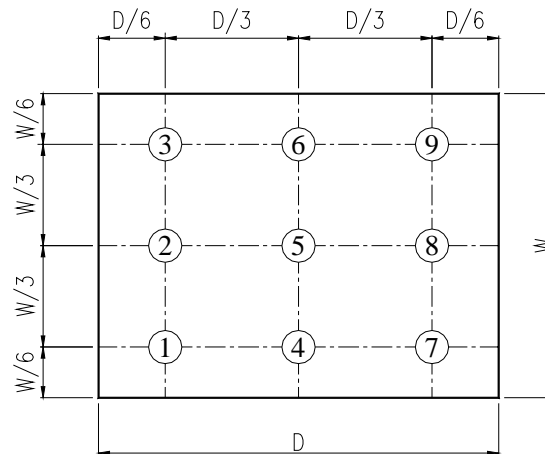

$$B\text{-uni} = \frac{\text{Minimum luminance of 9 points}}{\text{Maximum luminance of 9 points}} \quad (\text{Note 5}).$$

Note6: Definition of Response Time:

The Response Time is set initially by defining the "Rising Time (T_r)" and the "Falling Time (T_f)" respectively. T_r and T_f are defined as following figure.

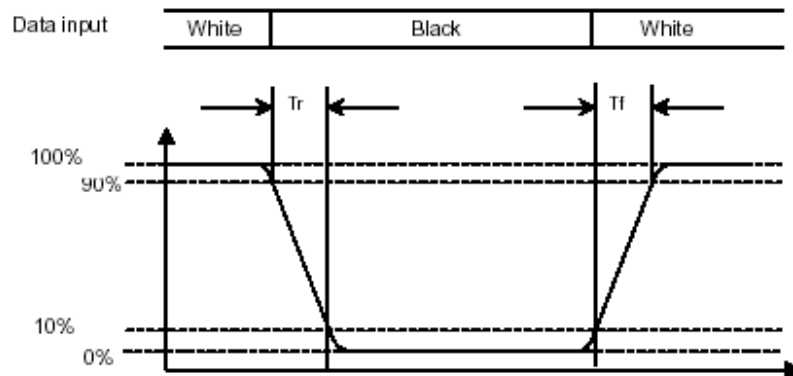

Note 7: Definition of Chromaticity:

The color coordinates (x_w, y_w) , (x_r, y_r) , (x_g, y_g) , and (x_b, y_b) are obtained with all pixels in the viewing field at white, red, green, and blue states, respectively.

Note 8: Definition of Image sticking (t_{is}):

Continuously display the test pattern shown in the figure below for 2 hours. Then display a completely white screen. The previous image shall not persist more than 2 sec at 25 °C

Image sticking pattern

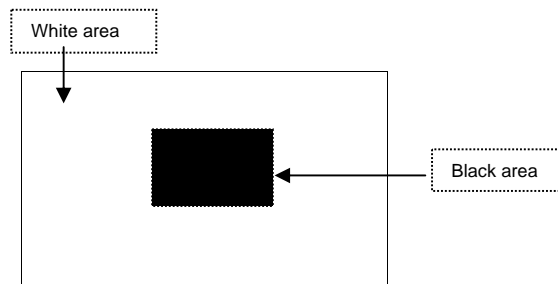

9. PIN CONNECTIONS

9.1 CN1 Pins Connections

Pin No	Symbol	Function	Remark
1	GND	Ground for logic circuit	
2	CLK1	Data sampling clock	
3	HS (HSYNC)	Horizontal synchronous signal	
4	VS (VSYNC)	Vertical synchronous signal	
5	GND	Ground	
6	R0	Red pixel data(LSB)	
7	R1	Red pixel data	
8	R2	Red pixel data	
9	R3	Red pixel data	
10	R4	Red pixel data	
11	R5	Red pixel data(MSB)	
12	GND	Ground	
13	G0	Green pixel data(LSB)	
14	G1	Green pixel data	
15	G2	Green pixel data	
16	G3	Green pixel data	
17	G4	Green pixel data	
18	G5	Green pixel data(MSB)	
19	GND	Ground	
20	B0	Blue pixel data(LSB)	
21	B1	Blue pixel data	
22	B2	Blue pixel data	
23	B3	Blue pixel data	
24	B4	Blue pixel data	
25	B5	Blue pixel data(MSB)	
26	GND	Ground for logic circuit	
27	DE	Data Enable (connected to GND, if sync mode)	
28	VCC	Power Supply : +3.3V	
29	VCC	Power Supply : +3.3V	
30	R/L	Horizontal display mode select signal Left / Right Scan control input	*2
31	U/D	Vertical display mode select signal Up / Down Scan control input	*2
32	NC	No Connection	
33	GND	Ground	

*1 The horizontal display start timing is settled in accordance with a rising timing of DE signal. In case DE is fixed "Low", the horizontal start timing is determined as described in 9.2. Don't keep DE "High" during operation.

*2 U/D and L/R control Function

L/R	U/D	Function
0	1	Normally display
1	1	Left and Right opposite
0	0	Up and Down opposite
1	0	Left and Right opposite , Up and Down opposite

9.2. CN2 Pins Connections

Pin No.	Symbol	Function	Remark
1	VLED	Power supply for LED driver circuit	
2	GND	Ground	
3	ADJ	Brightness control for LED B/L	

*ADJ is brightness control pin. The larger of the pulse duty is, higher of the brightness.

10. BLOCK DIAGRAM

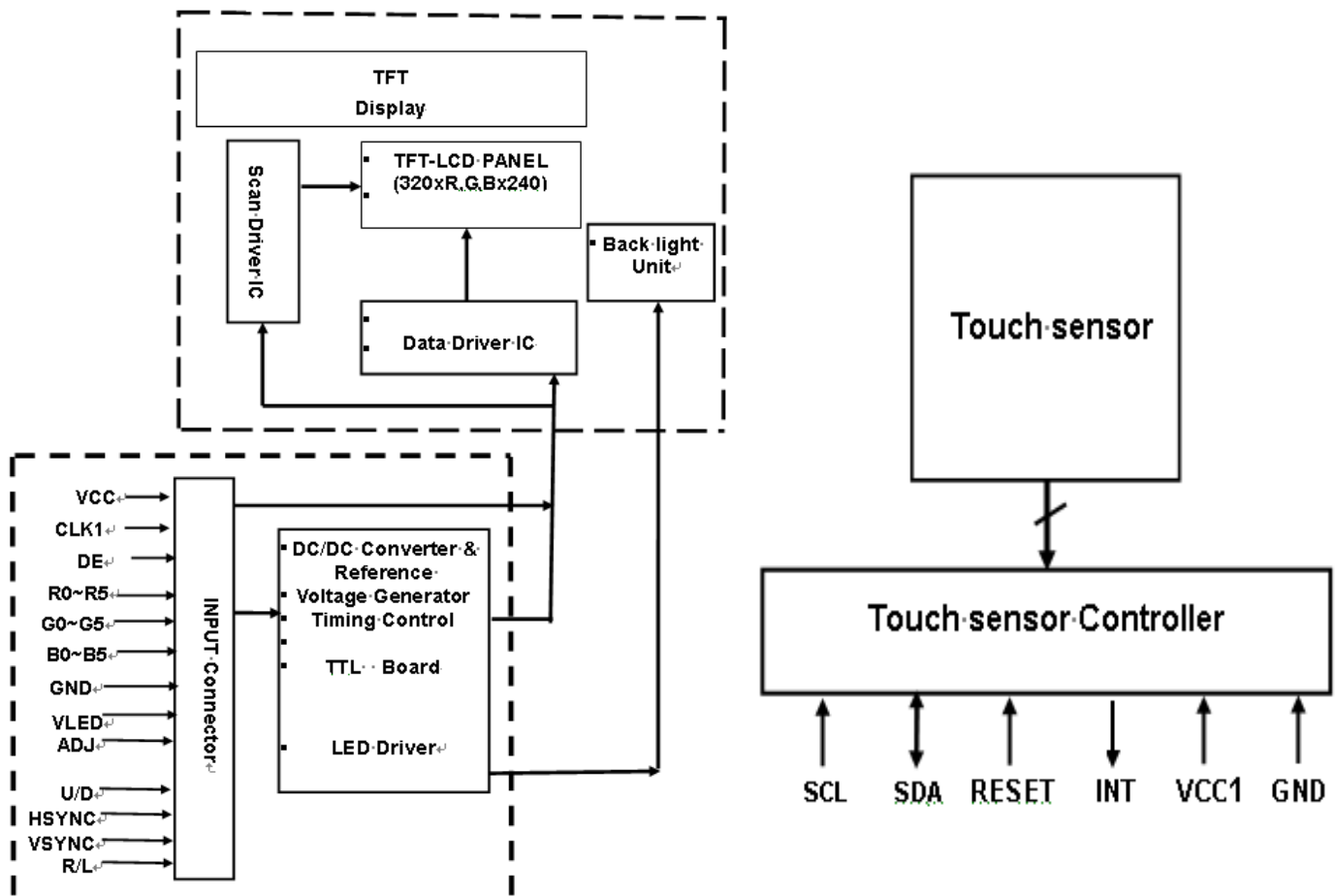

11. CTP General specifications

11.1 CTP main feature

Item	Specification	Unit
Type	Transparent type projected capacitive touch panel	
Input mode	Human's finger	
Finger	5	
Sensor Active Area	118.76(W)(typ.) x 89.95(H)(typ.)	mm
Transparency	85%	%
Haze	2.0%	%
Hardness	7H (typ.) [by JIS K5400]	Pencil hardness
Report rate	Max : 122	Points/sec
Response time	15	ms
Point hitting life time	1,000,000 times min.	Note 1

Note 1: Use 8 mm diameter silicon rubber/force 3N to knock on the same point twice per second (no-operating), after test function check pass.

central point

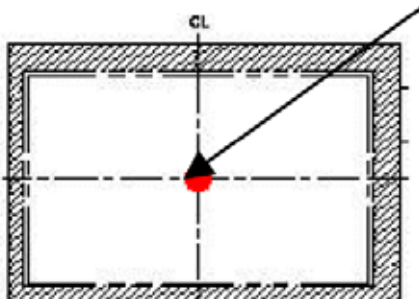

11.2 CTP Absolute Maximum Rating

Symbol	Description	Min	Typ.	Max	Unit	Notes
VCC1	Supply voltage	0.3	-	4	V	
VIO	DC input voltage	-0.3	-	VCC1+0.3	V	

11.3 CTP Electrical Characteristic

Symbol	Description	Min	Typ	Max	Unit	Notes
VCC1	Supply voltage	2.6	2.8	3.6	V	
GND	Supply voltage	-	0	-	V	
I	Active mode	-	10		mA	VCC1 = 2.8V
V _{IH}	Input H voltage	1.6	-	-	V	
V _{IL}	Input L voltage	-	-	0.7	V	
	System clock frequency	-	30	-	MHz	

11.4 CTP Pin Connections

No.	Name	I/O	Description
1	NC	-	No connection
2	SCL	I	I ² C Clock
3	SDA	I/O	I ² C Data
4	NC	-	No connection
5	INT	O	Interrupt output
6	GND	P	Ground
7	VCC1	P	Power supply Voltage
8	/RESET	I	Reset active low
9	NC	-	No connection

11.5 CTP Interface and Data Format [Slave address is 0x5D (7 bit addressing)]

Communication protocol: I²C

Clock frequency : 100Khz (400Khz Fast mode)

Below is timing of I2C hardware circuit:

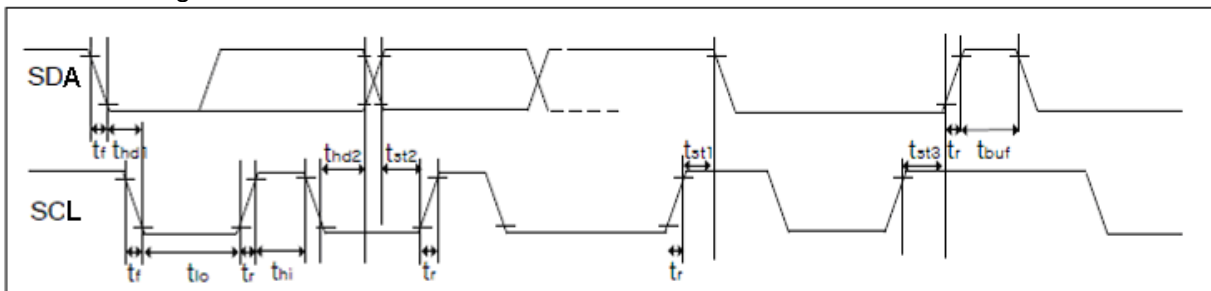

Parameter	Symbol	Min	Max	Unit
SCL frequency	f_{sck}	-	600	KHZ
SCL low period	t_{lo}	0.8	-	us
SCL high period	t_{hi}	0.5	-	us
SCL setup time for START condition	t_{st1}	0.4	-	us
SCL setup time for STOP condition	t_{st3}	0.4	-	us
SCL hold time for START condition	t_{st1}	0.4	-	us
SDA setup time	t_{st2}	0.5	-	us
SDA hold time	t_{st2}	0.2	-	us

11.6 Timing Characteristic

The address of GT827's slave device is 0xBA/0xBB. When master CPU addressing GT827, it will send read and write control bits simultaneously where are appended to slave device ("0"- write; "1"- read) for composing a byte with device address. i.e.: 0xBA – conduct write operation to GT827; 0xBB – conduct read operation to GT827.

11.6.1 Postfix Communication:

Only after receiving postfix signal (under the condition of no external signal), can GT827 update coordinate in buffer in real time. After completing communication, I2C needs to send extra postfix signal. But if a series of communication appear, the postfix signal should be sent after the last one finished (except the coordinate reading process, the postfix signal could be sent after finishing reading a frame, so as to prevent output buffer to be changed by GT827 during the read process of master device). Below is the communication format of postfix: Use write process to search register addressing (0x8000), and send stop signal.

11.6.2 Data Transmission:

The communication usually is launched by master CPU. When SCL keeps "1" SDA manages the change from "1" to "0". Then the address information or data stream begins to transmit after start signal.

Any slave device connected with I2C circuit needs to check 8 bits address information after circuit launches start signal and respond correctly. After receiving the matching address information, GT827 will update SDA as an output and set the value as "0" for answering signal in the ninth clock cycle. The GT827 will lay idle if matching address information is unavailable (neither 0xBA nor 0xBB).

The SDA port sends the data with 9 bits serial data according to nine clock cycles. The 8 valid data + 1 receiver send ACK (acknowledgement signal) or NACK (negative acknowledgement signal). It is valid when SCL is "1" during the data transmission.

The main CPU sends stop signal after transmission where SDA manages the change from "0" to "1" when SCL stays "1".

11.6.3 Write operations to I²C slave

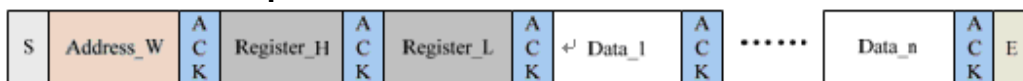

Write operations

Above is the flow chart of master CPU conducting write process for GT827. Master CPU launches a start signal and sends address, write and read information ("0" means write process -- 0xBA).

After receiving response, master CPU sends 16 bits address of register and writes 8 bits into register

The address pointer of GT827's register will automatically increase 1 in write process. So it can continuously write continuation register address at a time. If write process is done, master CPU sends stop signal.

11.6.4 Read operations to I²C slave



Read operation

Above is the flow chart of master CPU conducting read process for GT827. Master CPU launches a start signal and sends address, write and read information (“0” means read process -- 0XAA).

Once receives acknowledgement signal, master CPU sends 16 bits register address information and sets the read-demanding register address. Then master CPU resends a start signal for read process (0XAB). It begins to read data until receiving acknowledge.

Likewise, GT827 can conduct continuation read process. Master CPU will correspondingly send an acknowledgement signal to indicate successful byte reception. And CPU will send “NACK” once receiving the last byte to stop transmission.

11.7 Register information

Addr	R/W	Name	bit7	bit6	bit5	bit4	bit3	bit2	bit1	bit0
0XF40	R	Touch Flags	Buffer Status		L_touch	P4	P3	P2	P1	P0
0XF41	R	Touch key	Reserved				Key4	Key3	Key2	Key1
0XF42	R	Point0	Point0 X H							
0XF43	R		Point0 X L							
0XF44	R		Point0 Y H							
0XF45	R		Point0 Y L							
0XF46	R	Point1	Point0 Size							
0XF47	R		Point1 X H							
0XF48	R		Point1 X L							
0XF49	R		Point1 Y H							
0XF4A	R		Point1 Y L							
0XF4B	R		Point1 Size							
0XF4C	R	Point2	Point2 X H							
0XF4D	R		Point2 X L							
0XF4E	R		Point2 Y H							
0XF4F	R		Point2 Y L							
0XF50	R	Point3	Point2 Size							
0XF51	R		Point3 X H							
0XF52	R		Point3 X L							
0XF53	R		Point3 Y H							
0XF54	R		Point3 Y L							
0XF55	R	Point4	Point3 Size							
0XF56	R		Point4 X H							
0XF57	R		Point4 X L							
0XF58	R		Point4 Y H							
0XF59	R		Point4 Y L							
0XF5A	R	Point4 Size								
0XF5B	R	Coor checksum	Coordinate checksum							
0XF5C~0XF7C	-	NC	Reserved							
0xF7D	R	PID	Product ID(hex)							
0xF7E	R	VID_H	Product version High byte(hex)							

0xF7F	R	VID_L	Product version low byte(hex)
0xF80	R/W	DriverCH0	Screen 1 drives corresponding IC drive line
0xF81	R/W	DriverCH1	Screen 2 drives corresponding IC drive line
0xF82	R/W	DriverCH2	Screen 3 drives corresponding IC drive line
0xF83	R/W	DriverCH3	Screen 4 drives corresponding IC drive line
0xF84	R/W	DriverCH4	Screen 5 drives corresponding IC drive line
0xF85	R/W	DriverCH5	Screen 6 drives corresponding IC drive line
0xF86	R/W	DriverCH6	Screen 7 drives corresponding IC drive line
0xF87	R/W	DriverCH7	Screen 8 drives corresponding IC drive line
0xF88	R/W	DriverCH8	Screen 9 drives corresponding IC drive line
0xF89	R/W	DriverCH9	Screen 10 drives corresponding IC drive line
0xF8A	R/W	DriverCH10	Screen 11 drives corresponding IC drive line
0xF8B	R/W	DriverCH11	Screen 12 drives corresponding IC drive line
0xF8C	R/W	DriverCH12	Screen 13 drives corresponding IC drive line
0xF8D	R/W	DriverCH13	Screen 14 drives corresponding IC drive line
0xF8E	R/W	DriverCH14	Screen 15 drives corresponding IC drive line
0xF8F	R/W	DriverCH15	Screen 16 drives corresponding IC drive line
0xF90	R/W	DriverCH16	Screen 17 drives corresponding IC drive line
0xF91	R/W	DriverCH17	Screen 18 drives corresponding IC drive line
0xF92	R/W	DriverCH18	Screen 19 drives corresponding IC drive line
0xF93	R/W	DriverCH19	Screen 20 drives corresponding IC drive line
0xF94	R/W	DriverCH20	Screen 21 drives corresponding IC drive line
0xF95	R/W	DriverCH21	Screen 22 drives corresponding IC drive line
0xF96	R/W	DriverCH22	Screen 23 drives corresponding IC drive line
0xF97	R/W	DriverCH23	Screen 24 drives corresponding IC drive line
0xF98	R/W	DriverCH24	Screen 25 drives corresponding IC drive line
0xF99	R/W	DriverCH25	Screen 26 drives corresponding IC drive line
0xF9A	R/W	DriverCH26	Screen 27 drives corresponding IC drive line
0xF9B	R/W	DriverCH27	Screen 28 drives corresponding IC drive line
0xF9C	R/W	DriverCH28	Screen 29 drives corresponding IC drive line
0xF9D	R/W	NC	Reserved
0xF9E	R/W	SensorCH0	Screen 1 induction wire corresponds to IC drive line
0xF9F	R/W	SensorCH1	Screen 2 induction wire corresponds to IC drive line
0xFA0	R/W	SensorCH2	Screen 3 induction wire corresponds to IC drive line
0xFA1	R/W	SensorCH3	Screen 4 induction wire corresponds to IC drive line
0xFA2	R/W	SensorCH4	Screen 5 induction wire corresponds to IC drive line
0xFA3	R/W	SensorCH5	Screen 6 induction wire corresponds to IC drive line
0xFA4	R/W	SensorCH6	Screen 7 induction wire corresponds to IC drive line
0xFA5	R/W	SensorCH7	Screen 8 induction wire corresponds to IC drive line
0xFA6	R/W	SensorCH8	Screen 9 induction wire corresponds to IC drive line
0xFA7	R/W	SensorCH9	Screen 10 induction wire corresponds to IC drive line
0xFA8	R/W	SensorCH10	Screen 11 induction wire corresponds to IC drive line
0xFA9	R/W	SensorCH11	Screen 12 induction wire corresponds to IC drive line
0xFAA	R/W	SensorCH12	Screen 13 induction wire corresponds to IC drive line
0xFAB	R/W	SensorCH13	Screen 14 induction wire corresponds to IC drive line
0xFAC	R/W	SensorCH13	Screen 15 induction wire corresponds to IC drive line
0xFAD	R/W	SensorCH14	Screen 16 induction wire corresponds to IC drive line
0XFAE~ 0XFB1	-	NC	Reserved
0xFB2	R/W	ADCCFG	chip scanning control parameter
0xFB3	R/W	SCAN	chip scanning control parameter
0xFB4	R/W	F1SET	drive pulse 1 frequency
0xFB5	R/W	F2SET	drive pulse 2 frequency

0xFB6	R/W	F3SET	drive pulse 3 frequency							
0xFB7	R/W	F1PNUM	1 drive pulse							
0xFB8	R/W	F2PNUM	2 drive pulse							
0xFB9	R/W	F3PNUM	3 drive pulse							
0xFBA	R/W	F1DELAY	drive pulse 1 phase delay							
0xFBB	R/W	F2DELAY	drive pulse 2 phase delay							
0xFBC	R/W	F3DELAY	drive pulse 3 phase delay							
0xFBD	R/W	DC-DC	high pressure setting							
0xFBE	R/W	Sc_Touch	TP key threshold							
0xFBF	R/W	Sc_Leave	TP key up threshold							
0xFC0	R/W	Md_switch	Reserved	DD2: difference And half	Reserved	Shape_EN defamation denoise	INT pulse mode	SITO denoise switch	Reserved	Reserved
0xFC1	R/W	LPower_C	Reserved	time to low power consumption without pressing: 0-63s valid, unit: S						
0xFC2	R/W	Refresh	0-100 valid; 0: period 10ms, 100: period 20ms							
0xFC3	R/W	Touch_N	Reserved	Reserved	Output touch point, 1-5 valid					
0xFC4	R/W	Output_Th	output limit: output until coordinate transformation value is higher than this, 0-254 configurable (unit:4 coordinate),255 means first pressing coordinate and keying up							
0xFC5	R/W	X_Ou_Max_H	X direction output maximum coordinate, the higher byte placed first							
0xFC6	R/W	X_Ou_Max_L								
0xFC7	R/W	Y_Ou_Max_H	Y direction output maximum coordinate, the higher byte placed first							
0xFC8	R/W	Y_Ou_Max_L								
0xFC9	R/W	X_Co_Sm	X direction slide control parameter, 0-255 configurable, 0 means closure							
0xFCA	R/W	Y_Co_Sm	Y direction slide control parameter, 0-255 configurable, 0 means closure							
0xFCB	R/W	X_Sp_Lim	X direction maximum speed limit of slide: 0-255 configurable, 0 means closure(unit:16 coordinate)							
0xFCC	R/W	Y_Sp_Lim	Y direction maximum speed limit of slide: 0-255 configurable, 0 means closure(unit:16 coordinate)							
0xFCD	R/W	Noise_R	sampling drop-driven				while noise elimination: 0-15 valid			
0xFCE	R/W	NC	Reserved							
0xFCF	R/W	Filter	Reserved				coordinate window filtering value (in base 4)			
0xFD0	R/W	Large_Tc	representative touch points for large area: 0-255 valid							
0xFD1	R/W	Shake_Cu	Touch Shake Count				Finger Number Shake Count			
0xFD2	R/W	Pos_Ref_T	benchmark update configuration in normal condition, 0-255 valid, 0 means close benchmark update							
0xFD3	R/W	NC	benchmark update configuration in sudden change condition,0-255 valid, 0 means close benchmark update							
0xFD4	R/W	NC	Reserved							
0xFD5	R/W	NC								
0xFD6	R/W	Edge_exp	Reserved				0: weak tensile 1: strong			
0xFD7	R/W	Tc_K_F	Key_com	Key_con	Reserved	valid interval in regional keys (unilateral): 0-15 valid				
0xFD8	R/W	Key 1	Key 1 position: 0-255 valid, 0 means unavailable							
0xFD9	R/W	Key 2	Key 2 position: 0-255 valid, 0 means unavailable							
0xFDA	R/W	Key 3	Key 3 position: 0-255 valid, 0 means unavailable							
0xFDB	R/W	Key 4	Key 4 position: 0-255 valid, 0 means unavailable							
0xFDC	R/W	K_Touch	key threshold							
0xFDD	R/W	K_Leave	key up threshold							
0xFDE	R/W	K_SEC_max	upper limit of sub-maximum difference in independent key judgment							
0xFE0	R/W	K_DIS_min	lower limit of difference between maximum and sub-maximum in independent key judgment							
0xFE0	R/W	X_border_Lim_Near	discarded coordinate numbers on X proximal border							

0xFE1	R/W	X_border_Lim_Far	discarded coordinate numbers on X far end			
0xFE2	R/W	Y_border_Lim_Near	discarded coordinate numbers on Y proximal border			
0xFE3	R/W	Y_border_Lim_Far	discarded coordinate numbers on Y far end			
0xFE4	R/W	KEY_ADCCFG	FPC ADCCFG parameter (applicable to drive key common port)			
0xFE5	R/W	KEY_F1SET	FPC drive frequency setting (applicable to drive key common port)			
0xFE6	R/W	KEY_F1NUM	FPC drive pulse number setting (applicable to drive key common port)			
0xFE7	R/W	Key_Shake_Cu	touch key Shake counter (0-255)			
0xFE8	R/W	Key2_Touch	touch Level of FPC touch key2			
0xFE9	R/W	Key3_Touch	touch Level of FPC touch key3			
0xFEA	R/W	Key4_Touch	touch Level of FPC touch key4			
0xFEB~ 0xFEE	-	NC	Reserved			
0xFEf	R/W	Con_Frs	mark for configuration update, write 1 when master completing configuration information			
0xFF0	R/W	Cfg_Chk_H	configuration information checksum, the higher byte placed first			
0xFF1	R/W	Cfg_Chk_L				
0xFF2	R/W	System_Sta	Power_sta		Reserved	
0xFF3	R/W	LED_Con	LED_EN	LED_CM	LED_SW	time of light-on after key up (unit: S)
0xFF4	R/W	Command	Reserved			
0xFF5	R/W	Module_Type	Reserved			module supplier' ID: 0-2 valid

12. Appearance Specification

12.1 Inspection and Environment conditions

- 12.1.1 Temperature: 22±2
- 12.1.2 Humidity: 55±5%RH
- 12.1.3 Light source: Fluorescent Light
- 12.1.4 Inspection: Viewing distance: 35±5cm
- 12.1.5 Ambient Illumination:
 - (1) Cosmetic Inspection: 500 ~ 800 lux
 - (2) Functional Inspection: 400 ~ 600 lux
- 12.1.6 Inspection View angle:
 - (1) Inspection under operating condition : ±5°
 - (2) Inspection under non-operating condition : ± 45°

12.2 Appearance inspection

Appearance inspection method:

Front visual distance: 30-40CM

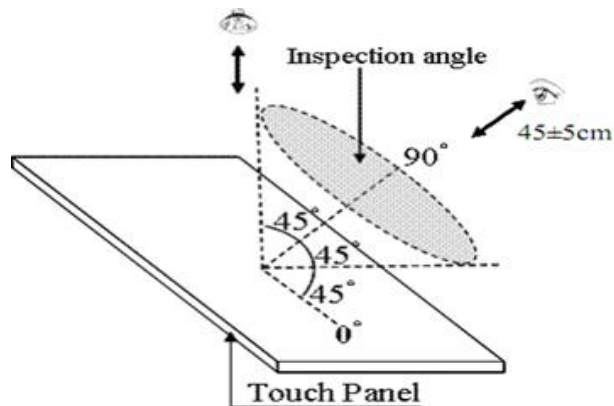

12.3 Judgment standard





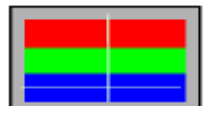

The Judgment of the above test should be made after exposure in room temperature for two hours as follow:

Pass: Normal display image with no obvious non-uniformity and no line defect. Partial transformation of the module parts should be ignored.

Fail: No display image, obvious non-uniformity, or line defect.

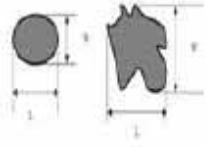
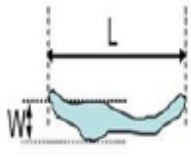
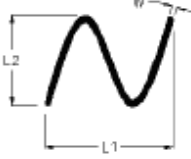
12.4 Cosmetic Specification and Inspection Items

Inspection item	Inspection standard	Description
Display function	No display function	
Contrast	Out of SPEC	
Line defect	No obvious vertical or horizontal line defect (black line or white line)	

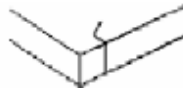
<p>Dot defect</p>	<table border="1"> <thead> <tr> <th>Item</th> <th>Acceptable quantity</th> <th>Total</th> </tr> </thead> <tbody> <tr> <td>Bright dot</td> <td>2</td> <td></td> </tr> <tr> <td>Dark dot</td> <td>4</td> <td></td> </tr> <tr> <td>Two adjacent dark dots</td> <td>2</td> <td></td> </tr> </tbody> </table>	Item	Acceptable quantity	Total	Bright dot	2		Dark dot	4		Two adjacent dark dots	2		<p>One Dot </p> <p>Two adjacent dot </p>
Item	Acceptable quantity	Total												
Bright dot	2													
Dark dot	4													
Two adjacent dark dots	2													
<p>Dot of foreign material</p>	<table border="1"> <thead> <tr> <th>SPEC</th> <th>Acceptable quantity</th> <th>Total</th> </tr> </thead> <tbody> <tr> <td>D>0.8mm</td> <td></td> <td>0</td> </tr> <tr> <td>0.3mm D 0.8mm</td> <td></td> <td>5</td> </tr> <tr> <td>D<0.3mm</td> <td></td> <td>Ignorable</td> </tr> </tbody> </table>	SPEC	Acceptable quantity	Total	D>0.8mm		0	0.3mm D 0.8mm		5	D<0.3mm		Ignorable	 <p>$D = (L + W) / 2$</p>
SPEC	Acceptable quantity	Total												
D>0.8mm		0												
0.3mm D 0.8mm		5												
D<0.3mm		Ignorable												
<p>Line of foreign material</p>	<table border="1"> <thead> <tr> <th>SPEC</th> <th>Acceptable quantity</th> <th>Total</th> </tr> </thead> <tbody> <tr> <td>W>0.1mm L>10mm</td> <td></td> <td>0</td> </tr> <tr> <td>0.05mm W 0.1mm L 10mm</td> <td></td> <td>5</td> </tr> <tr> <td>W<0.05mm</td> <td></td> <td>Ignorable</td> </tr> </tbody> </table>	SPEC	Acceptable quantity	Total	W>0.1mm L>10mm		0	0.05mm W 0.1mm L 10mm		5	W<0.05mm		Ignorable	 <p>L : Long W : Width</p>
SPEC	Acceptable quantity	Total												
W>0.1mm L>10mm		0												
0.05mm W 0.1mm L 10mm		5												
W<0.05mm		Ignorable												
<p>Image uniformity</p>	<p>Through ND5%, invisible at R G B ,grey and white</p>													
<p>Size</p>	<p>According to SPEC</p>													
<p>TP scratch</p>	<table border="1"> <thead> <tr> <th>SPEC</th> <th>Acceptable quantity</th> <th>Total</th> </tr> </thead> <tbody> <tr> <td>W>0.1mm L>10mm</td> <td></td> <td>0</td> </tr> <tr> <td>W 0.1mm L 10mm</td> <td></td> <td>5</td> </tr> </tbody> </table>	SPEC	Acceptable quantity	Total	W>0.1mm L>10mm		0	W 0.1mm L 10mm		5				
SPEC	Acceptable quantity	Total												
W>0.1mm L>10mm		0												
W 0.1mm L 10mm		5												
<p>TP dent dot</p>	<table border="1"> <thead> <tr> <th>SPEC</th> <th>Acceptable quantity</th> <th>Total</th> </tr> </thead> <tbody> <tr> <td>D>0.5mm</td> <td></td> <td>0</td> </tr> <tr> <td>0.3 D 0.5mm</td> <td></td> <td>5</td> </tr> </tbody> </table>	SPEC	Acceptable quantity	Total	D>0.5mm		0	0.3 D 0.5mm		5	 <p>$D = (L + W) / 2$</p>			
SPEC	Acceptable quantity	Total												
D>0.5mm		0												
0.3 D 0.5mm		5												
<p>TP glue overflow</p>	<p>±0.45mm</p>													
<p>Surface damage</p>	<p>X<3mm Y<3mm Z<glass</p>													
<p>Edge damage</p>	<p>X<3mm Y<3mm Z<glass</p>													
<p>TP crack</p>	<p>prohibited</p>													

Bubble in protective film	SPEC quantity D>1.0mm N=0 0.5<D<1.0mm N=2 D<0.5 Ignorable	Acceptable	
TP deviation	According to customer drawing spec		
Bubble	D 0.2mm ignorable 0.2mm < D 0.5mm 2 bubbles accepted 0.5mm < D prohibited		
Printing ink	Light leak is prohibited. Printing serrated : S 0.1 ignorable S 0.15 NG Break line on LOGO NG Blur printing , inverse printing , print in wrong position		

12.5 Sampling plan

General problem	Definition		
	primary	AQL0.65%	Completely fail to be used due to defect.
	Secondary	AQL1.5%	Still can be used due to small defect.

13. QUALITY ASSURANCE

13.1 Test Condition

13.1.1 Temperature and Humidity(Ambient Temperature)

Temperature : $25 \pm 5^{\circ}\text{C}$

Humidity : $65 \pm 5\%$

13.1.2 Operation

Unless specified otherwise, test will be conducted under function state.

13.1.3 Container

Unless specified otherwise, vibration test will be conducted to the product itself without putting it in a container.

13.1.4 Test Frequency

In case of related to deterioration such as shock test. It will be conducted only once.

13.1.5 Test Method

Reliability Test Item & Level		Test Level
No.	Test Item	
1.	Low Temperature Storage Test	T= -20 ,120hrs after 24 hrs at room temperature and test.
2.	High Temperature Storage Test	T= 70 ,120hrs after 24 hrs at room temperature and test.
3.	Low Temperature Operation Test	T= -10 ,120hrs after 24 hrs at room temperature and test.
4.	High Temperature Operation Test	T= 60 ,120hrs after 24 hrs at room temperature and test.
5.	High Temperature and High Humidity Operation Test	T= 40 , 90%RH,120hrs after 24 hrs at room temperature and test.
6.	Thermal Cycling Test (No operation)	-20 30min ~ 70 30 min , 100 Cycles after 24 hrs at room temperature and test.
7.	Vibration Test (No operation)	Frequency :10 ~ 55 HZ Amplitude :1.5 mm Sweep time : 11 mins Test Period: 6 Cycles for each direction of X, Y, Z
8.	ESD TEST	Air Discharge : $\pm 15\text{KV}$ Indirect Contact Discharge : $\pm 8\text{KV}$

13.2 Judgment standard

The Judgment of the above test should be made after exposure in room temperature for two hours as follow:

Pass: Normal display image with no obvious non-uniformity and no line defect. Partial transformation of the module parts should be ignored.

Fail: No display image, obvious non-uniformity, or line defect.

14. LCM PRODUCT LABEL DEFINE

Product Label style:

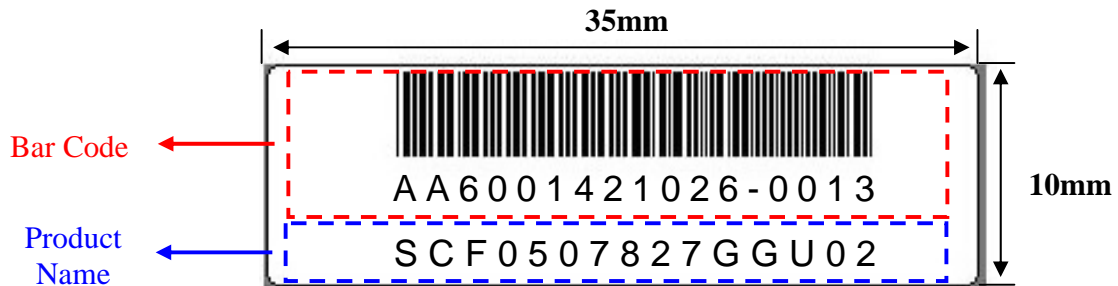

BarCode Define:

A A 6 0014 2 10 26-0013

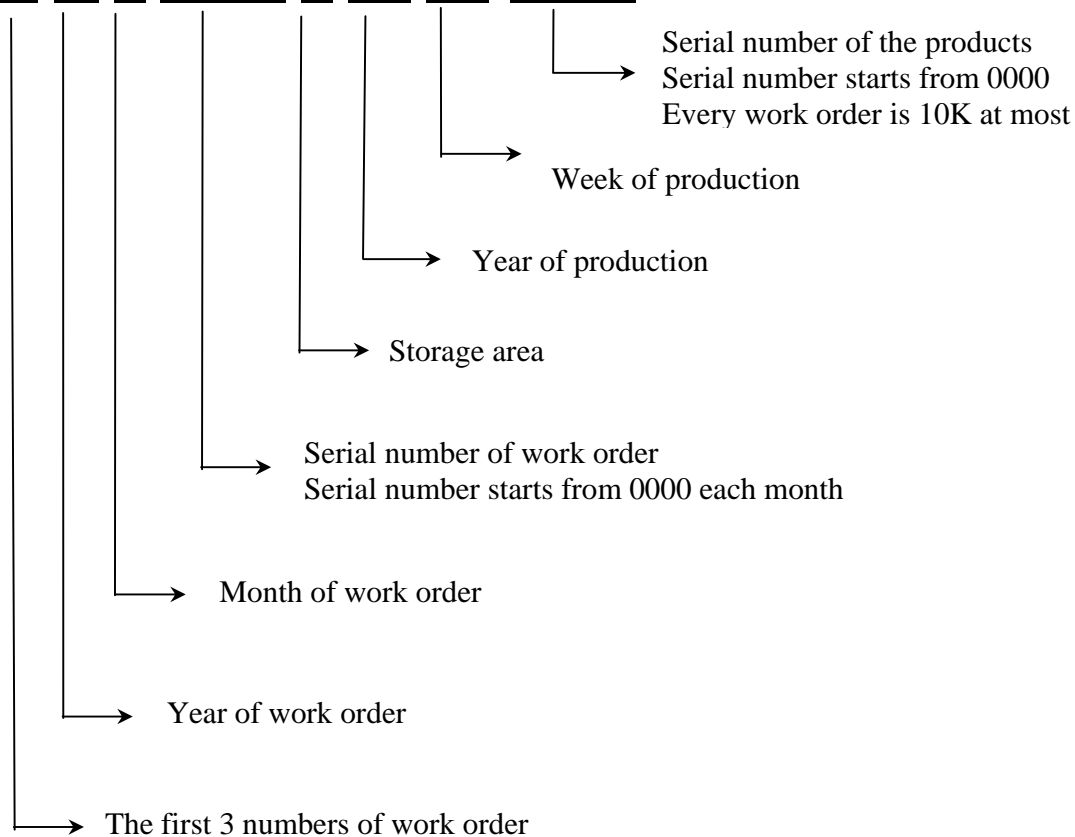

Product Name Define:

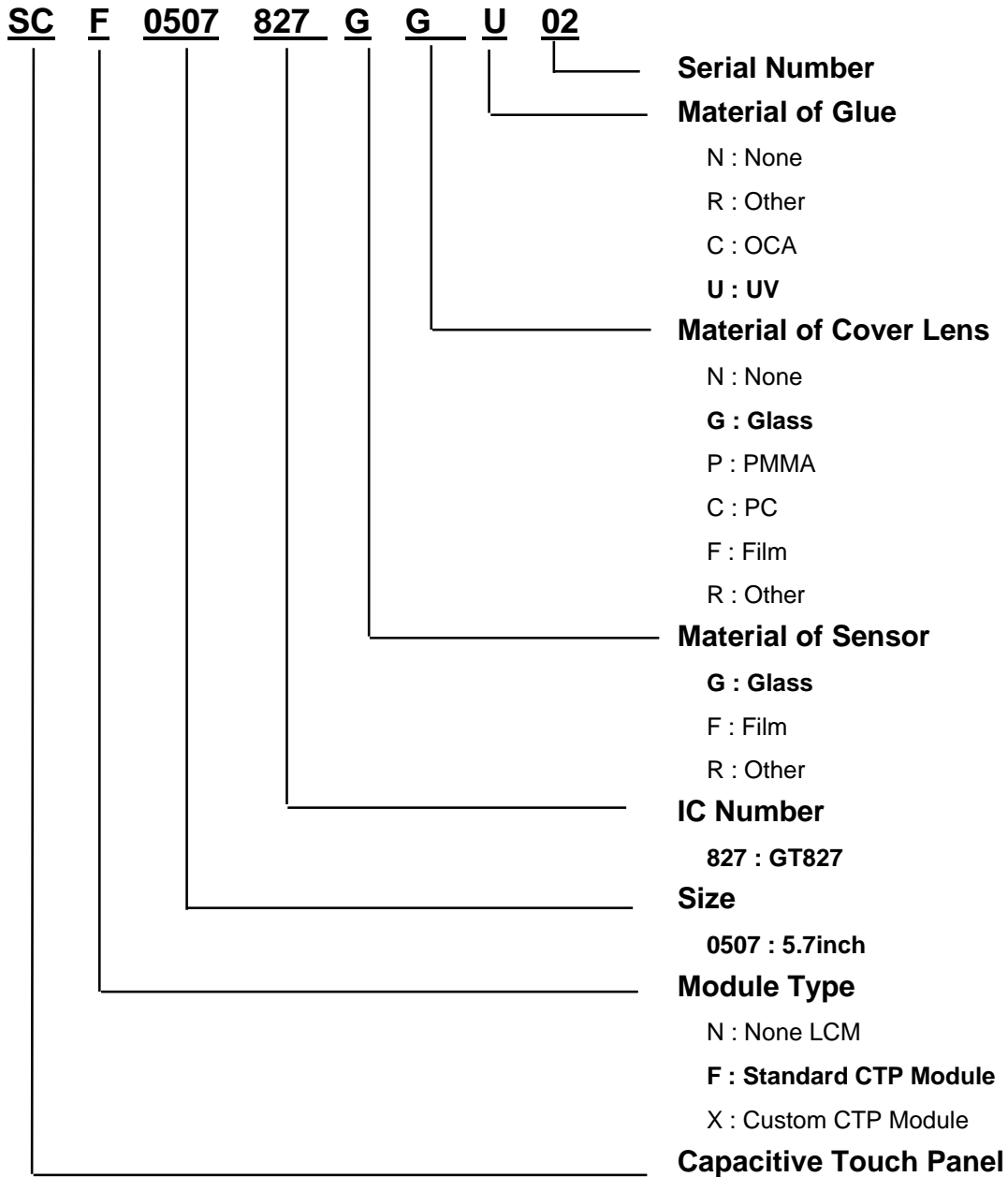

15. PRECAUTIONS IN USE LCM

1. LIQUID CRYSTAL DISPLAY (LCD)

LCD is made up of glass, organic sealant, organic fluid, and polymer based polarizers. The following precautions should be taken when handling,

- (1). Keep the temperature within range of use and storage. Excessive temperature and humidity could cause polarization degradation, polarizer peel off or bubble.
- (2). Do not contact the exposed polarizers with anything harder than an HB pencil lead. To clean dust off the display surface, wipe gently with cotton, chamois or other soft material soaked in petroleum benzine.
- (3). Wipe off saliva or water drops immediately. Contact with water over a long period of time may cause polarizer deformation or color fading, while an active LCD with water condensation on its surface will cause corrosion of ITO electrodes.
- (4). Glass can be easily chipped or cracked from rough handling, especially at corners and edges.
- (5). Do not drive LCD with DC voltage.

2. Liquid Crystal Display Modules

2.1 Mechanical Considerations

LCM are assembled and adjusted with a high degree of precision. Avoid excessive shocks and do not make any alterations or modifications. The following should be noted.

- (1). Do not tamper in any way with the tabs on the metal frame.
- (2). Do not modify the PCB by drilling extra holes, changing its outline, moving its components or modifying its pattern.
- (3). Do not touch the elastomer connector, especially insert an backlight panel (for example, EL).
- (4). When mounting a LCM make sure that the PCB is not under any stress such as bending or twisting. Elastomer contacts are very delicate and missing pixels could result from slight dislocation of any of the elements.
- (5). Avoid pressing on the metal bezel, otherwise the elastomer connector could be deformed and lose contact, resulting in missing pixels.

2.2. Static Electricity

LCM contains CMOS LSI's and the same precaution for such devices should apply, namely

- (1). The operator should be grounded whenever he/she comes into contact with the module. Never touch any of the conductive parts such as the LSI pads, the copper leads on the PCB and the interface terminals with any parts of the human body.
- (2). The modules should be kept in antistatic bags or other containers resistant to static for storage.
- (3). Only properly grounded soldering irons should be used.
- (4). If an electric screwdriver is used, it should be well grounded and shielded from commutator sparks.

- (5) The normal static prevention measures should be observed for work clothes and working benches; for the latter conductive (rubber) mat is recommended.
- (6). Since dry air is inductive to statics, a relative humidity of 50-60% is recommended.

2.3 Soldering

- (1). Solder only to the I/O terminals.
- (2). Use only soldering irons with proper grounding and no leakage.
- (3). Soldering temperature : $280^{\circ}\text{C} \pm 10^{\circ}\text{C}$
- (4). Soldering time: 3 to 4 sec.
- (5). Use eutectic solder with resin flux fill.
- (6). If flux is used, the LCD surface should be covered to avoid flux spatters. Flux residue should be removed after wards.

2.4 Operation

- (1). The viewing angle can be adjusted by varying the LCD driving voltage V_0 .
- (2). Driving voltage should be kept within specified range; excess voltage shortens display life.
- (3). Response time increases with decrease in temperature.
- (4). Display may turn black or dark blue at temperatures above its operational range; this is (however not pressing on the viewing area) may cause the segments to appear "fractured".
- (5). Mechanical disturbance during operation (such as pressing on the viewing area) may cause the segments to appear "fractured".

2.5 Storage

If any fluid leaks out of a damaged glass cell, wash off any human part that comes into contact with soap and water. Never swallow the fluid. The toxicity is extremely low but caution should be exercised at all the time.

2.6 Limited Warranty

Unless otherwise agreed between DATA IMAGE and customer, DATA IMAGE will replace or repair any of its LCD and LCM which is found to be defective electrically and visually when inspected in accordance with DATA IMAGE acceptance standards, for a period on one year from date of shipment. Confirmation of such date shall be based on freight documents. The warranty liability of DATA IMAGE is limited to repair and/or replacement on the terms set forth above. DATA IMAGE will not be responsible for any subsequent or consequential events.

16. OUTLINE DRAWING

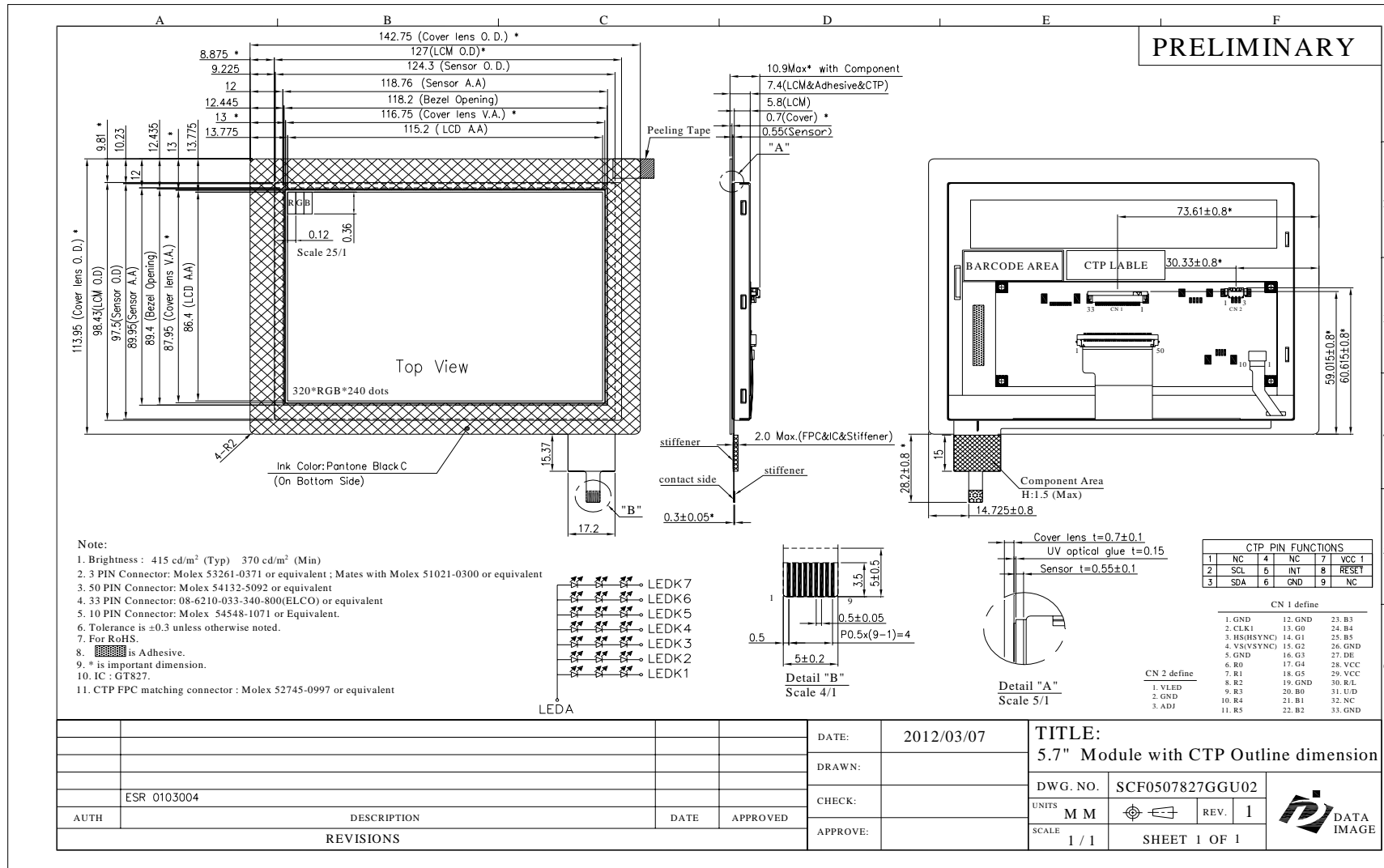

17. PACKAGE INFORMATION

TBD