

TFT-DISPLAY DATASHEET

ONation
Model: OT070PGDDDV-00

BRIEF SPEC.:

Main Feature	LandscapeType Transmissive
Active Screen Area	154.8 x 85.92 (mm)
Diagonal Format	7 " 15:9
Resolution	800 X 480
Colors	(8 Bit)
Backlight	LED
Brightness	400 cd/m ²
LED Life Time	20K (h)
Interface	TTL
Viewing Angle	70/70 L/R 50/70 up/down
Touchscreen	No
Power Supply	3.3 V (Typ.)
Module Outline	164.9 x 100.0 x 8.7 (mm)
Operation Temperature	-30... +85 °C
Storage Temperature	-30... +85 °C
Surface Treatment	Anti-glare



ONation Corporation

TFT COLOR LCD MODULE

MODEL: OT070PGDDDV-00

WVGA
TTL interface
Version: P0.1

Customer : _____
Approved By : _____
Date: _____

ONATION		
APPROVAL	CHECKER	PREPARE

[All information is subject to change without notice.](#)
[Please confirm the sales representative before starting to design your system](#)

CONTENTS

NO.	ITEM	PAGE
1	RECORD OF REVISION	0-1
2	MECHANICAL SPECIFICATIONS	1
3	OUTLINE DIMENSIONS	2
4	INTERFACE PIN CONNECTION	3~4
5	BLOCK DIAGRAM	5
6	ABSOLUTE MAXIMUM RATINGS	5
7	ELECTRICAL CHARACTERISTICS	6
8	OPTICAL CHARACTERISTICS	7~9
9	TIMING SPECIFICATIONS	10~12
10	RELIABILITY TEST	13~14
11	MODEL NUMBER SYSTEM	15
12	LCM INSPECTION STANDARD	16
13	PACKAGE INFORMATION	16
14	PRECAUTIONS FOR USE	17

1.RECORD OF REVISION

REV	DATE	PAGE	SUMMARY
0.1	2014.01.28	ALL	Preliminary specification was first issued.

2.MECHANICAL SPECIFICATIONS

(1)	Number Of Dots (Dots)	800(R.G.B) X 480
(2)	Module Size(mm)	164.9(H) X 100.0(V) X8.7(D)
(3)	Active Area(mm)	154.08(H) X 85.92(V)
(4)	Pixel Pitch(mm)	0.1926 (H) X 0.1790(V)
(5)	LCD / Polarizer Model	TFT , Transmissive, Normally/White, Anti-Glare
(6)	Backlight Color	White, LED
(7)	Viewing Direction	12O'clock Horizontal : Right side 70°(typ.), Left side 70°(typ.) Vertical : Up side 50°(typ.), Down side 70°(typ.)
(8)	Gray Scale Inversion Direction	6O'clock
(9)	Electrical Interface	TTL Interface
(10)	Color Configuration	R.G.B Stripe
(11)	Module Weight(g)	TBD

3. OUTLINE DIMENSIONS

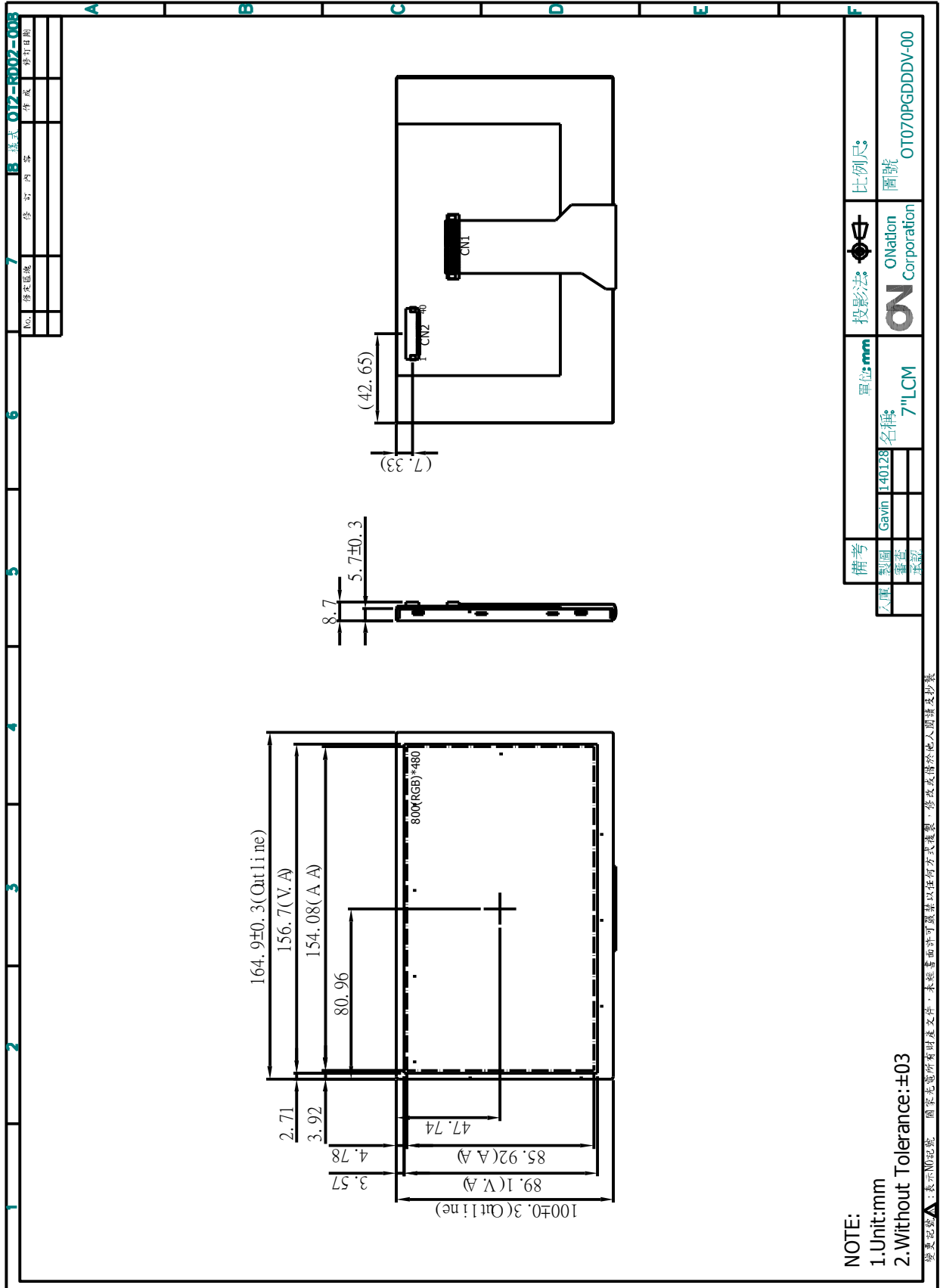

4. INTERFACE PIN CONNECTION

4.1 LCM PANEL DRIVING SECTION

CN2 Connector : STM MS2406P40M or Equivalen

PIN NO.	SIGNAL	FUNCTION
1	VDD	Digital Power
2	VDD	Digital Power
3	GND	Ground
3	GND	Ground
5	DCLK	Clock Input
6	NC	No Connection
7	R0	Red Data(LSB)
8	R1	Red Data
9	R2	Red Data
10	R3	Red Data
11	R4	Red Data
12	R5	Red Data
13	R6	Red Data
14	R7	Red Data(MSB)
15	G0	Green Data(LSB)
16	G1	Green Data
17	G2	Green Data
18	G3	Green Data
19	G4	Green Data
20	G5	Green Data
21	G6	Green Data
22	G7	Green Data(MSB)
23	B0	Blue Data(LSB)
24	B1	Blue Data
25	B2	Blue Data
26	B3	Blue Data
27	B4	Blue Data
28	B5	Blue Data
29	B6	Blue Data
30	B7	Blue Data(MSB)
31	GND	Ground
32	GND	Ground
33	NC	No Connection
34	HS	Horizontal Sync Input
35	VS	Vertical Syan Input

36	DE	Data Input Enable
37	NC	No Connection
38	ADJ	Adjust The Back Light Brightness
39	VLED	Power Supply for LED Driver Circuit
40	VLED	Power Supply for LED Driver Circuit

5. BLOCK DIAGRAM

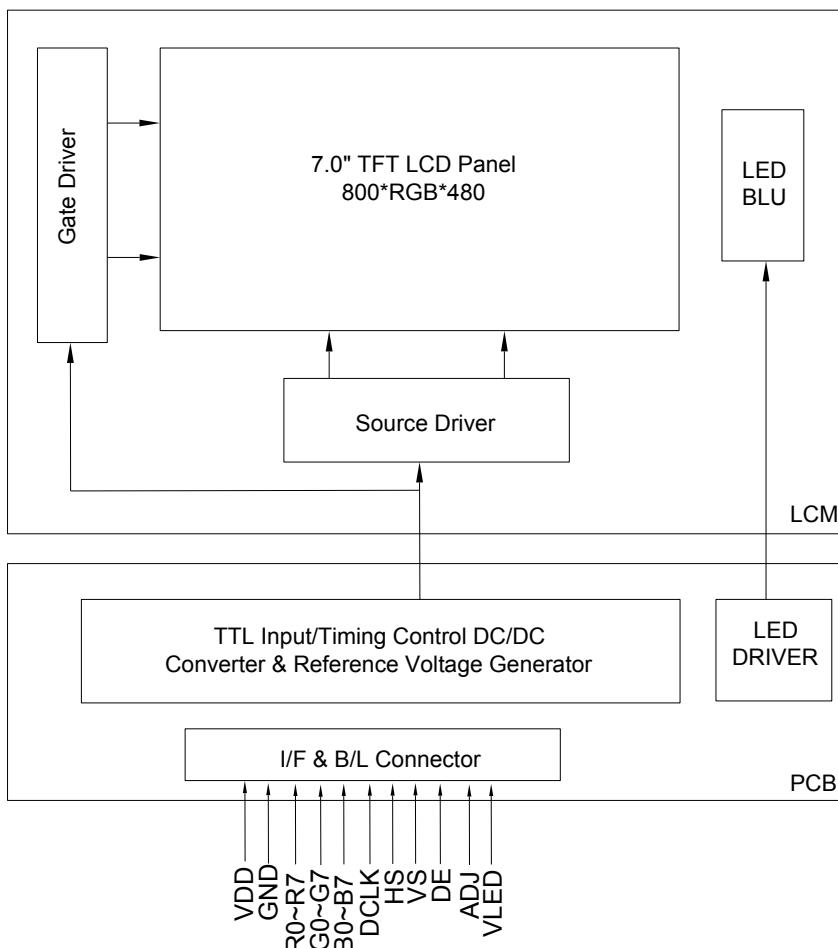

6. ABSOLUTE MAXIMUM RATINGS

6.1 ELECTRICAL ABSOLUTE MAXIMUM RATINGS

ITEM	SYMBOL	MIN.	MAX.	UNIT	REMARK
Supply Voltage	VDD	-0.3	5.0	V	
	VLED	-0.3	40	V	

6.2 ENVIRONMENTAL ABSOLUTE MAXIMUM RATINGS

ITEM	OPERATING		STORAGE		REMARK
	MIN.	MAX.	MIN.	MAX.	
Ambient Temperature(□)	(-30)	(85)	(-30)	(85)	Note 1,2
Humidity(% RH)	Note 3		Note 3		Without condensation

Note 1 : The response time will become lower when operated at low temperature.

Note 2 : Background color changes slightly depending on ambient temperature.

Note 3 : Ta□60□: 90%RH max , without condensation.

Ta>60□: Absolute humidity shall be less than the value of 90%RH at 60□ without condensation

7. ELECTRICAL CHARACTERISTICS

7.1 ELECTRICAL CHARACTERISTICS OF LCD

Ta=25□

ITEM	SYMBOL	MIN.	TYP.	MAX.	UNIT	REMARK
Power Voltage For LCD	VDD	3.0	3.3	3.6	V	
	IDD	-	TBD	TBD	mA	Note1

Note 1 : Test Condition: VDD=3.3V ; Test Pattern: Black.

7.2 BACKLIGHT UNITS

Ta=25□

ITEM	SYMBOL	MIN.	TYP.	MAX.	UNIT	REMARK
LED Driving Voltage	VLED	-	5	12	V	Note 1
LED Driving Current	ILED	-	TBD	TBD	mA	
LED Life Time	-	20000	-	-	Hrs	Note 2

Note 1: The LED Supply Voltage is defined by the number of LED at Ta=25□ and IL=180mA.

Note 2: The "LED life time" is defined as the module brightness decrease to 50% original brightness at Ta=25□ and IL=180mA. The LED lifetime could be decreased if operating IL is larger than 180mA.

8. OPTICAL CHARACTERISTICS

Ta=25℃

ITEM		SYMBOL	CONDITIONS	MIN.	TYP.	MAX.	UNIT	REMARK
Contrast Ratio		CR	Viewing Normal Angle $\Theta_x = \Theta_y = 0^\circ$	400	500	-	-	Note 1
Response Time		TR+TF		-	25	50	ms	Note 2
Chromaticity	White	x	Viewing Angle $\Theta_x = \Theta_y = 0^\circ$ CR \square 10	0.260	0.310	0.360	-	Note 4
		y		0.280	0.330	0.380	-	
Viewing Angle	Hor.	θ_{x+}		60	70	-	Deg.	Note 3
		θ_{x-}		60	70	-		
	Ver.	θ_{y+}	40	50	-			
		θ_{y-}	60	70	-			
Luminance		L	PWM=100%	320	400	-	cd/m ²	Note 5
Luminance Uniformity		YU		70	75	-	%	

Note 1 : Definition of Contrast Ratio (CR) :

The contrast ratio can be calculated by the following expression.

$$\text{Contrast Ratio (CR)} = L_{63}/L_0$$

L63 : Luminance of gray level 63

L0 : Luminance of gray level 0

$$CR = CR(5)$$

CR(X) is corresponding to the Contrast Ratio of the point X at Figure in Note 5

Note 2 : Definition of Response Time (TR.TF)

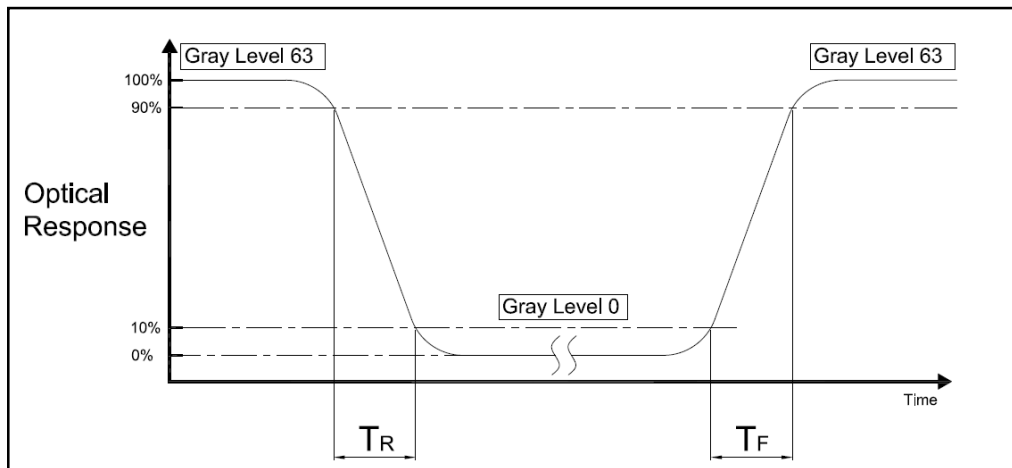

Note 3 : Definition of Viewing Angle

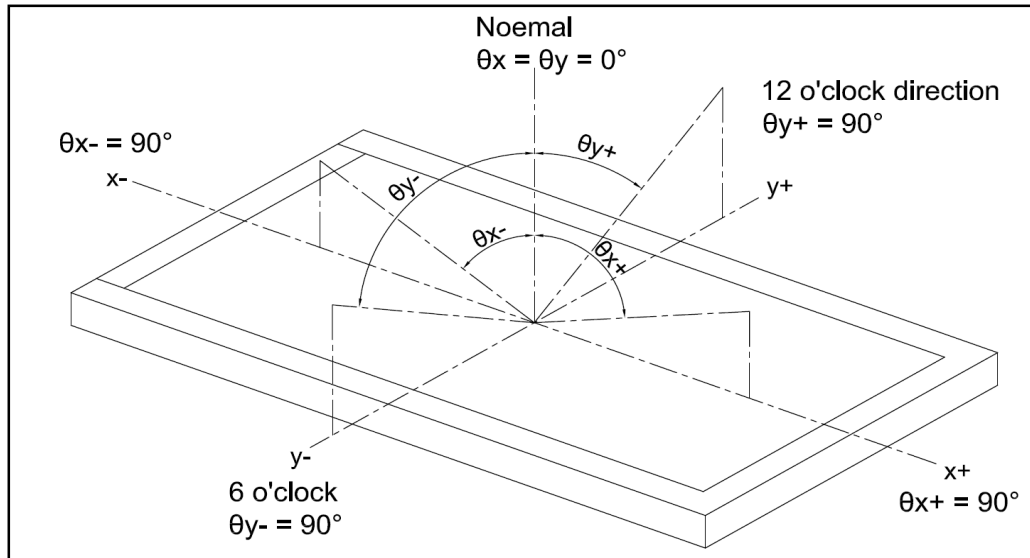

Note 4 : Measurement Set-Up:

The LCD module should be stabilized at a given temperature for 20 minutes to avoid abrupt temperature change during measuring. In order stabilize the luminance, the measurement should be executed after lighting Backlight for 20 minutes in a windless room.

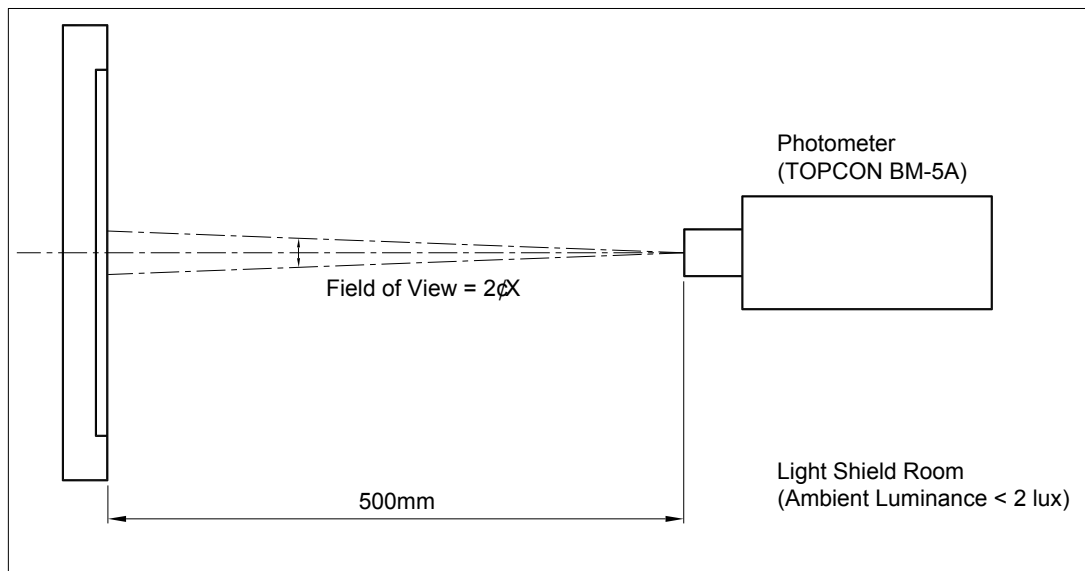

Note 5 :

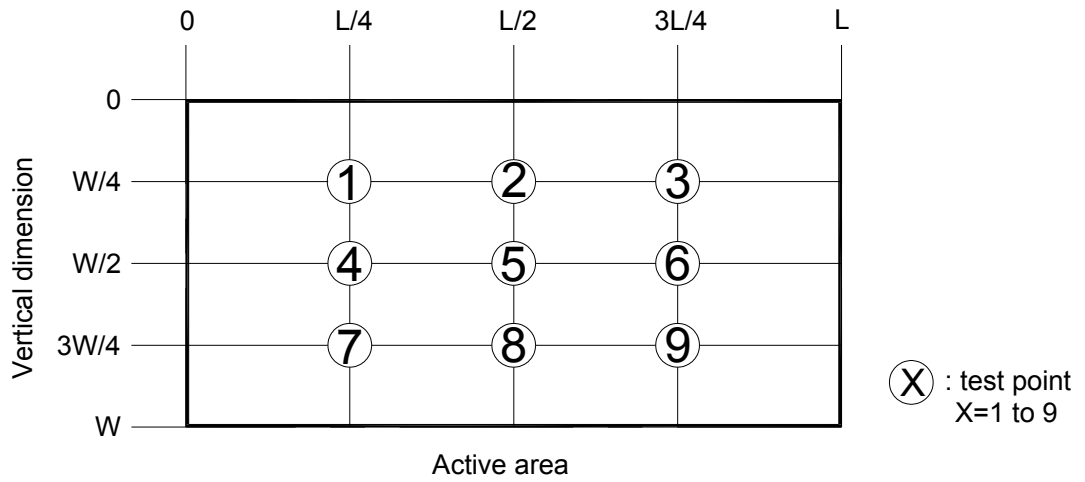

$$\left(1 - \frac{\text{MAX Luminance} - \text{Average Luminance}}{\text{Average Luminance}} \right) \times 100\% \geq 70\%$$

9. TIMING SPECIFICATIONS

9.1 POWER SEQUENCE

Power Signal Sequence :

$t1 \leq 10\text{ms}$; $1\text{sec} \leq t5$

$200\text{ms} \leq t2$; $200\text{ms} \leq t6$

$0 \leq t3 \leq 50\text{ms}$; $200\text{ms} \leq t7$

$0 \leq t4 \leq 10\text{ms}$

LCD Power Supply
Logic Signal

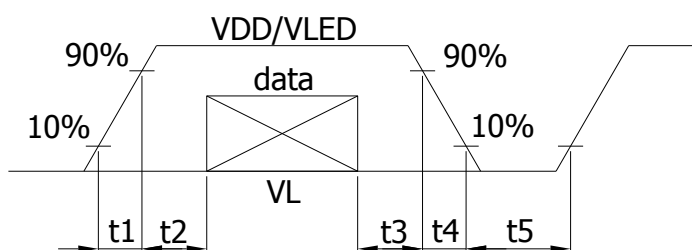

9.2 AC ELECTRICAL CHARACTERISTICS

ITEM	SYMBOL	MIN.	TYP.	MAX.	UNIT	REMARK
HS Setup Time	T _{hst}	8	-	-	ns	
HS Hold Time	T _{hhd}	8	-	-	ns	
VS Setup Time	T _{vst}	8	-	-	ns	
VS Hold Time	T _{vhd}	8	-	-	ns	
Data Setup Time	T _{dsu}	8	-	-	ns	
Data Hold Time	T _{dhd}	8	-	-	ns	
DE Setup Time	T _{esu}	8	-	-	ns	
DE Hold Time	T _{ehd}	8	-	-	ns	
VDD Power On Slew Rate	TPOR	-	-	20	ms	From 0 to 90% VDD
RESET Pulse Width	T _{Rst}	1	-	-	ms	
DCLK Cycle Time	T _{coh}	20	-	-	ns	
DCLK Pulse Duty	T _{cwh}	40	50	60	%	

9.3 INPUT CLOCK AND DATA TIMING DIAGRAM

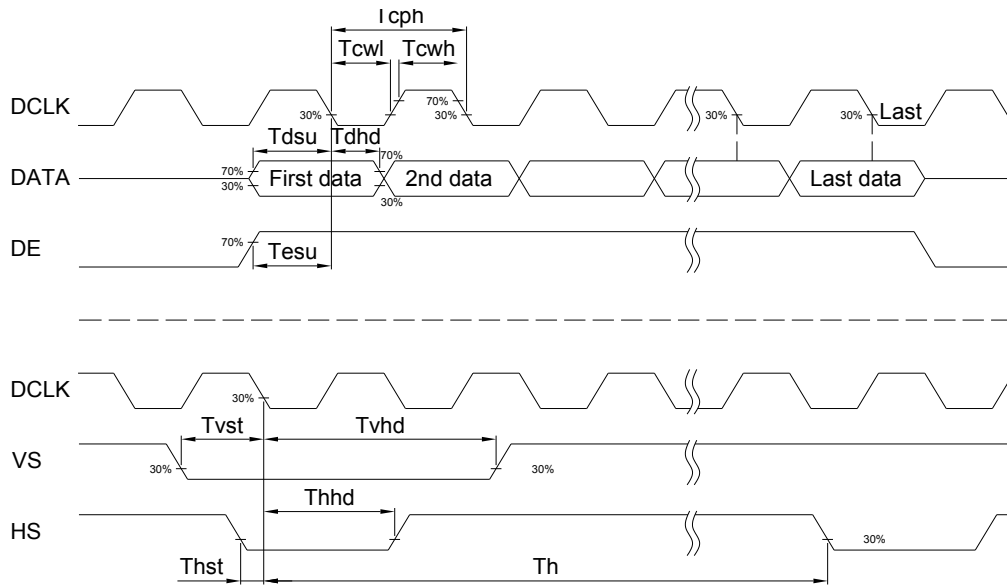

9.4 TIMING

9.4.1 Horizontal INPUT TIMING

ITEM	SYMBOL	MIN.	TYP.	MAX.	UNIT
Horizontal Display Area	thd	-	800	-	DCLK
DCLK Frequency	fclk	26.4	33.3	46.8	MHz
One Horizontal Line	th	862	1056	1200	DCLK
HS Pulse Width	thpw	1	-	40	DCLK
HS Blanking	thb	46	46	46	DCLK
HS Front Porch	thfp	16	210	354	DCLK

9.4.2 Vertical INPUT TIMING

ITEM	SYMBOL	MIN.	TYP.	MAX.	UNIT
Vertical Display Area	tvd	-	480	-	TH
VS Period time	tv	510	525	650	TH
VS Pulse Width	tvpw	1	-	20	TH
VS Blanking	tvb	23	23	23	TH
VS Front Porch	tvfp	7	22	147	TH

9.5 DATA INPUT FORMAT

9.5.1 HORIZONTAL INPUT TIMING DIAGRAM

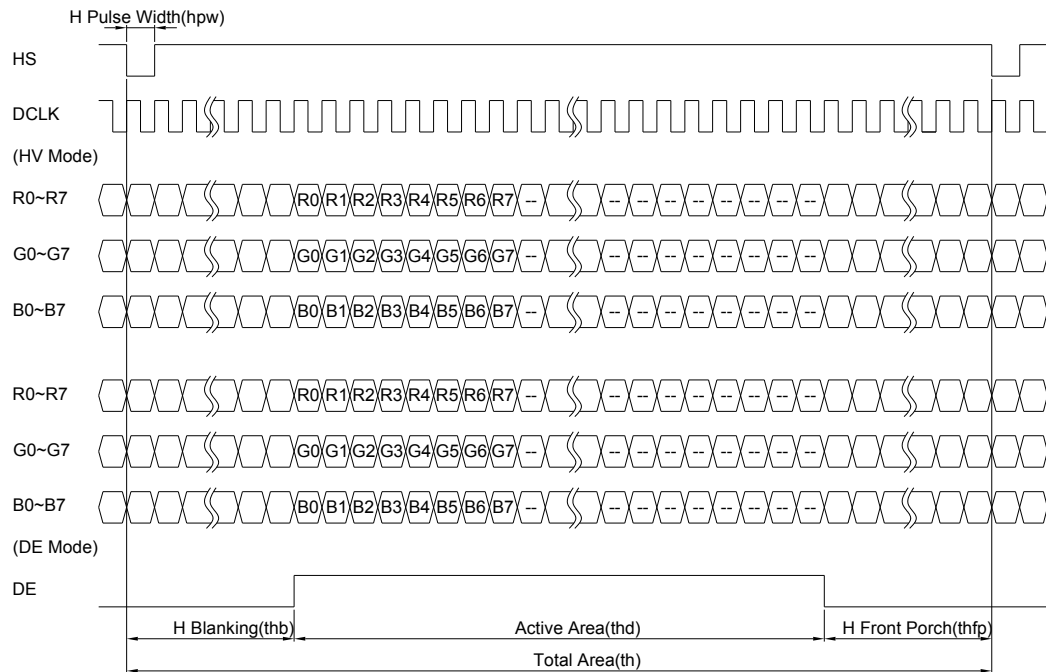

9.5.2 VERTICAL INPUT TIMING DIAGRAM

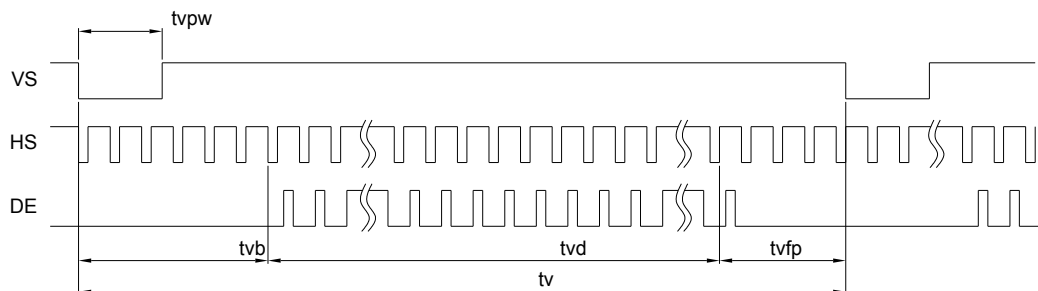

10. RELIABILITY TEST

ENVIRONMENTAL TEST				
NO.	ITEM	CONDITIONS	TIME PERIOD	REMARK
1	High Temperature Storage	85□	240HRS	
2	Low Temperature Storage	-30□	240HRS	
3	High Temperature Operation	85□	240HRS	
4	Low Temperature Operation	-30□	240HRS	
5	Temperature Cycle	-30□~85□	1HRS/ 100CYCLE	
6	High Temperature Humidity Storage	60□ 90%RH	240HRS	

NOTE 1 : a. The module should work properly.

b. Before and after function test, The difference of consumptive current. Should be within 10%.

NOTE 2 : a. The module should work properly.

b. The module won't be deformative, Color changeable or broken.

c. The modules can't be apart.

NOTE 3 : a. Before cosmetic and function test, The product must have enough recovery time, At least 2 hours at room temperature.

10.1 VIBRATION TEST :

10.1.1 STATE LABORATORY ENVIRONMENT :

Room temperature : $25\pm 3^{\circ}\text{C}$
Relative humidity : $55\pm 20\% \text{RH}$

10.1.2 TEST METHOD / SPECIFICATION :

Sample Status : Non-packaged single state
Waveform : Sine
Frequency : 10Hz~55Hz~10Hz
Full amplitude : 1.5mm
Vibration direction : X,Y,Z Axis (3 Axial)
Test time : Each 2Hour / X,Y,Z Axis , Altogether 6 Hour

10.2 MECHANICAL SHOCK TEST :

10.2.1 STATE LABORATORY ENVIRONMENT :

Room temperature : $25\pm 3^{\circ}\text{C}$
Relative humidity : $55\pm 20\% \text{RH}$

10.2.2 TEST METHOD / SPECIFICATION :

Sample Status : Non-packaged single state
Waveform : Half-sine
Acceleration : 100G
Shock Time : 6ms
Impact direction : 6 Directions ($\pm X, \pm Y, \pm Z$ axes)
Number of shocks : Each direction 3 Secondary , Altogether 18 Secondary

11.MODEL NUMBER SYSTEM

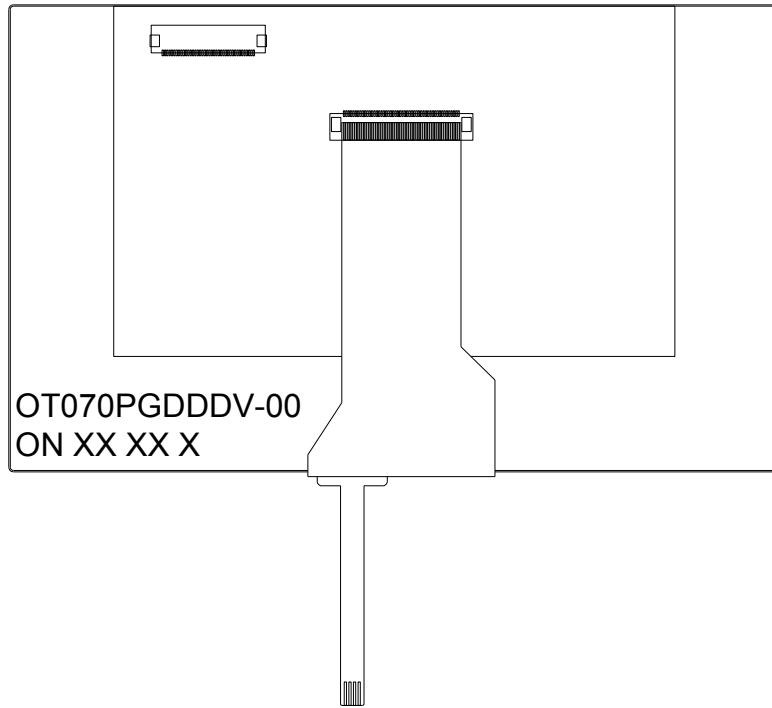

(a) MODEL NAME : OT070PGDDDV-00

(b) LOT NO : XX XX X

CODE	MEANING	DESCRIPTION
<u>XX</u>	Year	2013=13, 2014=14, 2015=15,
<u>XX</u>	Month	01,02,03,04,05,06,07,08,09,10,11,12
<u>X</u>	Week	1,2,3,4,5,6

12. LCM INSPECTION STANDARD

Inspection specifications refer ONation Corporation LCM INSPECTION STANDARD Document.
Document Number :QT3-QC-A-I002

13 PACKAGE INFORMATION

LCM Model	LCM Qty. in the box	Inner Box Size (mm)	Weight	REMARK
OT070PGDDDV-00	TBD	TBD	TBD	

14. PRECAUTIONS FOR USE

14.1 SAFETY

- (1) Do not swallow any liquid crystal, even if there is no proof that liquid crystal is poisonous.
- (2) If the LCD panel breaks, be careful not to get liquid crystal to touch your skin.
- (3) If skin is exposed to liquid crystal, wash the area thoroughly with alcohol or soap.

14.2 STORAGE CONDITIONS

- (1) Store the panel or module in a dark place where the temperature is $23\pm 5^{\circ}\text{C}$ and the humidity is below $50\pm 20\% \text{RH}$.
- (2) Store in anti-static electricity container.
- (3) Store in clean environment, free from dust, active gas, and solvent.
- (4) Do not place the module near organics solvents or corrosive gases.
- (5) Do not crush, shake, or jolt the module.

14.3 HANDLING PRECAUTIONS

- (1) Avoid static electricity which can damage the CMOS LSI.
- (2) The polarizing plate of the display is very fragile. So, please handle it very carefully.
- (3) Do not give external shock.
- (4) Do not apply excessive force on the surface.
- (5) Do not wipe the polarizing plate with a dry cloth, as it may easily scratch the Surface of plate.
- (6) Do not use ketonics solvent & Aromatic solvent, use with a soft cloth soaked with a cleaning naphtha solvent.
- (7) Do not operate it above the absolute maximum rating.
- (8) Do not remove the panel or frame from the module.
- (9) When the module is assembled, it should be attached to the system firmly, Be careful not to twist and bend the module.
- (10) Wipe off water droplets or oil immediately . If you leave the droplets for a long time, staining and discoloration may occur.
- (11) If the liquid crystal material leaks from the panel, it should be kept away from the eyes or mouth. In case of contact with hands, legs or clothes, it must be washed away thoroughly with soap.

14.4 WARRANTY

- (1) Acceptance inspection period
The period is within one month after the arrival of contracted commodity at the buyer's factory site.
- (2) Applicable warrant period
The period is within 12 months since the date of shipping out under normal using and storage conditions.