

TFT-DISPLAY DATASHEET

ONation
Model: OT101CAWDLT-00

BRIEF SPEC.:

Main Feature	Landscape Type White LED Backlight Wide Viewing Angle
Active Screen Area	222.72 x 125.28 (mm)
Diagonal Format	10,1" 16:9
Resolution	1024 x 600
Colors	R.G.B Stripe
Backlight	LED, White
Brightness	330 cd/m ²
LED Life Time	50,000h (Typ.)
Interface	LVDS
Viewing Angle	-70~80(H), -70~80(V)
Touchscreen	Yes
Power Supply	3,3V (Typ.)
Module Outline	224 x 143 x 13.8 (mm)
Operation Temperature	-30... +80 °C
Storage Temperature	-30... +85 °C
Surface Treatment	N/A



ONation Corporation

TFT COLOR LCD MODULE

MODEL: OT101CAWDLT-00

WSVGA
LVDS interface

Version: P0.1

Customer : _____
Approved By : _____
Date: _____

ONATION		
APPROVAL	CHECKER	PREPARE
<i>Ian</i>	<i>Josh</i>	<i>Aiden</i>

[All information is subject to change without notice.](#)
[Please confirm the sales representative before starting to design your system](#)

CONTENTS

NO.	ITEM	PAGE
1	RECORD OF REVISION	0-1
2	MECHANICAL SPECIFICATIONS	1
3	OUTLINE DIMENSIONS	2
4	INTERFACE PIN CONNECTION	3
5	BLOCK DIAGRAM	4
6	ABSOLUTE MAXIMUM RATINGS	4
7	ELECTRICAL CHARACTERISTICS	5
8	OPTICAL CHARACTERISTICS	6~8
9	TOUCH PANEL SPECIFICATIONS	9
10	TIMING SPECIFICATIONS	10~11
11	RELIABILITY TEST	12~13
12	MODEL NUMBER SYSTEM	14
13	LCM INSPECTION STANDARD	15
14	PACKAGE INFORMATION	15
15	PRECAUTIONS FOR USE	16

1.RECORD OF REVISION

REV	DATE	PAGE	SUMMARY
0.1	2014.03.06	ALL	Preliminary specification was first issued.

2.MECHANICAL SPECIFICATIONS

(1)	Number Of Dots (Dots)	1024(R.G.B) X 600
(2)	Module Size(mm)	244.0(H) X 143.0(V) X 138(D) (**)
(3)	Active Area(mm)	222.72(H) X 125.28(V)
(4)	Pixel Pitch(mm)	0.2175 (H) X 0.2088(V)
(5)	LCD / Polarizer Model	TFT , Transmissive, Normally/White
(6)	Backlight Color	White, LED
(7)	Viewing Direction	Wide View Angle Horizontal : Right side 80°(typ.), Left side 80°(typ.) Vertical : Up side 80°(typ.), Down side 80°(typ.)
(8)	Gray Scale Inversion Direction	NO GSI
(9)	Electrical Interface	LVDS Interface
(10)	Color Configuration	R.G.B Stripe
(11)	Module Weight(g)	TBD

(**)Module include PCB and component.

3. OUTLINE DIMENSIONS

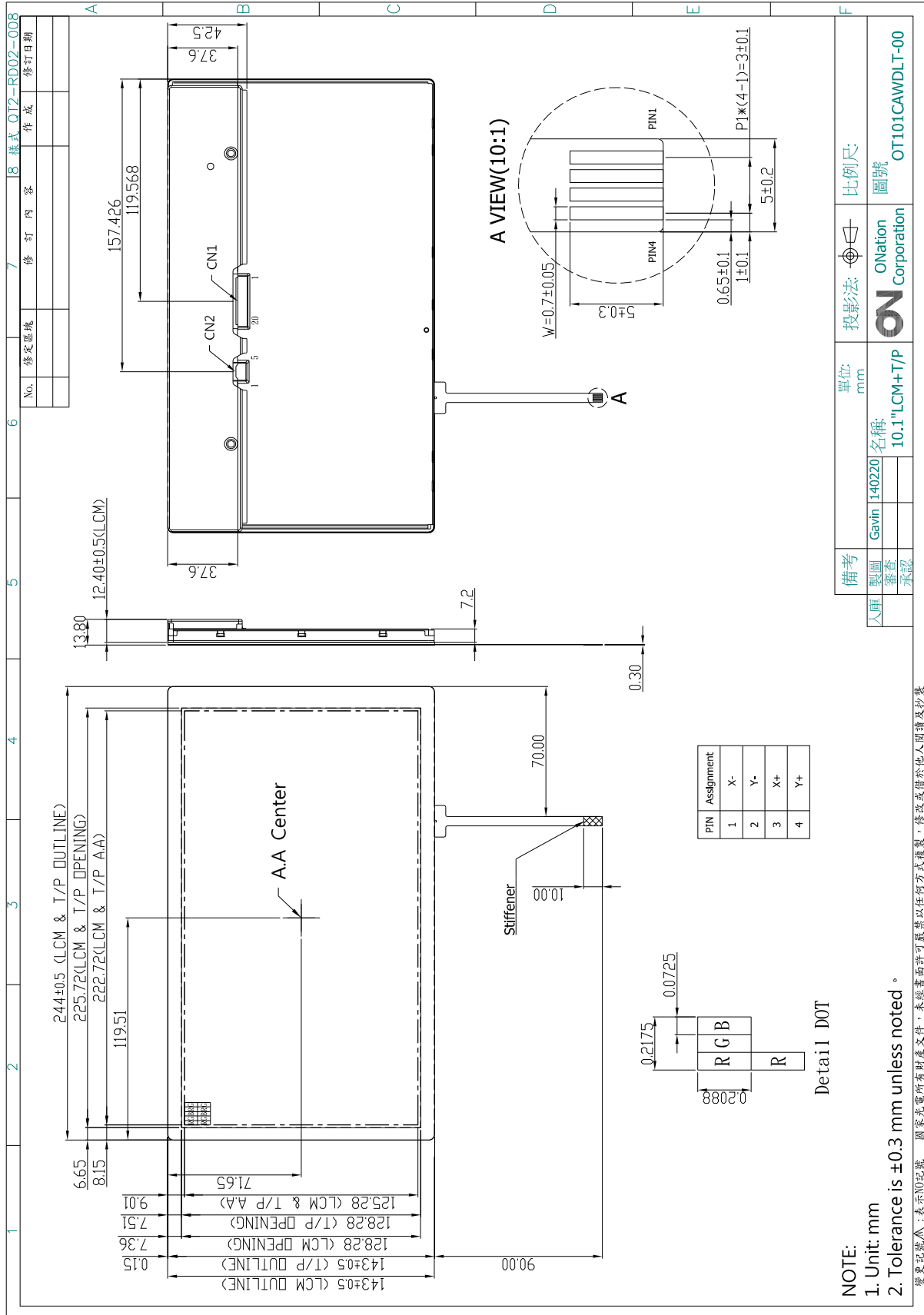

4. INTERFACE PIN CONNECTION

4.1 LCM PANEL DRIVING SECTION

CN1:STM MSB240420HD or equivalent

PIN NO.	SIGNAL	FUNCTION
1	VCC	Digital Power
2	VCC	Digital Power
3	GND	Ground
4	REV	Reverse Scan Selection
5	RxIN0-	Differential Clock Input,CH0(Negative)
6	RxIN0+	Differential Clock Input,CH0(Positive)
7	GND	Ground
8	RxIN1-	Differential Clock Input,CH1(Negative)
9	RxIN1+	Differential Clock Input,CH1(Positive)
10	GND	Ground
11	RxIN2-	Differential Clock Input,CH2(Negative)
12	RxIN2+	Differential Clock Input,CH2(Positive)
13	GND	Ground
14	RxCLKIN-	Differential Clock Input (Negative)
15	RxCLKIN+	Differential Clock Input (Positive)
16	GND	Ground
17	RxIN3-	Differential Clock Input,CH3(Negative)
18	RxIN3+	Differential Clock Input,CH3(Positive)
19	SEL68	6/8 bits LVDS data input selection(H:8bit;L/Floating:6bit)
20	NC	No connection

4.2 BACKLIGHT PANEL DRIVING SECTION

CN2:STM MSB24038P5A or equivalent

PIN NO.	SIGNAL	FUNCTION
1	VLED	Power Supply for LED Driver Circuit(12V)
2	GND	Ground
3	EN	3.3V(TYP.)
4	PWM	3.3V(TYP.)
5	NC	No connection

4.3 T/P PANEL DRIVING SECTION

PITCH=1.0mm,4PIN

PIN NO.	SIGNAL	FUNCTION
1	X-	Touch panel(X-Left)
2	Y-	Touch panel(Y-Bottom)
3	X+	Touch panel(X-Right)
4	Y+	Touch panel(Y-Top)

5. BLOCK DIAGRAM

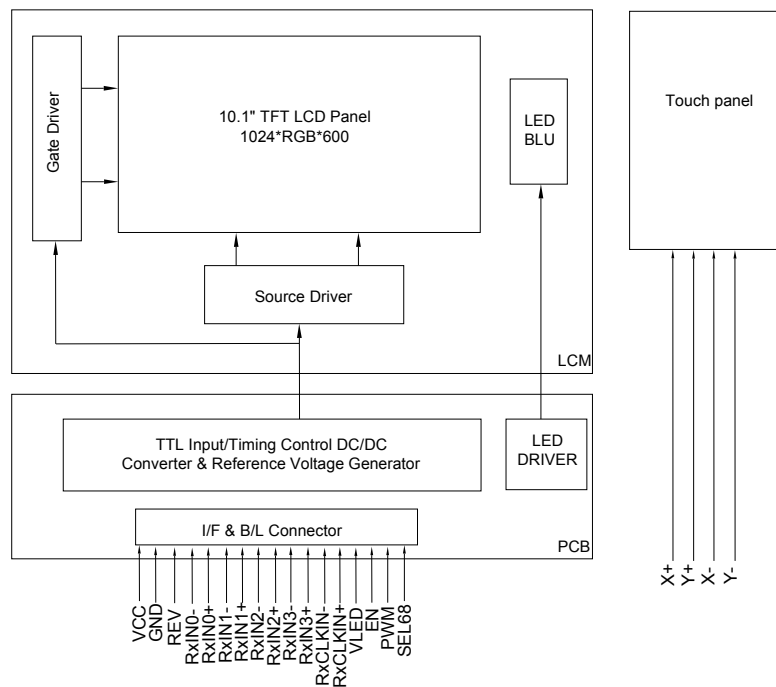

6. ABSOLUTE MAXIMUM RATINGS

6.1 ELECTRICAL ABSOLUTE MAXIMUM RATINGS

ITEM	SYMBOL	MIN.	MAX.	UNIT	REMARK
Supply Voltage	VCC	-0.3	+3.6	V	
	VLED	8	16	V	
PWM Dimming Voltage	VPWM	0.8	5.0	V	
Enable	VEN	0	5	V	

6.2 ENVIRONMENTAL ABSOLUTE MAXIMUM RATINGS

ITEM	OPERATING		STORAGE		REMARK
	MIN.	MAX.	MIN.	MAX.	
Ambient Temperature(°C)	-30	80	-30	85	Note 1,2
Humidity(% RH)	Note 3		Note 3		Without condensation

Note 1 : The response time will become lower when operated at low temperature.

Note 2 : Background color changes slightly depending on ambient temperature.

Note 3 : $T_a \leq 50^\circ\text{C}$: 85%RH max , without condensation.

$T_a > 50^\circ\text{C}$: Absolute humidity shall be less than the value of 85%RH at 50°C without condensation

7. ELECTRICAL CHARACTERISTICS

7.1 ELECTRICAL CHARACTERISTICS OF LCD

Ta=25°C

ITEM	SYMBOL	MIN.	TYP.	MAX.	UNIT	REMARK
Power Voltage For LCD	VCC	3.0	3.3	3.6	V	
	ICC	-	-	191	mA	Note 1
REV	VH	2.0	3.3	5.0	V	
	VL	-	-	0.8	V	

Note 1 : Test condition : VCC=3.3V ; Test Pattern : All Black.

7.2 BACKLIGHT UNITS

Ta=25°C

ITEM	SYMBOL	MIN.	TYP.	MAX.	UNIT	REMARK
LED Driving Voltage	VLED	8	12	16	V	
	ILED	-	-	543	mA	
Brightness Control	VIH	2	3.3	5	V	Note1
	VIL	0	-	0.8	V	Note1
PWM Frequency	FPWM	100	-	1K	Hz	Note1
Duty	-	5	-	100	%	Note1
LED Life Time	-	50000	-	-	Hr	Note2

Note1:

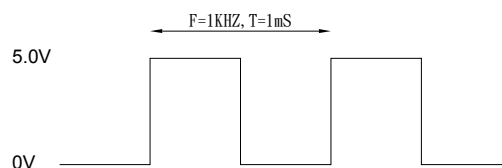
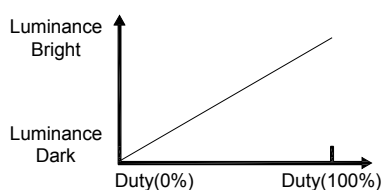

Note2: The LED life time define as the estimated time to 50% degradation of the initial value.

8. OPTICAL CHARACTERISTICS

Ta=25°C

ITEM	SYMBOL	CONDITIONS	MIN.	TYP.	MAX.	UNIT	REMARK
Contrast Ratio	CR	Viewing Normal Angle $\Theta_x=\Theta_y=0^\circ$	400	500	-	-	Note 1
Response Time	TR+TF		-	16	20	ms	Note 2
Chromaticity	White	Wx	0.262	0.312	0.362	-	Note 4
		Wy	0.292	0.342	0.392	-	
Viewing Angle	Hor.	θ_{x+}	(70)	(80)	-	Deg.	Note 3
		θ_{x-}	(70)	(80)	-		
	Ver.	θ_{y+}	(70)	(80)	-		
		θ_{y-}	(70)	(80)	-		
Luminance	L	PWM=100%	300	330	-	cd/m2	
Luminance Uniformity	YU	PWM=100%	75	80	-	%	Note 5

Note 1 : Definition of Contrast Ratio (CR) :

The contrast ratio can be calculated by the following expression.

$$\text{Contrast Ratio (CR)} = L63/L0$$

L63 : Luminance of gray level 63

L0 : Luminance of gray level 0

$$CR = CR(5)$$

CR(X) is corresponding to the Contrast Ratio of the point X at Figure in Note 5

Note 2 : Definition of Response Time (TR.TF)

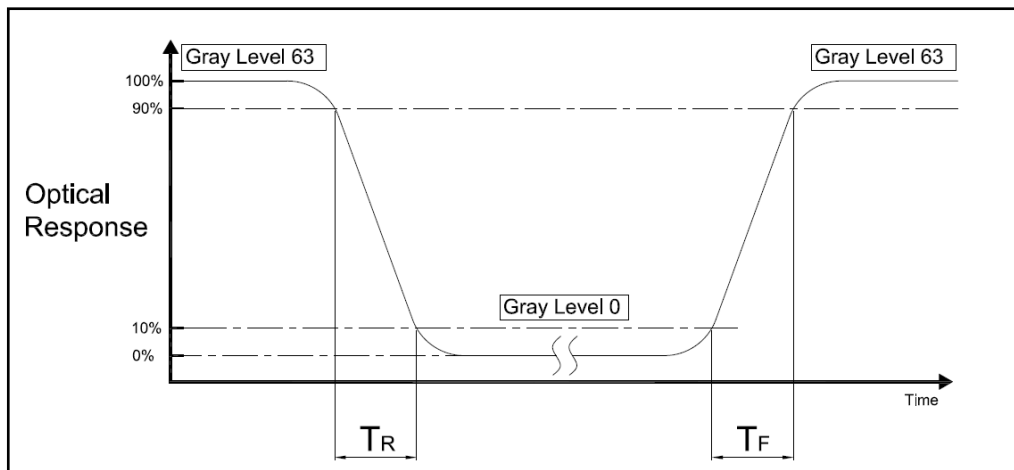

Note 3 : Definition of Viewing Angle

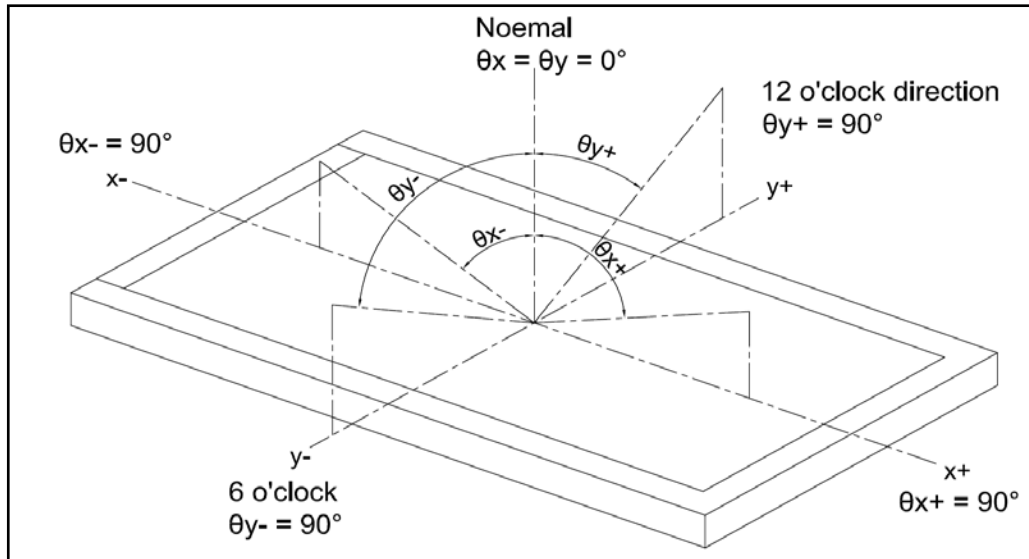

Note 4 : Measurement Set-Up:

The LCD module should be stabilized at a given temperature for 20 minutes to avoid abrupt temperature change during measuring. In order stabilize the luminance, the measurement should be executed after lighting Backlight for 20 minutes in a windless room.

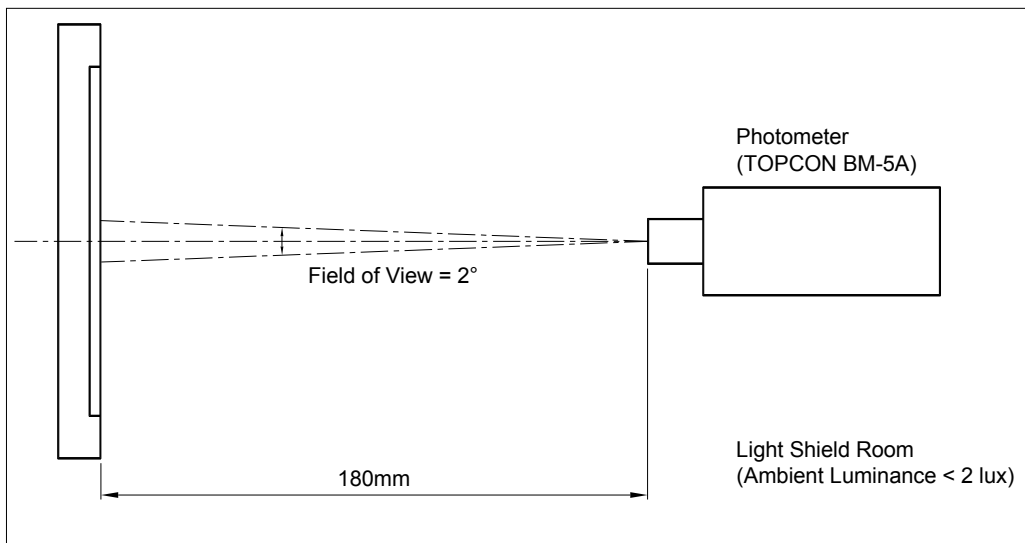

Note 5 :

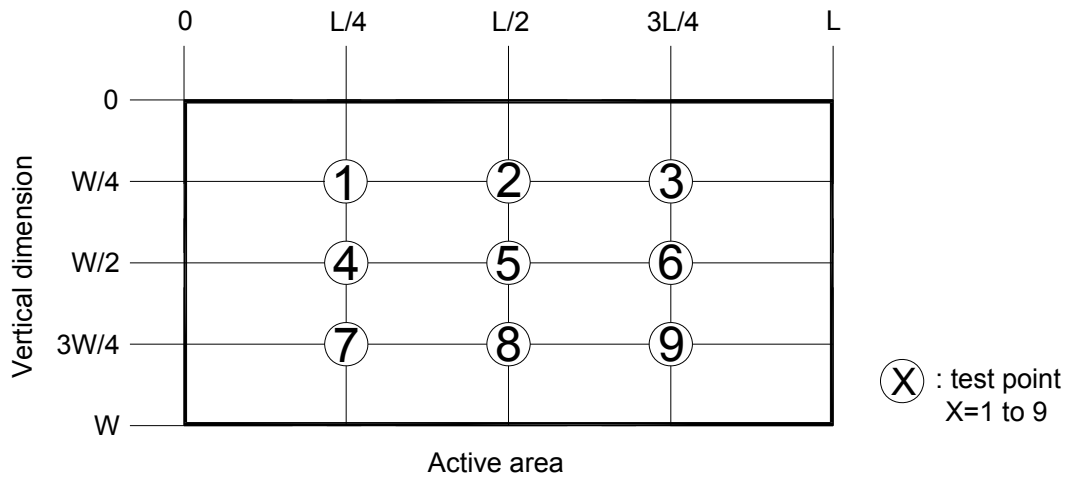

$$\left(1 - \frac{\text{MAX Luminance} - \text{Average Luminance}}{\text{Average Luminance}} \right) \times 100\% \geq 75\%$$

9. TOUCH PANEL SPECIFICATIONS

ITEM	SPECIFICATIONS	REMARK
Working Voltage	DC 5V	
Resistance	X axis:400~1100 Ω	
Resistance	Y axis:200~650 Ω	
Linearity	$\leq 2.0\%$	
Response	$\leq 15\text{ms}$	
Operation force	30g~150g Max.	
Insulation Impedance	25V(DC) $\geq 20\text{M}\Omega$	

10. TIMING SPECIFICATIONS

10.1 POWER ON/OFF SEQUENCE

ITEM	SYMBOL	MIN.	TYP.	MAX.	UNIT	REMARK
VCC rising Time from 10% to 90%	T1	0.5	-	10	ms	
Delay from VCC to valid data at power ON	T2	0	-	50	ms	
Delay from valid data OFF to VCC OFF at power OFF	T3	0	-	50	ms	
VCC OFF time for Windows restart	T4	500	-	-	ms	
Delay from valid data to B/L enable at power ON	T5	200	-	-	ms	
Delay from valid data off to B/L disable at power OFF	T6	200	-	-	ms	
VCC falling time from 90% to 10%	T7	0	-	10	ms	
LED Vin rising time from 10% to 90%	T8	0.5	-	10	ms	
LED Vin falling time from 90% to 10%	T9	0.5	-	10	ms	
Delay from LED driver Vin rising time 90% to PWM ON	T10	0	-	10	ms	
Delay from PWM Off to LED Driver Vin falling time 10%,Must Keep rule	T11	0	-	-	ms	
Delay from PWM ON to B/L Enable ON, Must Keep rule	T12	0	-	-	ms	
Delay from B/L Enable Off to PWM Off	T13	0	-	-	ms	

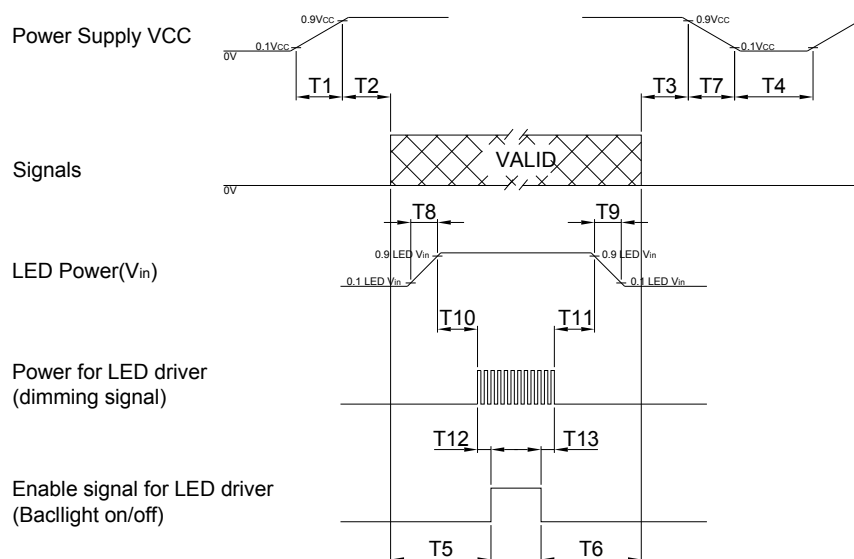

10.2 TIMING CHARACTERISTICS

Synchronization Method : DE only

ITEM	SYMBOL	MIN.	TYP.	MAX.	UNIT	REMARK
LVDS Clock Frequency (single)	fdck	45	51.2	57	MHz	
H Total Time	Thp	1324	1344	1364	clocks	
H Active Time	HA	1024	1024	1024	clocks	
H Blanking Time	THBLANK	300	320	340	clocks	
V Total Time	TVP	625	635	645	lines	
V Active Time	VA	600	600	600	lines	
V Blanking Time	TVBLANK	25	35	45	lines	
V Frequency	fv	55	60	65	Hz	

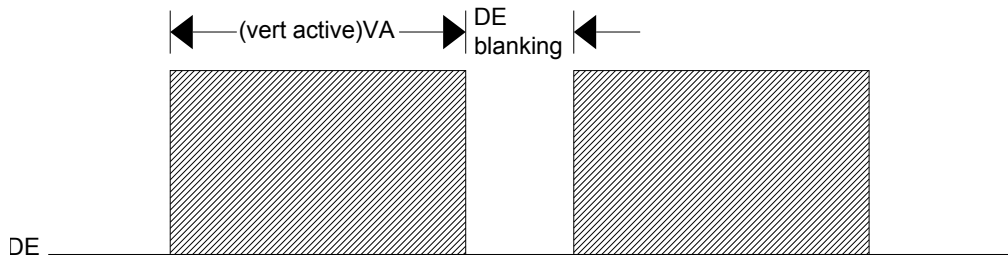

10.3 TIMING DIAGRAM OF INTERFACE SIGNAL

6bit LVDS input

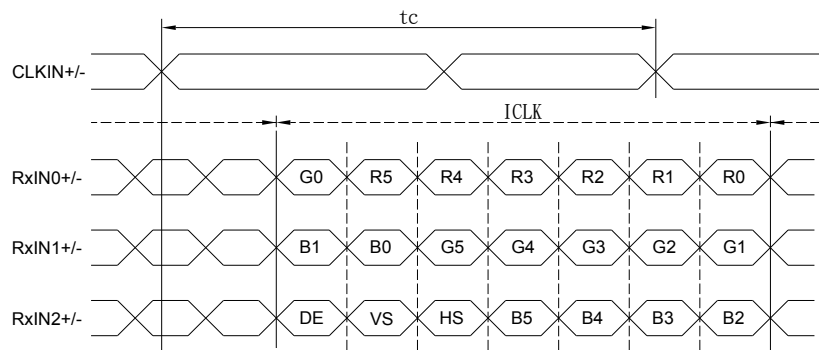

8bit LVDS input

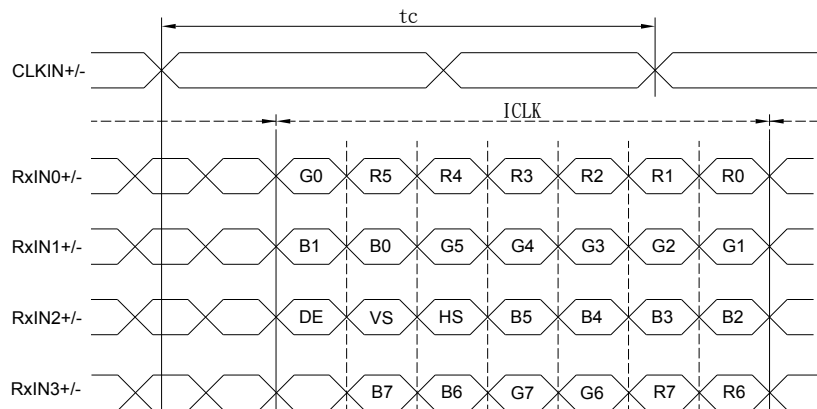

11. RELIABILITY TEST

ENVIRONMENTAL TEST				
NO.	ITEM	CONDITIONS	TIME PERIOD	REMARK
1	High Temperature Storage	(85°C)	72HRS	
2	Low Temperature Storage	(-30°C)	72HRS	
3	High Temperature Operation	(80°C)	72HRS	
4	Low Temperature Operation	(-30°C)	72HRS	
5	High Temperature Humidity Storage	(+50°C) (85%RH)	72HRS	

Note 1: a. The module should work properly.

b. Before and after function test, The difference of consumptive current. Should be within 10%

Note 2: a. The module should work properly.

b. The modlue won't be deformative, Color changeable or broken.

c. The modules can't be apart.

Note 3: a. Before cosmetic and function test, The product must have enough recovery time, At least 2 hours at room temperature.

11.1 VIBRATION TEST :

11.1.1 STATE LABORATORY ENVIRONMENT :

Room temperature : $25\pm 3^{\circ}\text{C}$
Relative humidity : $55\pm 20\% \text{RH}$

11.1.2 TEST METHOD / SPECIFICATION :

Sample Status : Non-packaged single state
Waveform : Sine
Frequency : 10~55~10Hz
Full amplitude : 1.5mm
Vibration direction : X,Y,Z Axis (3 Axial)
Test time : Each 2Hour / X,Y,Z Axis , Altogether 6 Hour

11.2 MECHANICAL SHOCK TEST :

11.2.1 STATE LABORATORY ENVIRONMENT :

Room temperature : $24\pm 3^{\circ}\text{C}$
Relative humidity : $55\pm 20\% \text{RH}$

11.2.2 TEST METHOD / SPECIFICATION :

Sample Status : Non-packaged single state
Waveform : Half-sine
Acceleration : 100G
Shock Time : 6ms
Impact direction : 6 Directions ($\pm X$, $\pm Y$, $\pm Z$ axes)
Number of shocks : Each direction 3 Secondary , Altogether 18 Secondary

12.MODEL NUMBER SYSTEM

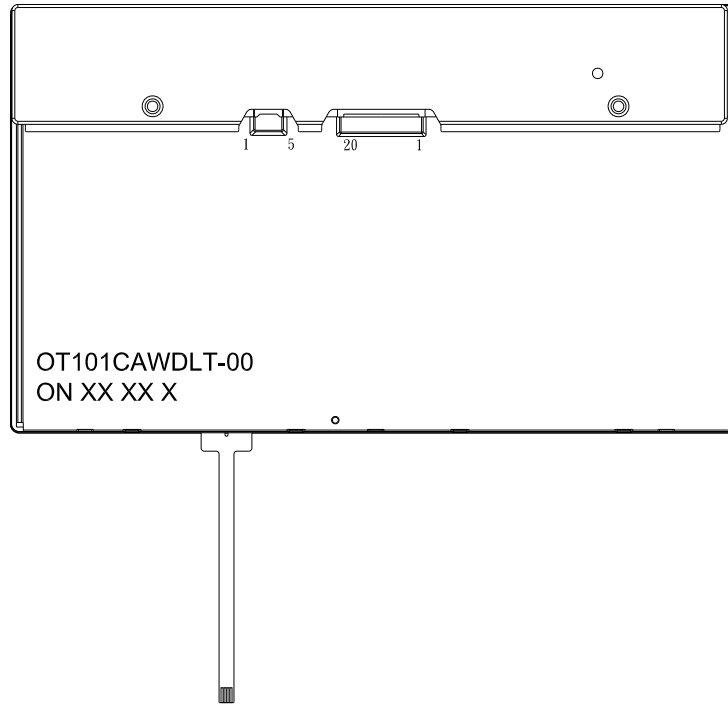

(a) MODEL NAME : OT101CAWDLT-00

(b) LOT NO : XX XX X

CODE	MEANING	DESCRIPTION
<u>XX</u>	Year	2013=13, 2014=14, 2015=15,
<u>XX</u>	Month	01,02,03,04,05,06,07,08,09,10,11,12
<u>X</u>	Week	1,2,3,4,5,6

13. LCM INSPECTION STANDARD

Inspection specifications refer ONation Corporation LCM INSPECTION STANDARD Document.
Document Number : QT3-QC-A-I003

14. PACKAGE INFORMATION

LCM MODEL	LCM QTY. IN THE BOX	INNER BOX SIZE(mm)	WEIGHT	REMARK
OT101CAWDLT-00	TBD	TBD	TBD	

15.PRECAUTIONS FOR USE

15.1 SAFETY

- (1) Do not swallow any liquid crystal, even if there is no proof that liquid crystal is poisonous.
- (2) If the LCD panel breaks, be careful not to get liquid crystal to touch your skin.
- (3) If skin is exposed to liquid crystal, wash the area thoroughly with alcohol or soap.

15.2 STORAGE CONDITIONS

- (1) Store the panel or module in a dark place where the temperature is $23\pm 5^{\circ}\text{C}$ and the humidity is below $50\pm 20\%\text{RH}$.
- (2) Store in anti-static electricity container.
- (3) Store in clean environment, free from dust, active gas, and solvent.
- (4) Do not place the module near organics solvents or corrosive gases.
- (5) Do not crush, shake, or jolt the module.

15.3 HANDLING PRECAUTIONS

- (1) Avoid static electricity which can damage the CMOS LSI.
- (2) The polarizing plate of the display is very fragile. So, please handle it very carefully.
- (3) Do not give external shock.
- (4) Do not apply excessive force on the surface.
- (5) Do not wipe the polarizing plate with a dry cloth, as it may easily scratch the Surface of plate.
- (6) Do not use ketonics solvent & Aromatic solvent, use with a soft cloth soaked with a cleaning naphtha solvent.
- (7) Do not operate it above the absolute maximum rating.
- (8) Do not remove the panel or frame from the module.
- (9) When the module is assembled, it should be attached to the system firmly, Be careful not to twist and bend the module.
- (10) Wipe off water droplets or oil immediately . If you leave the droplets for a long time, staining and discoloration may occur.
- (11) If the liquid crystal material leaks from the panel, it should be kept away from the eyes or mouth. In case of contact with hands, legs or clothes, it must be washed away thoroughly with soap.

15.4 WARRANTY

- (1) Acceptance inspection period
The period is within one month after the arrival of contracted commodity at the buyer's factory site.
- (2) Applicable warrant period
The period is within 12 months since the date of shipping out under normal using and storage conditions.