

TFT-DISPLAY DATASHEET

ONation
Model: OT101CBWDLT-05

BRIEF SPEC.:

Main Feature

Landscape
Touchscreen

Active Screen Area	216.9 x 135.6 (mm)
Diagonal Format	10,1" 16:10
Resolution	1280 X 800
Colors	262K/16.7M (6Bit)
Backlight	LED
Brightness	480 cd/m ²
LED Life Time	50K(h)
Interface	LVDS
Viewing Angle	85/85 L/R 85/85
Touchscreen	Yes
Power Supply	3.3 V
Module Outline	252 x 172.6 x 10.43 (mm)
Operation Temperature	-20 ... +70 °C
Storage Temperature	-30... +80 °C



ONation Corporation

TFT COLOR LCD MODULE

MODEL: OT101CBWDLT-05

(Complied with RoHS)

WXGA

LVDS interface(1 Port)

Version: P0.1

Customer : _____
Approved By : _____
Date: _____

ONATION		
APPROVAL	CHECKER	PREPARE
		Josh

All information is subject to change without notice.
Please confirm the sales representative before starting to design your system

CONTENTS

NO.	ITEM	PAGE
1	RECORD OF REVISION	0-1
2	MECHANICAL SPECIFICATIONS	1
3	OUTLINE DIMENSIONS	2
4	INTERFACE PIN CONNECTION	3~4
5	BLOCK DIAGRAM	5
6	ABSOLUTE MAXIMUM RATINGS	6
7	ELECTRICAL CHARACTERISTICS	7
8	OPTICAL CHARACTERISTICS	8 ~10
9	TOUCH PANEL SPECIFICATIONS	11
10	TIMING SPECIFICATIONS	12~15
11	RELIABILITY TEST	16
12	LCM INSPECTION STANDARD	17
13	PACKAGE INFORMATION	17
14	PRECAUTIONS FOR USE	18

2.MECHANICAL SPECIFICATIONS

(1)	Number Of Dots (Dots)	1280R.G.B X 800
(2)	Module Size(mm)	252(W) X172.6(H) X 10.43 (D)
(3)	Active Area(mm)	216.96(W) X135.60(H)
(4)	Pixel Pitch(mm)	0.1695(W) X0.1695(H)
(5)	LCD / Polarizer Model	TFT , Transmissive Normally Black
(6)	LED Backlight Color	White
(7)	Viewing Direction	Wide viewing angle Horizontal :Right side 85°(Typ),Left side85°(Typ) Vertical: Up side 85°(Typ),Down side 85°(Typ)
(8)	Gray Scale Inversion Direction	NO GSI
(9)	Color Configuration	R.G.B Vertical Stripe
(10)	Interface	LVDS
(11)	Module Weight(g)	TBD

3. OUTLINE DIMENSIONS

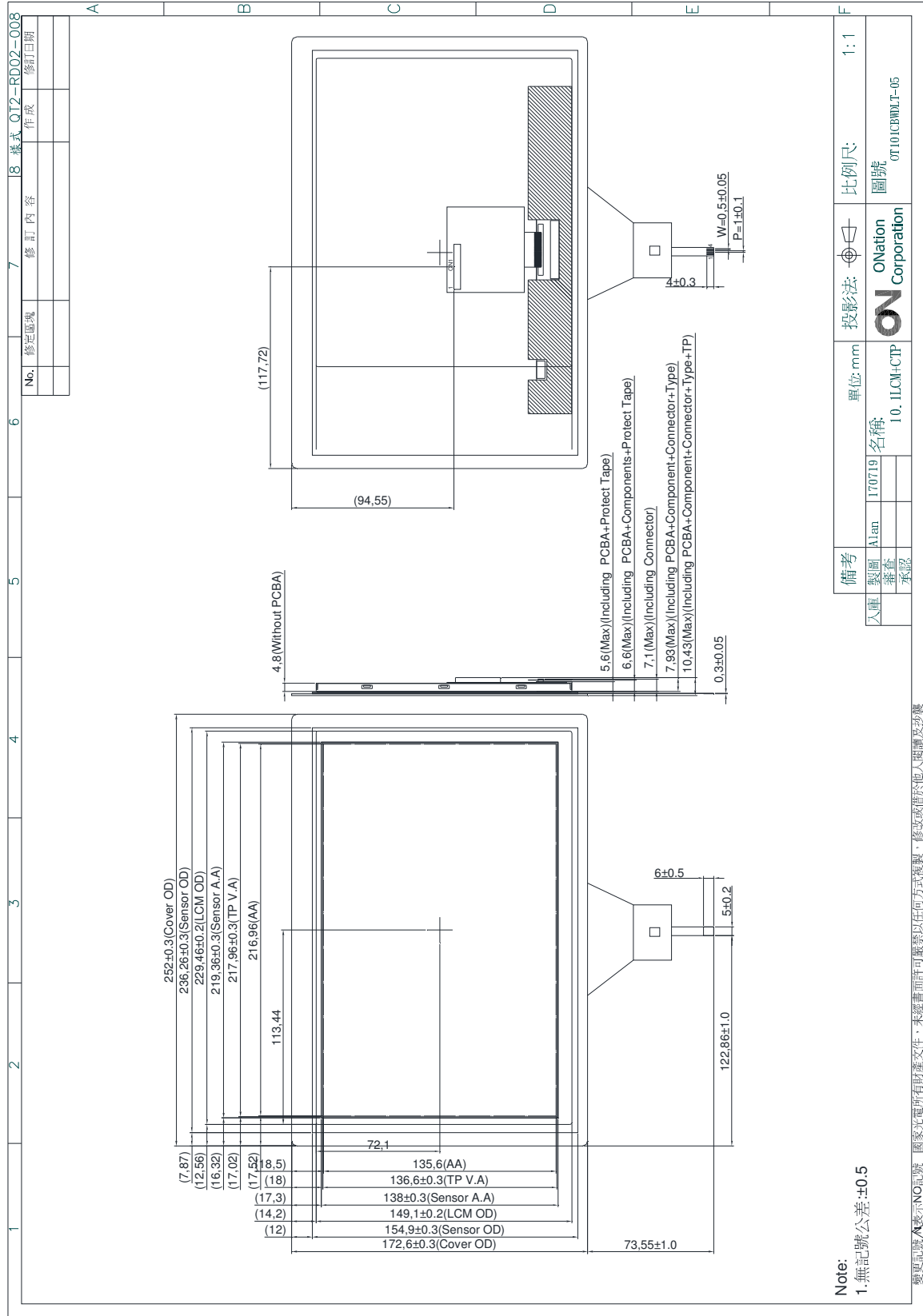

變更記號表示NO記號 國家光電所有財產文件，未經書面許可嚴禁以任何方式複製、修改或借於他人閱讀及抄襲

4. INTERFACE PIN CONNECTION

CN1 Connector : I-PEX 20455-040E-12 or Equivalen

PIN NO.	SIGNAL	FUNCTION
1	VCC	Power Supply For Digital Circuit
2	VCC	Power Supply For Digital Circuit
3	VCC	Power Supply For Digital Circuit
4	NC	Non Connection (open)
5	NC	Non Connection (open)
6	NC	Non Connection (open)
7	NC	Non Connection (open)
8	RxIN0-	Differential Data Input, CH0(Negative)
9	RxIN0+	Differential Data Input, CH0(Positive)
10	GND	Ground
11	RxIN1-	Differential Data Input, CH1(Negative)
12	RxIN1+	Differential Data Input, CH1(Positive)
13	GND	Ground
14	RxIN2-	Differential Data Input, CH2(Negative)
15	RxIN2+	Differential Data Input, CH2(Positive)
16	GND	Ground
17	CLKIN-	Differential Clock Input(Negative)
18	CLKIN+	Differential Clock Input(Positive)
19	GND	Ground
20	RxIN3-	Differential Data Input, CH3(Negative)
21	RxIN3+	Differential Data Input, CH3(Positive)
22	GND	Ground
23	NC	Non Connection (open)
24	NC	Non Connection (open)
25	GND	Ground
26	GND	Ground
27	PWM	PWM Control Signal od LED Converter
28	EN	Enable Control Signal od LED Converter
29	VSS	LED Ground
30	VSS	LED Ground
31	VSS	LED Ground
32	VSS	LED Ground
33	VSS	LED Ground

PIN NO.	SIGNAL	FUNCTION
34	NC	Non Connection (open)
35	NC	Non Connection (open)
36	VLED	LED Power Supply
37	VLED	LED Power Supply
38	VLED	LED Power Supply
39	VLED	LED Power Supply
40	VLED	LED Power Supply

4.2 TOUCH PANEL PIN ASSIGNMENT

PITCH=0.5mm,4 PIN

PIN NO.	SIGNAL	FUNCTION
1	VDD	CTP Supply voltage
2	D-	Data -
3	D+	Data -
4	GND	Ground

5. BLOCK DIAGRAM

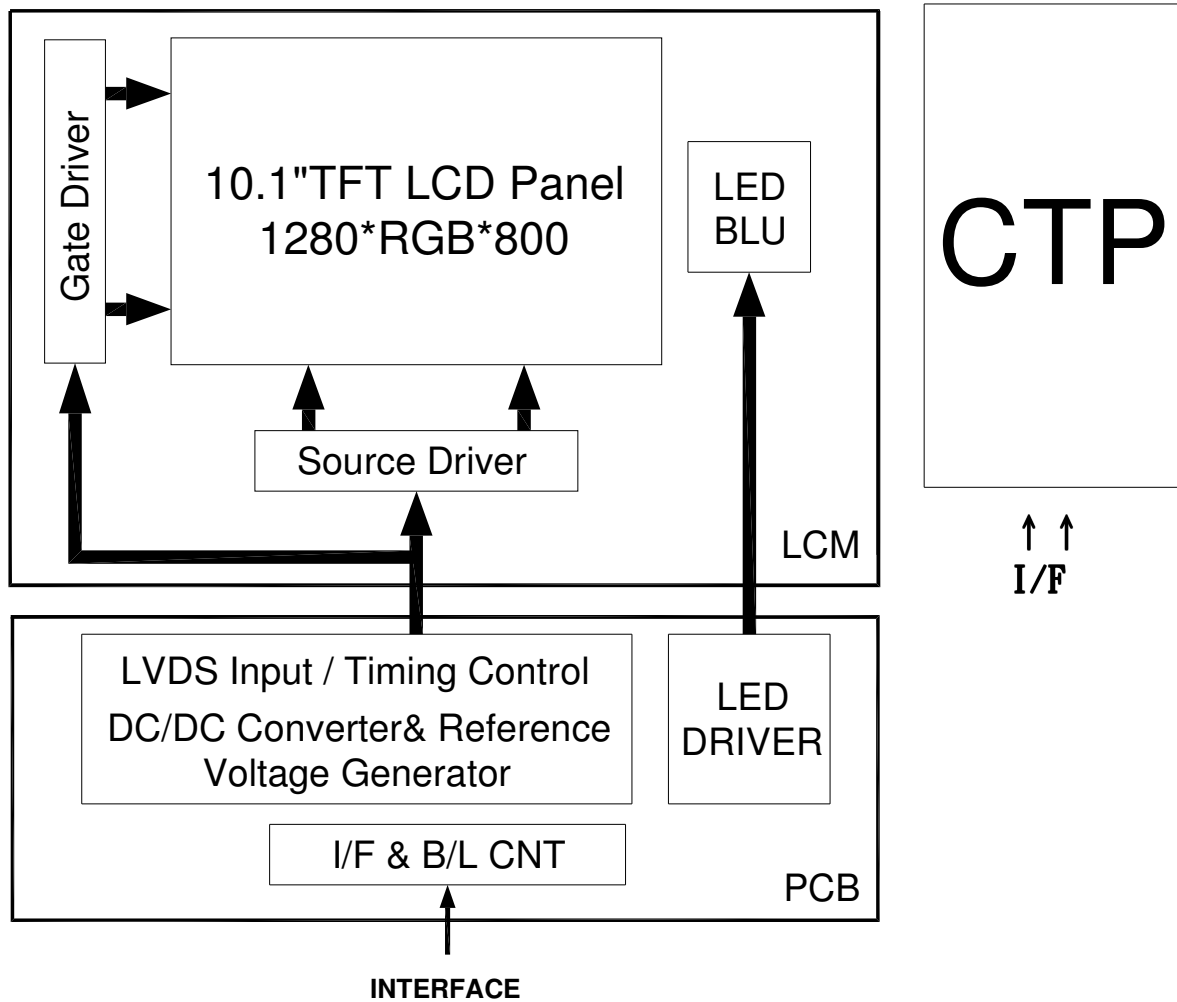

6.ABSOLUTE MAXIMUM RATINGS

6.1 ELECTRICAL ABSOLUTE MAXIMUM RATINGS

ITEM	SYMBOL	MIN.	MAX.	UNIT	REMARK
Supply Voltage	VCC	-0.3	+3.9	V	
	VLED	-4.5	+36	V	

Note: The absolute maximum rating values of this product not allowed to be exceeded at any times. Should be module be used with any of absolute maximum ratings exceeded. The characteristics of the module may not be recovered, or in an extreme case, the module may be permanently destroyed.

6.2 ENVIRONMENTAL ABSOLUTE MAXIMUM RATINGS

ITEM	OPERATING		STORAGE		REMARK
	MIN.	MAX.	MIN.	MAX.	
Ambient Temperature(°C)	-20	70	-30	80	Note 1,2
Humidity(% RH)	5 ~ 90		5 ~ 90		Note 3

Note 1 : The response time will become lower when operated at low temperature.

Note 2 : Background color changes slightly depending on ambient temperature.

Note 3 : Storage Ta=40°C & RH=90% ≤ 240Hrs.

7.ELECTRICAL CHARACTERISTICS

7.1 ELECTRICAL CHARACTERISTICS OF LCD

Ta=25°C

ITEM	SYMBOL	MIN.	TYP.	MAX.	UNIT	REMARK
Power Voltage For LCD	VCC	2.5	3.3	(3.6)	V	
	ICC	-	240	300	mA	Note 1
Differential Input Threshold Voltage	VIH	0.8VCC	-	VCC	mV	
	VIL	0	-	0.2VCC	mV	

Note 1 : Test condition : VCC=3.3V ; Test Pattern : White

7.2 BACKLIGHT UNITS

Ta=25°C

ITEM		SYMBOL	MIN.	TYP.	MAX.	UNIT
LED Driving Voltage		VLED	5.0	12.0	13.2	V
		ILED (VLED=12.0V)	-	(460)	(600)	mA
PWM Control Level	PWM High Level	-	3.0	3.3	3.6	V
	PWM Low Level	-	0	-	1.0	V
PWM Control Duty Ratio		-	0	-	100	%
PWM Control Frequency		f _{PWM}	100	-	2000	Hz
LED Life Time (For Reference Only)		Ta=25°C 60-70%RH (Note 1)	-	50000	-	Hr

Note 1: The LED of B/L is drive by current only, drive voltage is for reference only. drive voltage can make driving current under safety area(current between minimum and maximum). 50,000 hours is only an estimate for reference.

Note 2: The lifetime of LED is defined as the time when it continues to operate under the conditions at Ta= 25 ±2°C and PWM = 100% (LED forward current) until the brightness becomes ≤ 50% of its original value.

Note 3: ADJ signal Vp-p =3.0 ~ 3.6 V, operation frequency: 100Hz ~ 2000Hz:

PWM DIMMING DUTY

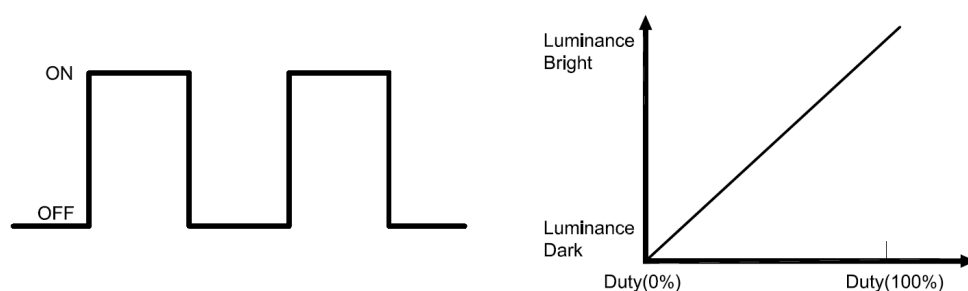

8.OPTICAL CHARACTERISTICS

Ta=25°C

ITEM		SYMBOL	CONDITIONS	MIN.	TYP.	MAX.	UNIT	REMARK
Contrast Ratio		CR	Viewing Normal Angle $\Theta_x=\Theta_y=0^\circ$	(600)	(800)	-	-	Note 1
Response Time		TR+TF		-	25	50	ms	Note 2
Color chromaticity	White	x	Viewing Angle $\Theta_x=\Theta_y=0^\circ$ $CR \geq 10$	(0.26)	(0.31)	(0.36)	-	Note 3
		y		(0.27)	(0.32)	(0.37)	-	
Viewing Angle	Hor.	θ_L		75	85	-	Deg.	
		θ_R		75	85	-		
	Ver.	θ_T	75	85	-			
		θ_B	75	85	-			
Luminance		L	PWM=100%	(320)	(480)	-	cd/m ²	
Luminance Uniformity		YU		70	80	-	%	Note 5

Note 1 : Definition of Contrast Ratio (CR) :

The contrast ratio can be calculated by the following expression.

$$\text{Contrast Ratio (CR)} = L_{63}/L_0$$

L63 : Luminance of gray level 63

L0 : Luminance of gray level 0

$$CR = CR(5)$$

CR(X) is corresponding to the Contrast Ratio of the point X at Figure in Note 5

Note 2 : Definition of Response Time (TR,TF)

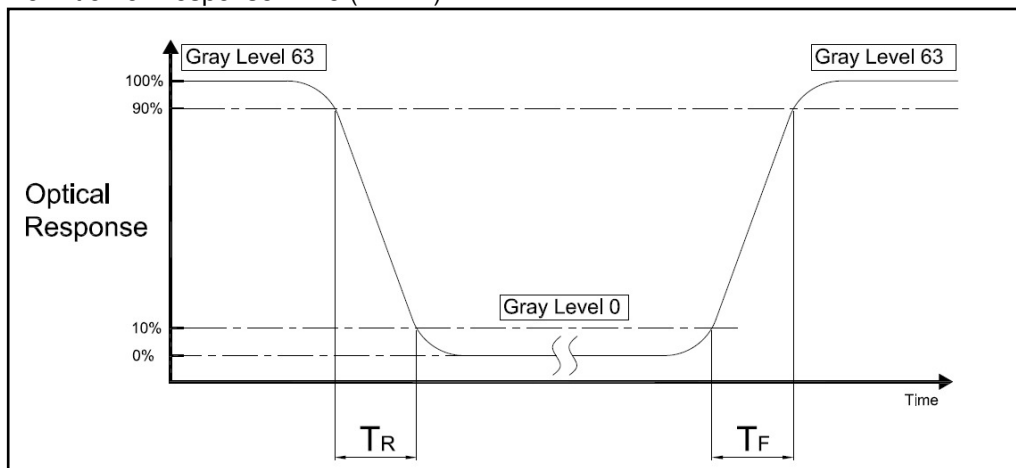

Note 3 : Definition of Viewing Angle

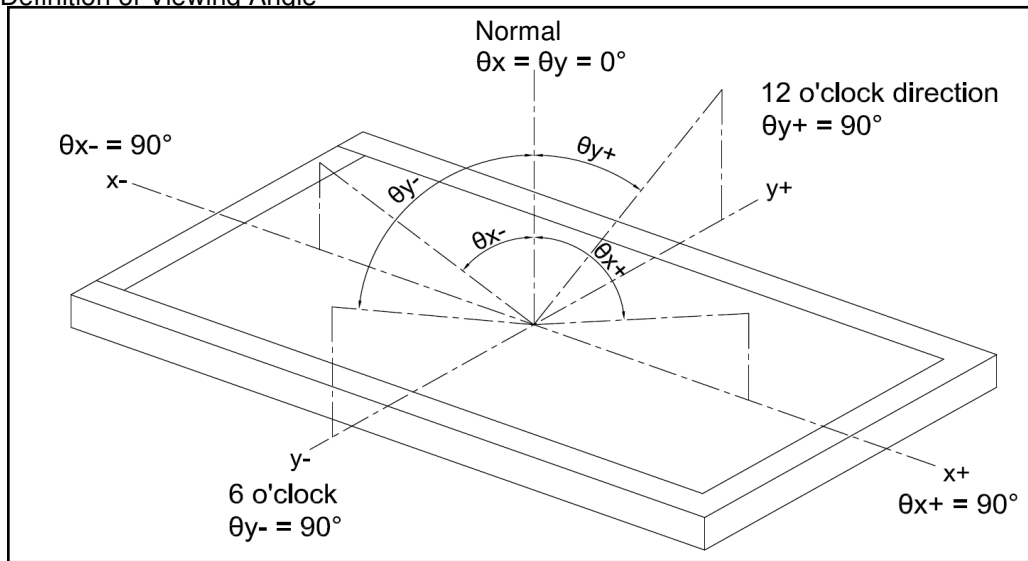

Note 4 : Measurement Set-Up:

The LCD module should be stabilized at a given temperature for 20 minutes to avoid abrupt temperature change during measuring. In order stabilize the luminance, the measurement should be executed after lighting Backlight for 20 minutes in a windless room.

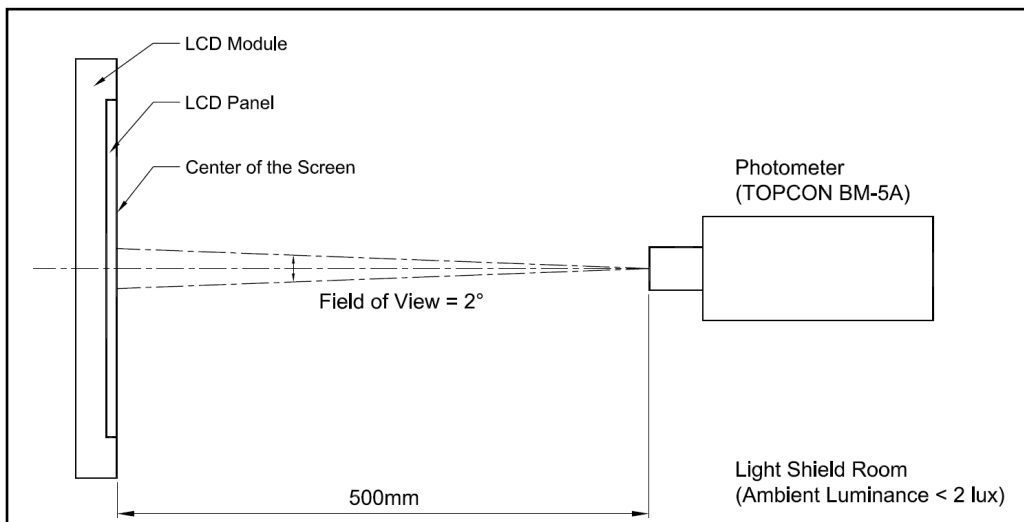

Note 5 :

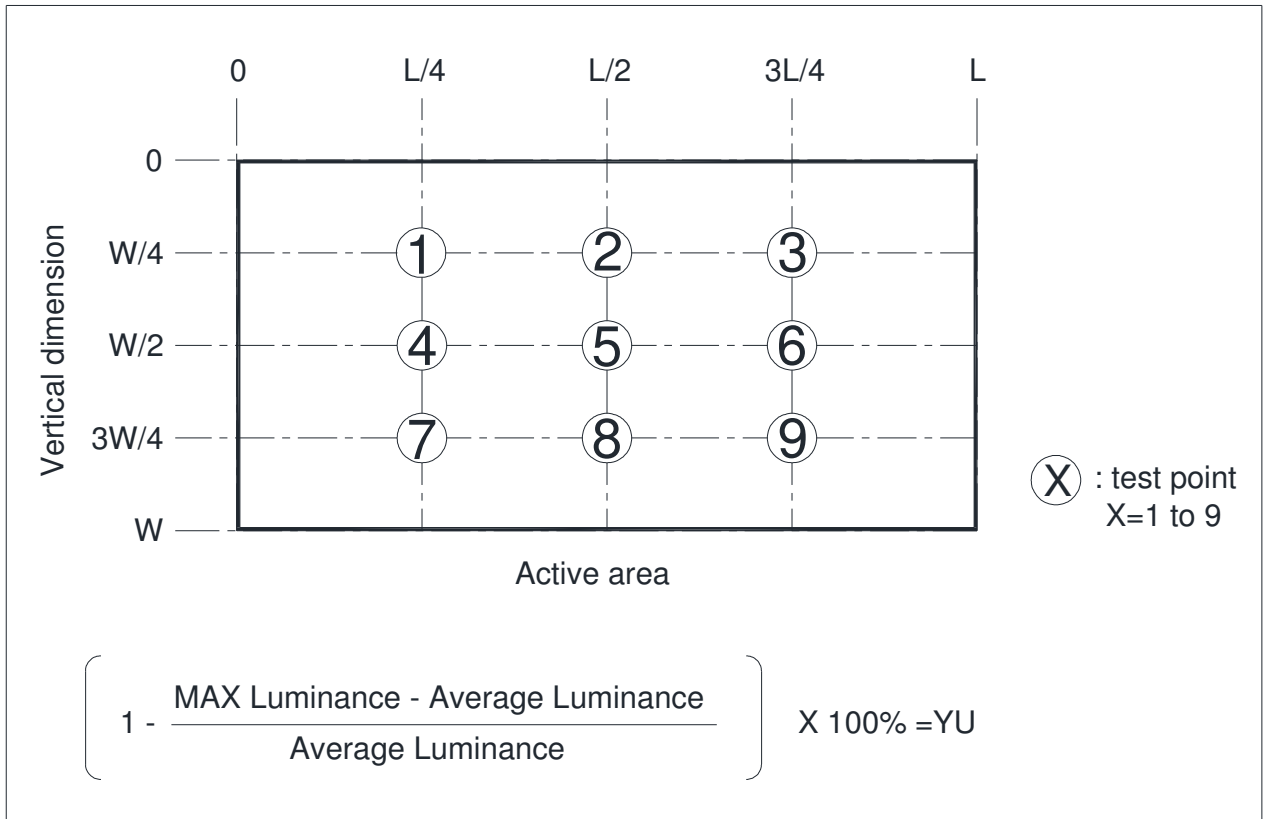

9. TOUCH PANEL SPECIFICATIONS

9.1 Type :

Projected capacitive Touch Panel
Input Mode : Finger available

9.2 STRUCTURE :

Cover Glass 1.1mm, Glass Sensor 0.7mm

9.3 IC MODEL :

9.3.1 IC ILI2511
9.3.2 IC on FPC
9.3.3 Interface : USB

9.4 ELECTRICAL CHARACTERISTICS :

9.4.1 The Max rated Voltage : 5V

9.5 MECHANICAL CHARACTERISTICS :

9.5.1 Input Mode : Finger
9.5.2 Surface hardness : 6H
Decoration Film : PE Protective Film

9.6 OPTICAL CHARACTERISTICS :

9.6.1 Transparency : 85%(Min.)

10. TIMING SPECIFICATIONS

10.1.1 POWER ON

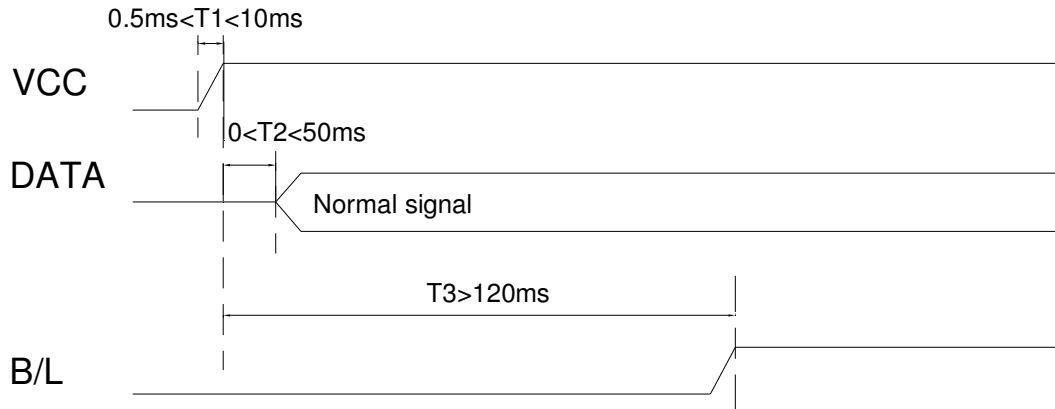

10.1.2 POWER OFF

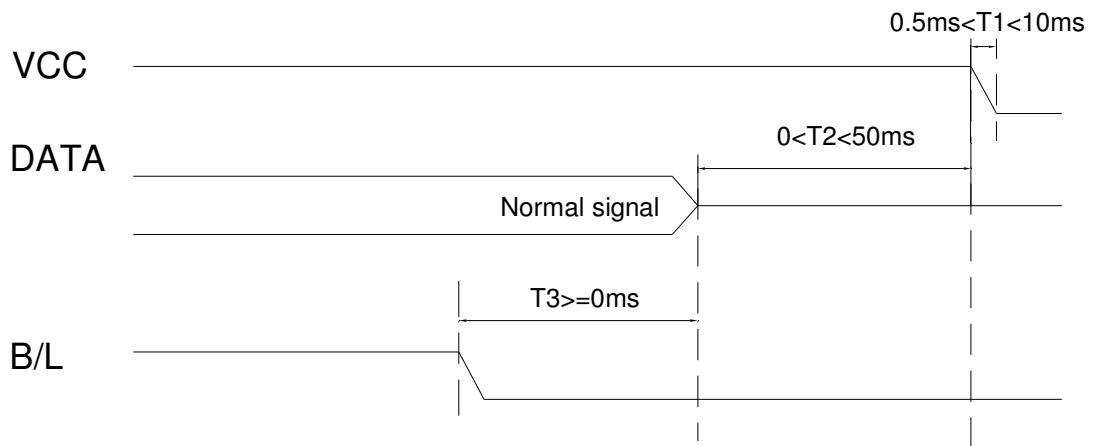

10.2 RESET TIMING CHARACTERISTICS

AC Electrical Characteristics

PARAMETER	SYMBOL	MIN	TYP	MAX	UNIT	REMARK
LVDS Differential input high Threshold voltage	RxVTH	-	-	+100	mV	Rxvcm=1.2V
LVDS Differential input low Threshold voltage	RxVTL	-100	-	-	mV	
LVDS Differential input common mode voltage	RxVCM	0.7	-	1.6	V	
LVDS Differential input	VID	200	-	600	mV	

Single-end signals

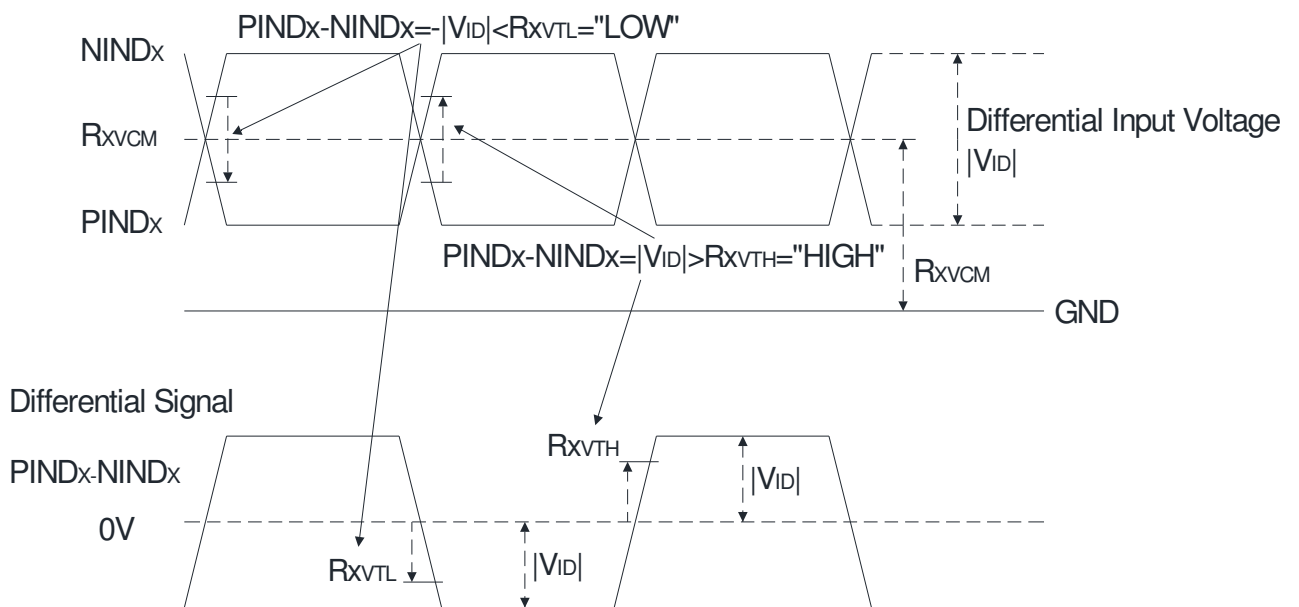

10.3 Timing

PARAMETER	SYMBOL	MIN	TYP	MAX	UNIT	REMARK
Clock Frequency	1/Tc	68.9	71.1	73.4	MHz	Frame rate=60Hz
Horizontal display area	thd	1280			Tc	
HS period time	th	1410	1440	1470	Tc	
HS Width+Back Porch+Front Porch	thw+thbp+thfp	130	160	190	Tc	
Vertical display area	tvd	800			tH	
VS period time	tv	815	823	833	tH	
VS Width+Back Porch+Front Porch	tvw+tvbp+tvfp	15	23	33	tH	

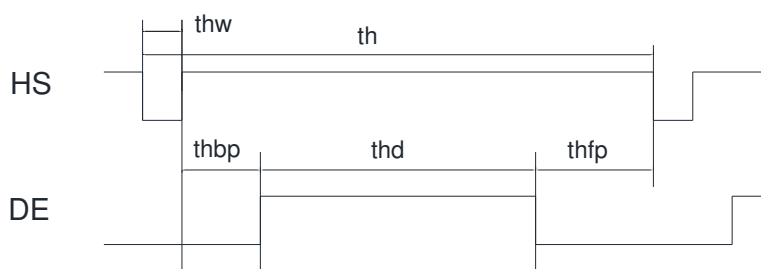
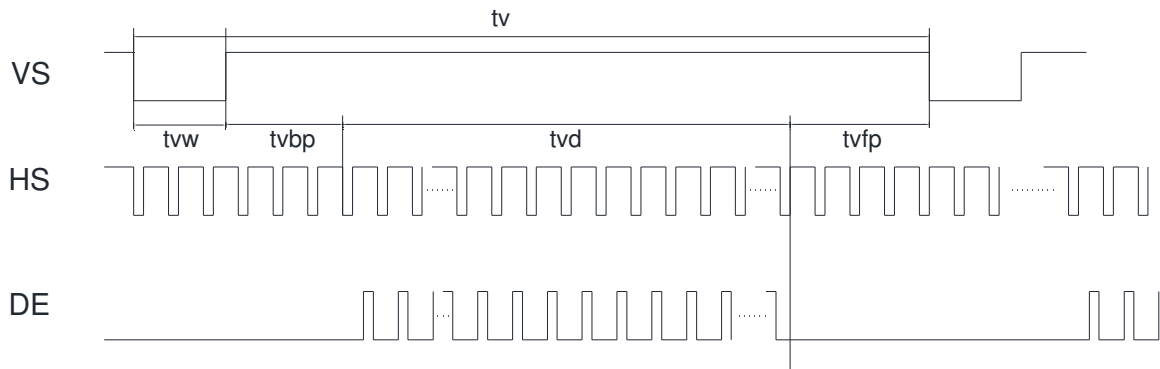

10.4 Data Input format

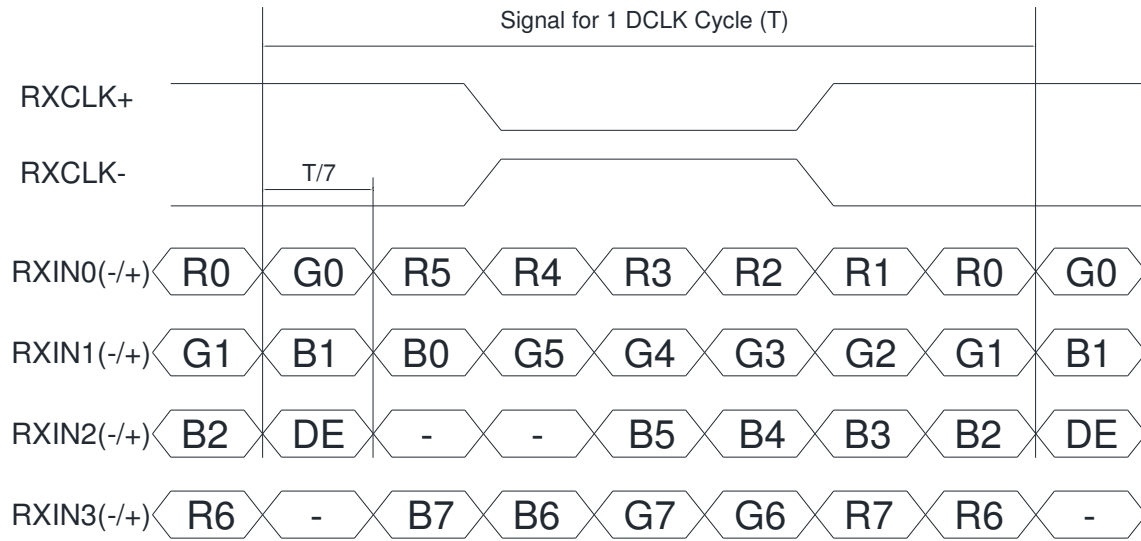

11. RELIABILITY TEST

ENVIRONMENTAL TEST				
NO.	ITEM	CONDITIONS	TIME PERIOD	REMARK
1	High Temperature Storage	80°C	240Hours	Note 1,4
2	Low Temperature Storage	-30°C	240Hours	Note 1,4
3	High Temperature Humidity Storage	40°C,90%RH	240Hours	Note 4
4	High Temperature Operation	70°C	240Hours	Note 2,4
5	Low Temperature Operation	-20°C	240Hours	Note1,4
6	Temperature Cycle	-30°C ~ 80°C (30min) (30min)	100CYCLE	Note 4

Note1 : Ta is the ambient temperature of samples.

Note2 : Ts is the temperature of panel's surface.

Note3 : In the standard condition, there shall be no practical problem that may affect the display function. After the reliability test, the product only guarantees operation, but don't guarantee all of the cosmetic specification.

Note4 : Before cosmetic and function test, the product must have enough recovery time, at least 2 hours at room temperature.

12. LCM INSPECTION STANDARD

Inspection specifications refer ONation Corporation LCM INSPECTION STANDARD Document.
Document Number : TBD

13. PACKAGE INFORMATION

LCM Model	LCM Qty. in the box	Inner Box Size (mm)	Weight	REMARK
OT101CBWDLT-05	TBD	TBD	TBD	

14.PRECAUTIONS FOR USE

14.1 SAFETY

- (1) Do not swallow any liquid crystal, even if there is no proof that liquid crystal is poisonous.
- (2) If the LCD panel breaks, be careful not to get liquid crystal to touch your skin.
- (3) If skin is exposed to liquid crystal, wash the area thoroughly with alcohol or soap.

14.2 STORAGE CONDITIONS

- (1) Store the panel or module in a dark place where the temperature is $23\pm 5^{\circ}\text{C}$ and the humidity is below $50\pm 20\% \text{RH}$.
- (2) Store in anti-static electricity container.
- (3) Store in clean environment, free from dust, active gas, and solvent.
- (4) Do not place the module near organics solvents or corrosive gases.
- (5) Do not crush, shake, or jolt the module.

14.3 HANDLING PRECAUTIONS

- (1) Avoid static electricity which can damage the CMOS LSI.
- (2) The polarizing plate of the display is very fragile. So, please handle it very carefully.
- (3) Do not give external shock.
- (4) Do not apply excessive force on the surface.
- (5) Do not wipe the polarizing plate with a dry cloth, as it may easily scratch the Surface of plate.
- (6) Do not use ketonics solvent & Aromatic solvent, use with a soft cloth soaked with a cleaning naphtha solvent.
- (7) Do not operate it above the absolute maximum rating.
- (8) Do not remove the panel or frame from the module.
- (9) When the module is assembled, it should be attached to the system firmly, Be careful not to twist and bend the module.
- (10) Wipe off water droplets or oil immediately . If you leave the droplets for a long time, staining and discoloration may occur.
- (11) If the liquid crystal material leaks from the panel, it should be kept away from the eyes or mouth. In case of contact with hands, legs or clothes, it must be washed away thoroughly with soap.

14.4 WARRANTY

- (1) Acceptance inspection period
The period is within one month after the arrival of contracted commodity at the buyer's factory site.
- (2) Applicable warrant period
The period is within 12 months since the date of shipping out under normal using and storage conditions.