

# TFT-DISPLAY DATASHEET

ONation  
Model: OT150CXDDLV-H1

## BRIEF SPEC.:

Main Feature	Landscape Type White LED Backlight
Active Screen Area	304.12 x 228.09 (mm)
Diagonal   Format	15"   4:3
Resolution	1024 x 768
Colors	R.G.B Stripe
Backlight	LED, White
Brightness	1000 cd/m <sup>2</sup>
LED Life Time	50,000h (Typ.)
Interface	LVDS
Viewing Angle	-70~80(H), -50~70(V)
Touchscreen	No
Power Supply	3,3V (Typ.)
Module Outline	326.5 x 253.5 x 15.66 (mm)
Operation Temperature	-30... +85 °C
Storage Temperature	-30... +85 °C
Surface Treatment	Anti-Glare



# ONation Corporation

## TFT COLOR LCD MODULE

**MODEL: OT150CXDDL V-H1**  
(Complied with RoHS)

**XGA**  
**LVDS interface (1port)**

**Version: P0.1**

<b>Customer :</b> _____
<b>Approved By :</b> _____
<b>Date:</b> _____

ONATION		
APPROVAL	CHECKER	PREPARE
<i>Jan</i>	<i>Josh</i>	<i>Jan</i>

All information is subject to change without notice.  
Please confirm the sales representative before starting to design your system

## C O N T E N T S

NO.	ITEM	PAGE
1	RECORD OF REVISION	0-1
2	MECHANICAL SPECIFICATIONS	1
3	OUTLINE DIMENSIONS	2
4	INTERFACE PIN CONNECTION	3
5	BLOCK DIAGRAM	4
6	ABSOLUTE MAXIMUM RATINGS	5
7	ELECTRICAL CHARACTERISTICS	6 ~ 7
8	OPTICAL CHARACTERISTICS	8 ~ 10
9	TIMING SPECIFICATIONS	11 ~ 13
10	RELIABILITY TEST	14 ~ 15
11	LCM INSPECTION STANDARD	16
12	PACKAGE INFORMATION	16
13	PRECAUTIONS FOR USE	17

**1.RECORD OF REVISION**

REV	DATE	PAGE	SUMMARY
0.1	2016.03.16	ALL	Preliminary specification was first issued.

## 2.MECHANICAL SPECIFICATIONS

(1)	Number Of Dots (Dots)	1024(R.G.B) X 768
(2)	Module Size(mm)	326.5(H) X 253.5(V) X 15.66(D) **
(3)	Active Area(mm)	304.128(H) X 228.096(V)
(4)	Pixel Pitch(mm)	0.297(H) X 0.297(V)
(5)	LCD / Polarizer Model	TFT , Transmissive, Normally/White, Anti-Glare
(6)	Backlight Color	White, LED
(7)	Viewing Direction	12 O'clock Horizontal : Right side 80°(typ.), Left side 80°(typ.) Vertical : Up side 70°(typ.), Down side 80°(typ.)
(8)	Gray Scale Inversion Direction	6 O'clock
(9)	Electrical Interface	LVDS Interface
(10)	Color Configuration	R.G.B Stripe
(11)	Support Color	16.2M / 262K
(12)	Module Weight(g)	(1100±5%)

\*\* Include connector thickness

### 3. OUTLINE DIMENSION

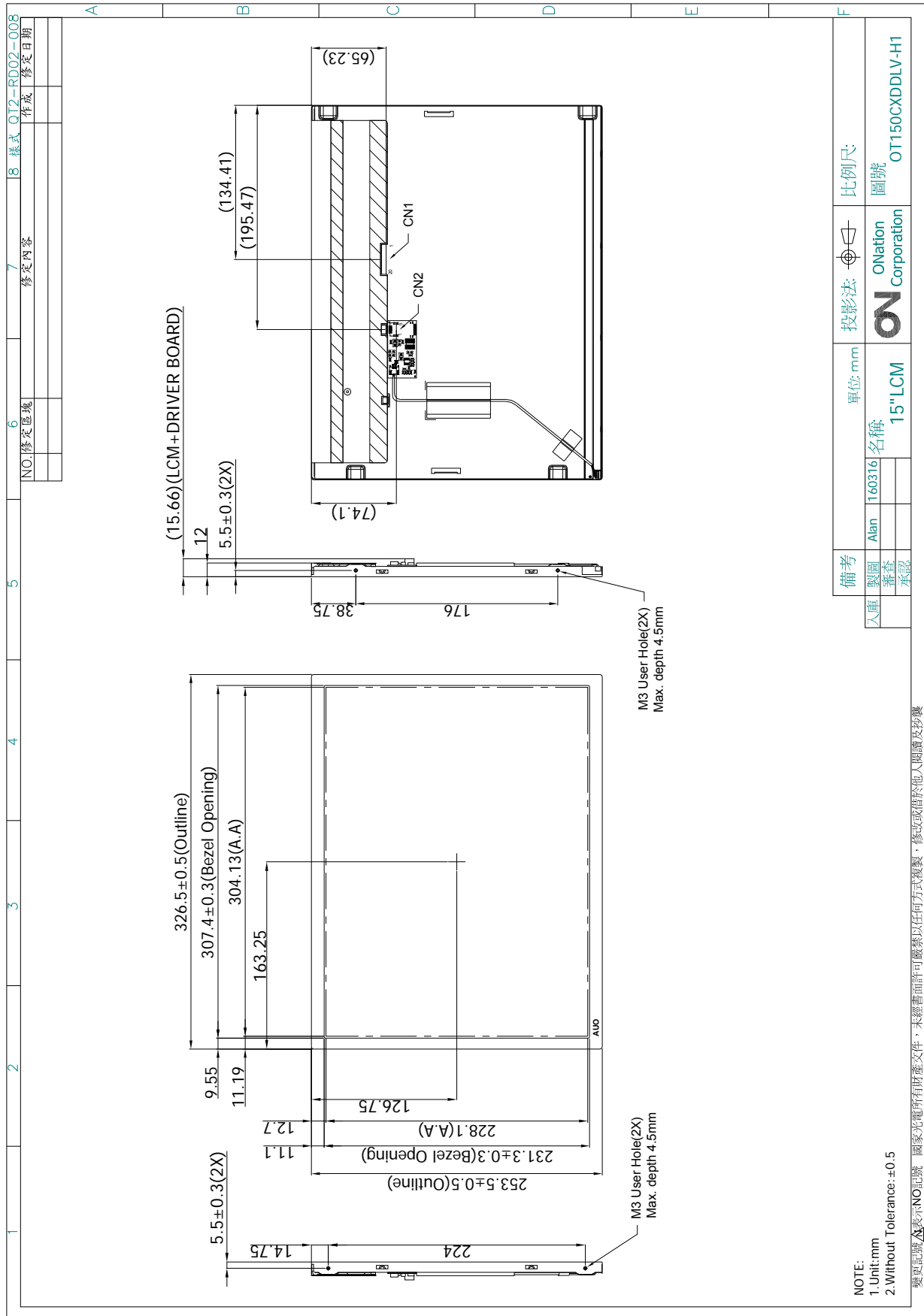

## 4. INTERFACE PIN CONNECTION

### 4.1 LCM PANEL DRIVING SECTION

CN1 Connector : STM MSB240420E or Equivalen

Mating Connector : STM P240420 or Equivalent

PIN NO.	SIGNAL	FUNCTION	REMARK
1	VDD	Power Supply, 3.3V (typical)	
2	VDD	Power Supply, 3.3V (typical)	
3	NC	Not connect	
4	NC	Not connect	
5	RxIN0-	-LVDS differential data input	
6	RxIN0+	+LVDS differential data input	
7	GND	Ground	
8	RxIN1-	-LVDS differential data input	
9	RxIN1+	+LVDS differential data input	
10	GND	Ground	
11	RxIN2-	-LVDS differential data input	
12	RxIN2+	+LVDS differential data input	
13	GND	Ground	
14	CLKIN-	-LVDS differential clock input	
15	CLKIN+	+LVDS differential clock input	
16	GND	Ground	
17	RxIN3-	-LVDS differential data input	
18	RxIN3+	+LVDS differential data input	
19	GND	Ground	
20	SEL	LVDS 6/8 bit select function control, High or NC : 6bit Input Mode ; Low : 8bit Input Mode	

### 4.2 BACKLIGHT DRIVING SECTION

CN2 Connector : STM MSA24038P5 or Equivalen

Mating Connector : STM P24038P5 or Equivalent

PIN NO.	SIGNAL	FUNCTION	REMARK
1	VLED	Power Supply : +12V	
2	VLED	Power Supply : +12V	
3	VSS	Ground	
4	VSS	Ground	
5	ADJ	Adjust Brightness Control For LED B/L	

### 5. BLOCK DIAGRAM

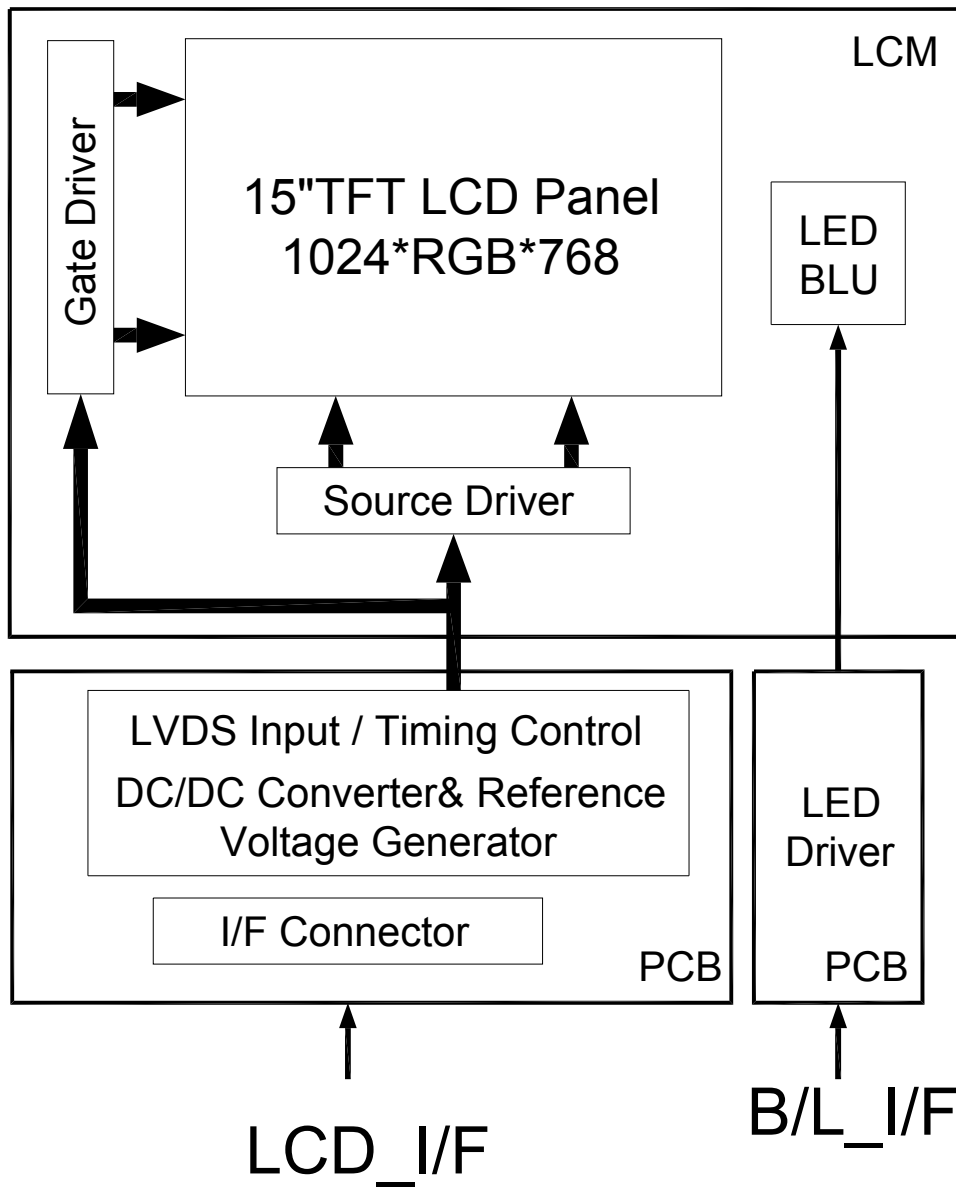



## 6. ABSOLUTE MAXIMUM RATINGS

### 6.1 ELECTRICAL ABSOLUTE MAXIMUM RATINGS

ITEM	SYMBOL	MIN.	MAX.	UNIT	REMARK
Supply Voltage	VDD	-0.5	+3.6	V	
	VLED	-0.5	+36	V	

Note: The absolute maximum rating values of this product not allowed to be exceeded at any times. Should be module be used with any of absolute maximum ratings exceeded. The characteristics of the module may not be recovered, or in an extreme case, the module may be permanently destroyed.

### 6.2 ENVIRONMENTAL ABSOLUTE MAXIMUM RATINGS

ITEM	OPERATING		STORAGE		REMARK
	MIN.	MAX.	MIN.	MAX.	
Ambient Temperature(°C)	-30	85	-30	85	Note 1,2
Humidity(% RH)	8 ~ 90		8 ~ 90		Note 3

Note 1 : The response time will become lower when operated at low temperature.

Note 2 : Background color changes slightly depending on ambient temperature.

Note 3 : Storage Ta=50°C & RH=80% ≤ 240Hrs.

## 7. ELECTRICAL CHARACTERISTICS

### 7.1 ELECTRICAL CHARACTERISTICS OF LCD

Ta=25°C

ITEM	SYMBOL	MIN.	TYP.	MAX.	UNIT	REMARK
Logic/LCD Drive Voltage	VDD	3.0	3.3	3.6	V	
VDD Current	IDD	-	(450)	(750)	mA	Note 1
LCD Inrush Current	Irush					
VDD Power	PDD	-	-	200	[mV]p-p	

Note 1 : Test condition : VDD=3.3V ; Test Pattern : Black.

Note 2: Measure Condition

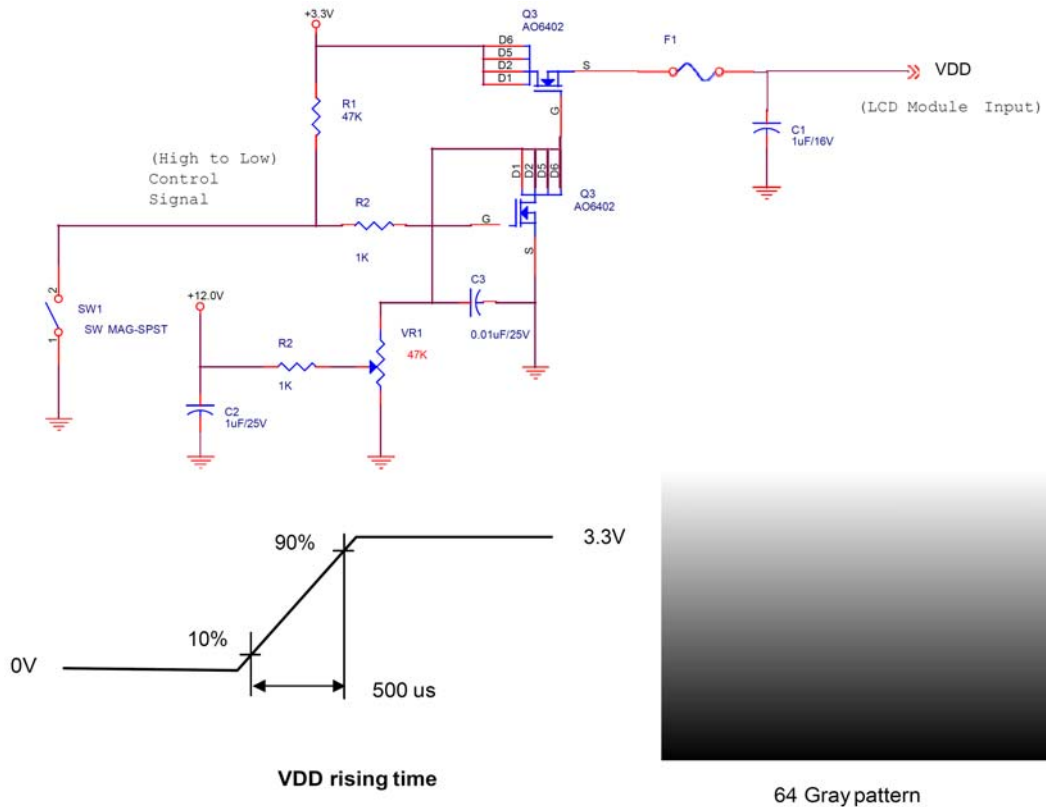

## 7.2 BACKLIGHT UNITS

Ta=25°C

ITEM		SYMBOL	MIN.	TYP.	MAX.	UNIT
LED Driving Voltage		VLED	9	12	15	V
		ILED (VLED=12V)	-	TBD	TBD	mA
PWM Control Level	PWM High Level	-	3.0	3.3	3.6	V
	PWM Low Level	-	0	-	1.0	V
PWM Control Duty Ratio		-	0	-	100	%
PWM Control Frequency		f <sub>PWM</sub>	100	-	2000	Hz
LED Life Time (For Reference only)		-		50,000		Hr

Note 1: The LED of B/L is drive by current only, drive voltage is for reference only. drive voltage can make driving current under safety area(current between minimum and maximum). 50,000 hours is only an estimate for reference.

Note 2: The lifetime of LED is defined as the time when it continues to operate under the conditions at Ta= 25 ±2°C and PWM=100% (LED forward current) until the brightness becomes ≤ 50% of its original value.

## 8. OPTICAL CHARACTERISTICS

Ta=25°C

ITEM	SYMBOL	CONDITIONS	MIN.	TYP.	MAX.	UNIT	REMARK
Contrast Ratio	CR	Viewing Normal Angle $\Theta_x = \Theta_y = 0^\circ$	450	800	-	-	Note 1
Response Time	TR+TF		-	8	-	ms	Note 2
Chromaticity	White	x	(0.261)	(0.311)	(0.361)	-	Note 4
		y	(0.272)	(0.322)	(0.372)	-	
Viewing Angle	Hor.	$\theta_{x+}$	70	80	-	Deg.	Note 3
		$\theta_{x-}$	70	80	-		
	Ver.	$\theta_{y+}$	50	70	-		
		$\theta_{y-}$	70	80	-		
Luminance	L	PWM=100%	800	1000	-	cd/m <sup>2</sup>	
Luminance Uniformity	YU	PWM=100%	70	-	-	%	Note 5

Note 1 : Definition of Contrast Ratio (CR) :

The contrast ratio can be calculated by the following expression.

$$\text{Contrast Ratio (CR)} = L_{63}/L_0$$

L63 : Luminance of gray level 63

L0 : Luminance of gray level 0

$$CR = CR(5)$$

CR(X) is corresponding to the Contrast Ratio of the point X at Figure in Note 5

Note 2 : Definition of Response Time (TR,TF)

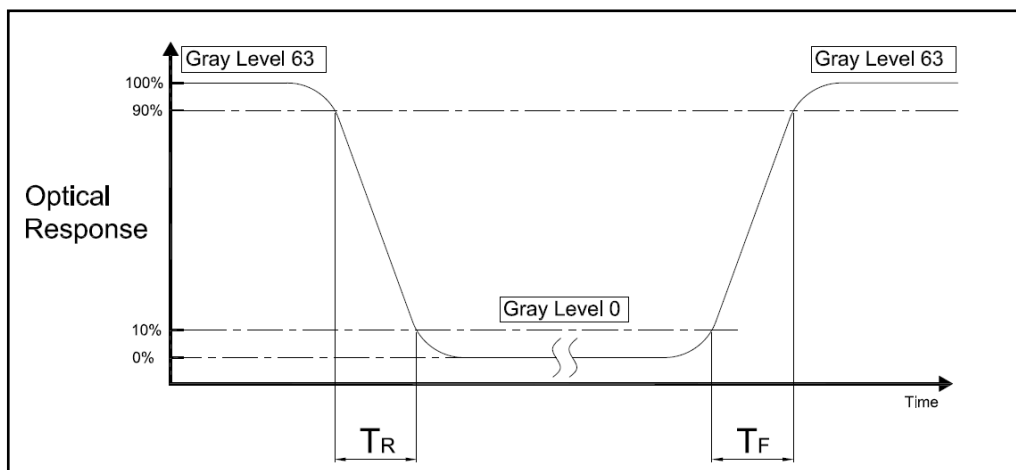

Note 3 : Definition of Viewing Angle

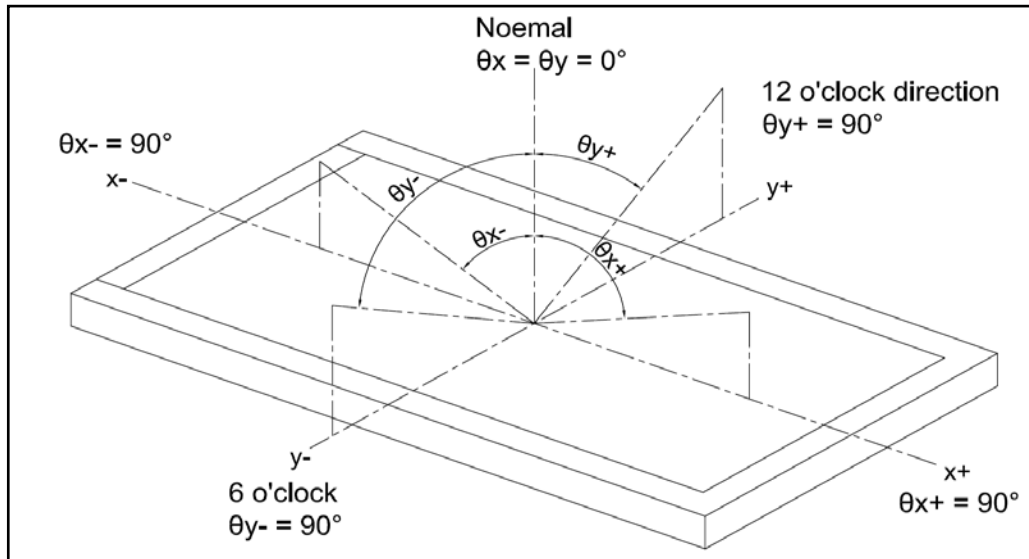

Note 4 : Measurement Set-Up:

The LCD module should be stabilized at a given temperature for 20 minutes to avoid abrupt temperature change during measuring. In order stabilize the luminance, the measurement should be executed after lighting Backlight for 20 minutes in a windless room.

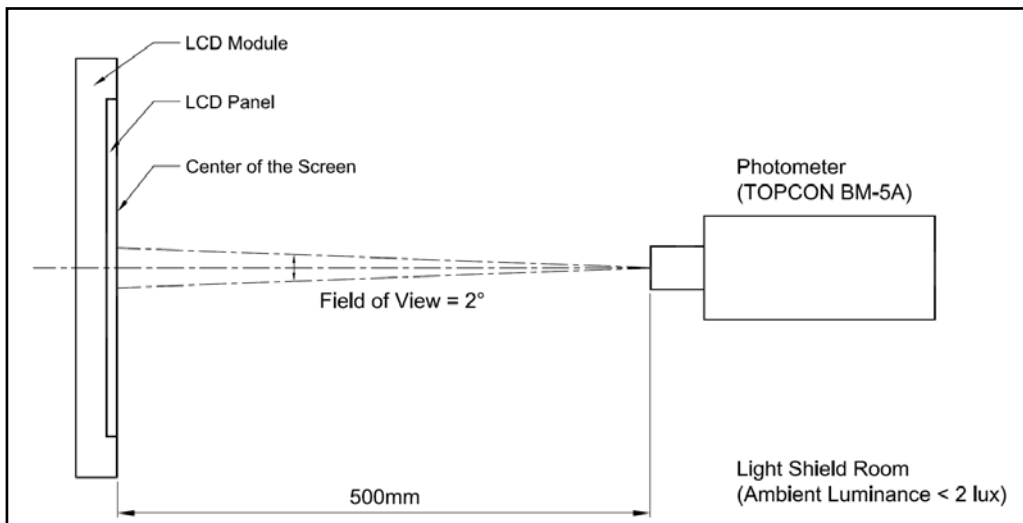

Note 5 :

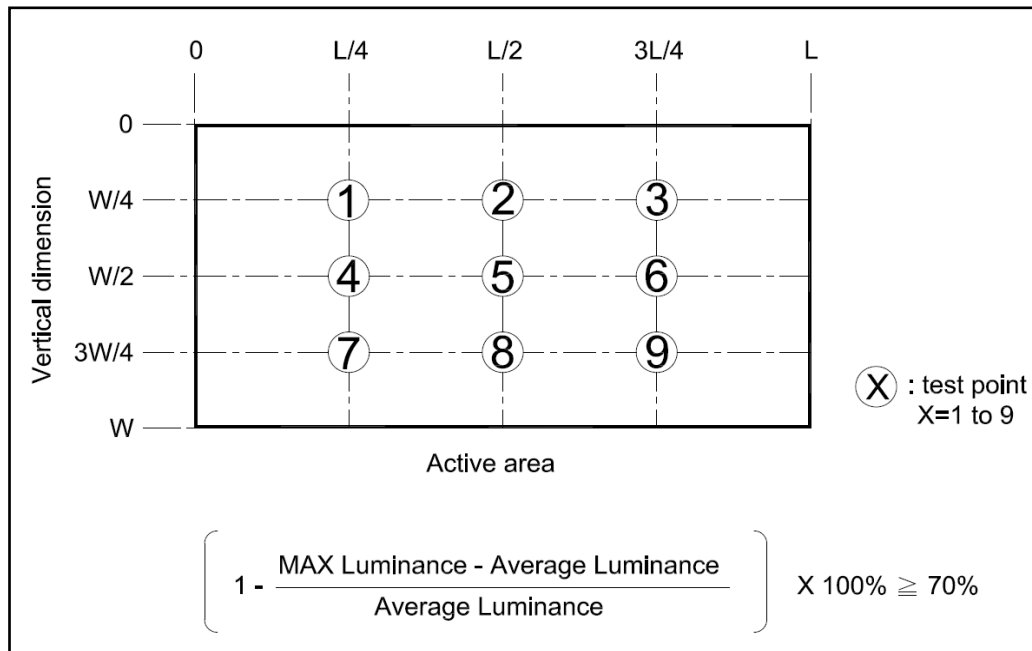

## 9. TIMING SPECIFICATIONS

### 9.1 POWER SIGNAL SEQUENCE

VDD power on/off sequence is as follows. Interface signals are also shown in the chart. Signals from any system shall be Hi-Z state or low level when VDD is off. a. Power on sequence:

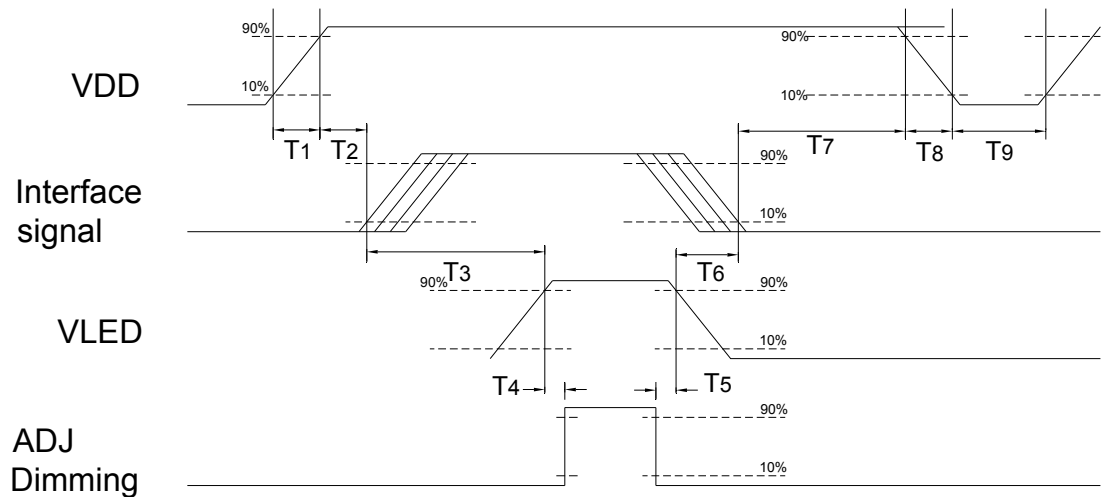

Power ON/OFF sequence timing

ITEM	MIN.	TYP.	MAX.	UNIT
T1	0.5	-	10	ms
T2	30	40	50	ms
T3	200	-	-	ms
T4	20	-	-	ms
T5	10	-	-	ms
T6	100	-	-	ms
T7	-	16	60	ms
T8	-	-	10	ms
T9	1000	-	-	ms

The above on/off sequence should be applied to avoid abnormal function in the display. Please make sure to turn off the power when you plug the cable into the input connector or pull the cable out of the connector.

## 9.2 INTERFACE TIMING

### 9.2.1 Timing Characteristics

Synchronization Method : DE only

ITEM		SYMBOL	MIN.	TYP.	MAX.	UNIT	
Clock Timing	Clock frequency		1/ TClock	50	65	80	MHz
	Vsync Timing	Vertical Section	Period	TV	776	806	990
Active			TVD	-	768	-	
Blanking			TVB	8	38	222	
Hsync Timing	Horizontal Section	Period	TH	1094	1344	1720	Hsync Timing
		Active	THD	-	1024	-	
		Blanking	THB	70	320	696	
Frame Rate			F	50	60	75	Hz

Note: DE mode only.

Note : Typical value refer to VESA STANDARD

### 9.2.2 Input Timing Diagram

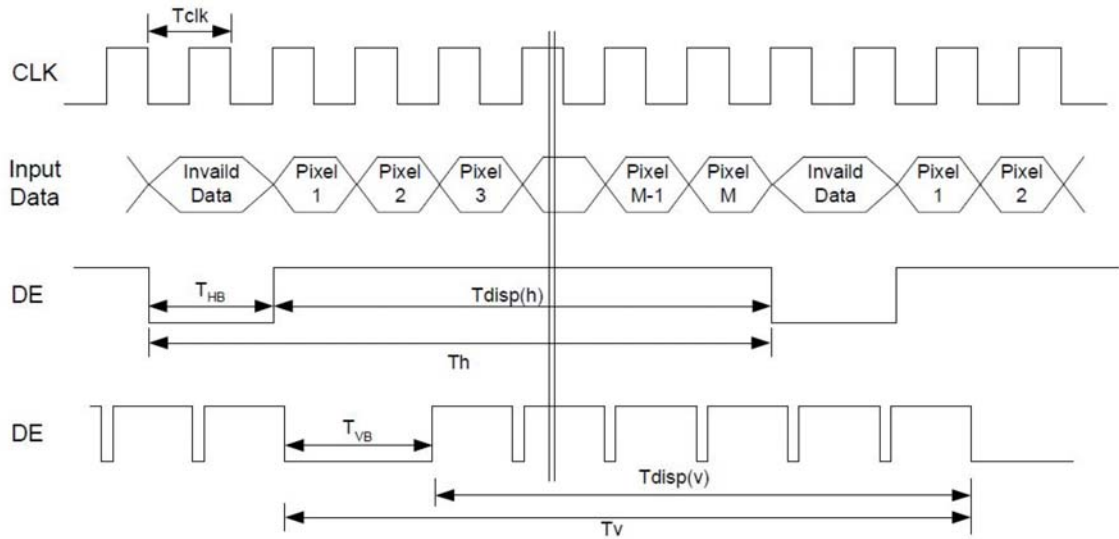



9.2.3 The Input Data Format

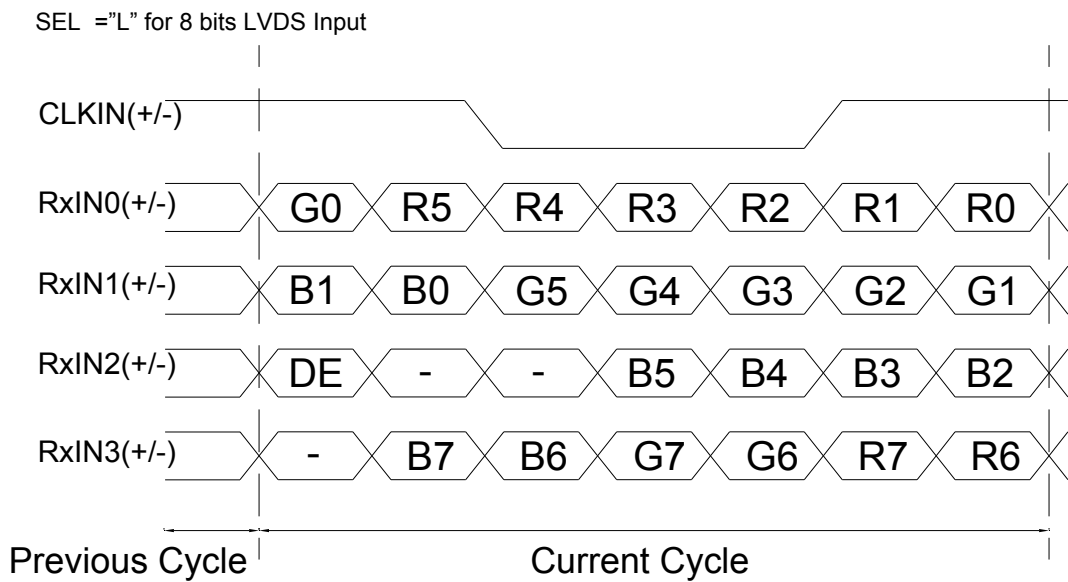
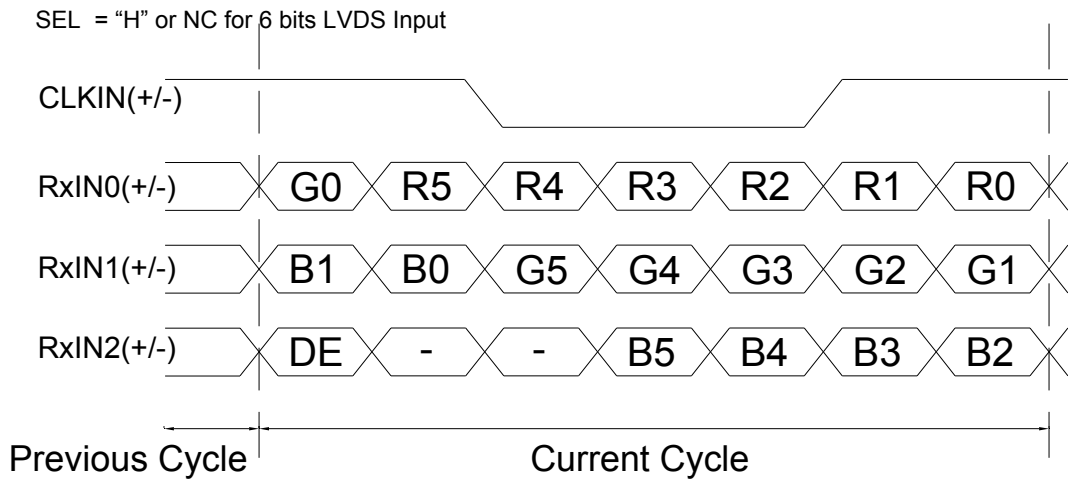

Note1: Please follow PSWG.  
 Note2: R/G/B data 7:MSB, R/G/B data 0:LSB

## 10. RELIABILITY TEST

ENVIRONMENTAL TEST				
NO.	ITEM	CONDITIONS	TIME PERIOD	REMARK
1	High Temperature Storage	85°C	240HRS	
2	Low Temperature Storage	-30±3°C	240HRS	
3	High Temperature Operation	85°C	240HRS	
4	Low Temperature Operation	-30°C	240HRS	
5	Temperature Cycle	-20°C ← 25°C → 60°C (30min) (5min) (30min)	100CYCLE	
6	High Temperature Humidity Storage	50°C 80%RH (No condensation)	240HRS	

Note 1: a. The module should work properly.  
 b. Before and after function test, The difference of consumptive current. Should be within 10%

Note 2: a. The module should work properly.  
 b. The modlue won't be deformative, Color changeable or broken.  
 c. The modules can't be apart.

Note 3: a. Before cosmetic and function test, The product must have enough recovery time, At least 2 hours at room temperature.

## 10.1 VIBRATION TEST :

### 10.1.1 STATE LABORATORY ENVIRONMENT :

Room temperature :  $25\pm 3^{\circ}\text{C}$   
Relative humidity :  $55\pm 20\% \text{RH}$

### 10.1.2 TEST METHOD / SPECIFICATION :

Sample Status : Non-packaged single state  
Waveform : Sine  
Frequency : 10~55~10Hz  
Full amplitude : 1.5mm  
Vibration direction : X,Y,Z Axis (3 Axial)  
Test time : Each 2Hour / X,Y,Z Axis , Altogether 6 Hour

## 10.2 MECHANICAL SHOCK TEST :

### 10.2.1 STATE LABORATORY ENVIRONMENT :

Room temperature :  $25\pm 3^{\circ}\text{C}$   
Relative humidity :  $55\pm 20\% \text{RH}$

### 10.2.2 TEST METHOD / SPECIFICATION :

Sample Status : Non-packaged single state  
Waveform : Half-sine  
Acceleration : 10G  
Shock Time : 20ms  
Impact direction : 6 Directions ( $\pm X, \pm Y, \pm Z$  axes)  
Number of shocks : Each direction 3 Secondary , Altogether 18 Secondary

## 11. LCM INSPECTION STANDARD

Inspection specifications refer ONation Corporation LCM INSPECTION STANDARD Document.  
Document Number : TBD

## 12. PACKAGE INFORMATION

LCM Model	LCM Qty. in the box	Inner Box Size (mm)	Weight	REMARK
OT150CXDDLV-H1	TBD	TBD	TBD	

## 13. PRECAUTIONS FOR USE

### 13.1 SAFETY

- (1) Do not swallow any liquid crystal, even if there is no proof that liquid crystal is poisonous.
- (2) If the LCD panel breaks, be careful not to get liquid crystal to touch your skin.
- (3) If skin is exposed to liquid crystal, wash the area thoroughly with alcohol or soap.

### 13.2 STORAGE CONDITIONS

- (1) Store the panel or module in a dark place where the temperature is  $23\pm 5^{\circ}\text{C}$  and the humidity is below  $50\pm 20\%\text{RH}$ .
- (2) Store in anti-static electricity container.
- (3) Store in clean environment, free from dust, active gas, and solvent.
- (4) Do not place the module near organics solvents or corrosive gases.
- (5) Do not crush, shake, or jolt the module.

### 13.3 HANDLING PRECAUTIONS

- (1) Avoid static electricity which can damage the CMOS LSI.
- (2) The polarizing plate of the display is very fragile. So, please handle it very carefully.
- (3) Do not give external shock.
- (4) Do not apply excessive force on the surface.
- (5) Do not wipe the polarizing plate with a dry cloth, as it may easily scratch the Surface of plate.
- (6) Do not use ketonics solvent & Aromatic solvent, use with a soft cloth soaked with a cleaning naphtha solvent.
- (7) Do not operate it above the absolute maximum rating.
- (8) Do not remove the panel or frame from the module.
- (9) When the module is assembled, it should be attached to the system firmly, Be careful not to twist and bend the module.
- (10) Wipe off water droplets or oil immediately . If you leave the droplets for a long time, staining and discoloration may occur.
- (11) If the liquid crystal material leaks from the panel, it should be kept away from the eyes or mouth. In case of contact with hands, legs or clothes, it must be washed away thoroughly with soap.

### 13.4 WARRANTY

- (1) Acceptance inspection period  
The period is within one month after the arrival of contracted commodity at the buyer's factory site.
- (2) Applicable warrant period  
The period is within 12 months since the date of shipping out under normal using and storage conditions.